

Titan Mobile

Operator's Manual

Version 5.0



Installation CD inside



Copyright Avolites 2011

Useful Avolites phone numbers: -

Avolites England

Sales and service* (+44) (0) 20 8965 8522

Service out of hours* (+44) (0) 831 17 8888

Fax (+44) (0) 20 8965 0290

Email support@avolites.com

Website <http://www.avolites.com>

Before contacting Avolites for service enquiry please ensure that you have the product serial number and the Software version. The serial number can be found on the back of the desk; the software version is displayed on the menu prompt when Titan Mobile is switched to System mode.

The latest version of this manual and console Software can be downloaded from the Avolites website.

The small print :

No Liability for Consequential Damages

Avolites has a policy of continuous product and documentation improvement. As such the detail within this manual may not match the operation of the console.

In no event shall Avolites be liable for any direct, indirect, special, incidental, or consequential damages or loss whatsoever (including, without limitation, damages for loss of profits, business interruption, or other pecuniary loss) arising out of the use or inability to use the console even if Avolites Ltd. has been advised of the possibility of such damages. Because some jurisdictions do not allow the exclusion or limitation of liability for consequential or incidental damages, the above limitation may not apply to you.

Avolites Ltd recognise that all trademarks within the manual are the property of their respective owners.

Reprint and revision history:

Titan Universal Manual v5: Aug 2011

Copyright Avolites 2011

This manual was written by Tim Mitchell, Sabre Technology Ltd
<http://www.sabretechnology.co.uk>

SECTIONS

1. QUICK START	13
2. SETTING UP AND USING THE CONSOLE	17
3. PATCHING	33
4. CONTROLLING DIMMERS AND FIXTURES	45
5. PALETTES	65
6. SHAPES AND PIXEL MAPPER EFFECTS	75
7. CUES	105
8. CHASES	119
9. CUE LISTS	129
10. RUNNING THE SHOW	143
11. REMOTE CONTROL	149
12. USER SETTINGS AND OTHER OPTIONS	155
13. WORKING WITH FIXTURE PERSONALITIES	169
14. NETWORKING THE CONSOLE	173
15. USING DIFFERENT AVOLITES CONSOLES	183
16. RELEASE NOTES	187
17. GLOSSARY OF TERMS	195



This icon shows important information which you should know about to avoid damage to your console or loss of important data.



This icon shows information which is useful to know.



This icon shows handy tips which will help you use the console more efficiently.

Copyright Avolites 2011

CONTENTS

1.	Quick Start	13
1.1	Patching fixtures	13
1.2	Controlling fixtures	13
1.3	Programming cues and chases.....	14
1.4	Programming palettes	14
1.5	DMX / network setup	15
2.	Setting up and using the console	17
2.1	Guide to Titan Mobile	17
2.2	Connecting up.....	20
2.2.1	Cautions	20
2.2.2	Software installation.....	20
2.2.3	Connecting to your laptop/PC	20
2.2.4	Connecting DMX lines	20
2.3	Using the on-screen workspace	21
2.3.1	Workspace windows	21
2.3.2	The menu area of the touch screen	23
2.3.3	The Heads-Up Display (HUD).....	25
2.3.4	Visualiser	26
2.3.5	Key profiles.....	26
2.3.6	Undo/Redo.....	27
2.3.7	Key macro buttons.....	27
2.3.8	Keyboard shortcuts	27
2.3.9	Locking the console.....	29
2.4	Titan Simulator	29
2.4.1	Installing Titan Simulator	29
2.4.2	Running Titan Simulator	30
2.5	Loading and saving shows	30
2.5.1	Manual save and load	30
2.5.2	Autosave	31
2.5.3	Backing up existing show files to USB pen drive.....	31
2.6	Clearing the console.....	31
3.	Patching	33
3.1	Patching new fixtures or dimmers	33
3.1.1	Fixture select buttons and handles	33
3.1.2	Patching dimmers	34
3.1.3	Patching moving light fixtures.....	35
3.1.4	Visualiser Auto Patch.....	37
3.1.5	Sub fixtures	37
3.2	Changing the patch.....	37
3.2.1	Changing the DMX address of a fixture	37
3.2.2	Setting legends.....	38
3.2.3	View Fixture Patch	38
3.2.4	DMX view window	39
3.2.5	Fixture Exchange	40
3.2.6	Update personalities.....	41
3.3	Copying, moving and deleting fixtures	41
3.3.1	Copying or moving a patched fixture	41
3.3.2	Using copied fixtures	42
3.3.3	Deleting a patched fixture	42
3.4	Advanced options	43
3.4.1	Swap pan and tilt.....	43
3.4.2	Invert attributes	43
3.4.3	Freeze fixtures or attributes	44
3.4.4	Editing the personality	44
4.	Controlling dimmers and fixtures	45
4.1	Using the select buttons and wheels.....	45
4.1.1	Selecting fixtures and dimmers for control	45
4.1.2	Setting fixtures to a start position (Locate).....	46
4.1.3	Clearing selection.....	47
4.1.4	Changing attributes using the wheels	48
4.1.5	Setting attributes using the touch screen	49
4.1.6	Setting attributes from the softkeys	51

4.1.7	Selecting fixtures and dimmers by number (Channel)	52
4.1.8	Selecting using a pattern	53
4.1.9	Selecting fixtures which are in a palette or playback	54
4.1.10	Attribute groups – IPCGBES-FX	54
4.1.11	Using fixture groups	54
4.1.12	Fixture Order and Fixture Layout in groups	56
4.1.13	Stepping through selected fixtures one at a time	57
4.1.14	Highlighting the selected fixture with Prev/Next	57
4.1.15	Flash selected fixtures to full	57
4.1.16	Turn off unselected fixtures	58
4.1.17	Align fixtures	58
4.1.18	Flip	58
4.1.19	Fan mode	58
4.2	Viewing and using numerical values	62
4.2.1	The Channel Grid window	62
4.3	Advanced options	62
4.3.1	The Latch Menu button	62
4.3.2	Lamping fixtures on and off	63
5.	Palettes	65
5.1	Creating palettes	66
5.1.1	Which attributes are stored in palettes	66
5.1.2	Storing a palette	66
5.1.3	Quick record	68
5.1.4	Setting legends for palettes	68
5.2	Recalling palettes	69
5.2.1	Recalling a palette value	69
5.2.2	Palette pages	70
5.2.3	Quick palettes with no fixtures selected	70
5.2.4	Setting palettes to all fixtures in a playback	70
5.3	Editing palettes	70
5.3.1	Viewing and editing the content of palettes	70
5.3.2	Changing the content of palettes	71
5.3.3	Updating palettes used in a playback	71
5.4	Copying, moving and deleting palettes	72
5.4.1	Copying or moving a palette	72
5.4.2	Deleting palettes	72
5.5	Timing palettes	73
5.5.1	Fading a palette	73
5.5.2	Fixture overlap when recalling palettes	73
5.5.3	Master Time for palettes	73
6.	Shapes and Pixel Mapper effects	75
6.1	Creating effects	76
6.1.1	Creating a shape	76
6.1.2	Changing size and speed of a shape	77
6.1.3	Changing the phase of a shape across multiple fixtures	78
6.1.4	Creating pixel mapper effects	79
6.2	Editing running shapes	81
6.2.1	Selecting which shape to edit	81
6.2.2	Editing a shape stored in a cue	81
6.2.3	Changing fixture order in a shape	81
6.2.4	Removing or adding fixtures	82
6.2.5	Reversing a shape	82
6.2.6	Deleting shapes	82
6.3	Advanced options	82
6.3.1	Fading shape size and speed	82
6.4	Pixel mapper examples	83
6.4.1	Randomising effects	83
6.4.2	Randomising effects	86
6.4.3	Creative use of fixture layouts	88
6.4.4	Other Layout Editor tools	92
6.4.5	Playback Order and Priorities	93
6.4.6	Displacement and Layer Properties	97
6.4.7	Spawn and Pre-Spool	100
7.	Cues	105
7.1	Creating a cue	105
7.1.1	How Titan Mobile works when programming	105

7.1.2	Creating a cue	106
7.1.3	Quick Build cues	106
7.1.4	Using shapes in cues	106
7.1.5	Blind mode.....	107
7.2	Using a cue.....	107
7.2.1	HTP and LTP.....	107
7.2.2	Playing back a cue	107
7.2.3	Changing playback pages.....	108
7.2.4	Releasing running playbacks.....	108
7.3	Editing cues	109
7.3.1	Editing a cue by merging	109
7.3.2	Updating stored values and palettes used in a cue	109
7.3.3	Playback and Cue view	110
7.3.4	Using parts of existing cues - the Include function.....	111
7.3.5	Removing attributes from cues using "Off"	111
7.4	Copying, moving, linking and deleting	112
7.4.1	Copying or moving a cue	112
7.4.2	Deleting a cue	113
7.5	Cue timing.....	113
7.5.1	Setting fade times and Overlap for a cue	113
7.5.2	Changing fixture order.....	115
7.5.3	Setting attribute fade times for a cue	116
7.6	Advanced options	117
7.6.1	Release mask	117
7.6.2	Shape size/speed on fader	117
7.6.3	Curve	117
7.6.4	Handle Paging	117
7.6.5	Playback priority	117
7.6.6	Blind mode.....	118
7.6.7	Key Profile	118
8.	Chases	119
8.1	Creating a chase	119
8.1.1	Programming a chase.....	119
8.1.2	Creating a chase with Quick Build	120
8.2	Playback	120
8.2.1	Playing back a chase	120
8.2.2	Connecting a chase for control.....	121
8.2.3	Setting speed and crossfade for a Chase.....	121
8.2.4	Manually controlling the steps of a chase	122
8.2.5	Changing chase direction	122
8.2.6	Jumping to a step	122
8.3	Editing a chase.....	123
8.3.1	Opening a chase for editing	123
8.3.2	Editing a chase using Unfold.....	123
8.4	Copying, moving, linking and deleting	124
8.4.1	Copying or moving a chase	124
8.4.2	Deleting a chase	124
8.4.3	Deleting a step from a chase	124
8.5	Chase timing.....	124
8.5.1	Global timings for chases	124
8.5.2	Individual cue times in chases	126
8.5.3	Setting attribute fade times for a cue in a chase	127
8.6	Advanced options	127
8.6.1	Loop/Stop on Final Cue.....	127
8.6.2	Forwards/backwards/bounce/random	127
8.6.3	Cue linking.....	127
8.6.4	Renumber cues.....	128
9.	Cue Lists	129
9.1	Creating a cue list.....	129
9.1.1	Programming a cue-list.....	129
9.1.2	Changing legends for cues in a cue list	131
9.1.3	Autoloading a playback within a cue list	131
9.1.4	Running a key macro from a cue list.....	132
9.2	Cue List playback	132
9.2.1	Running a cue list	132
9.2.2	Killing a cue list	133

9.3	Editing cue lists	133
9.3.1	Editing a cue list using Unfold	133
9.3.2	Using Update to change tracked cues	134
9.3.3	Editing a cue list which is running	134
9.3.4	Editing a cue list while recording	135
9.4	Copying, moving, linking and deleting	136
9.4.1	Copying or moving a cue list	136
9.4.2	Deleting a cue list	136
9.4.3	Deleting a cue from a cue list	136
9.5	Cue list timing	136
9.5.1	Time and fade options for Cue Lists	136
9.5.2	Cue linking & Link Offset	137
9.5.3	Individual attribute fade times	138
9.5.4	Fixture overlap	139
9.5.5	Running a cue list to timecode	140
9.6	Advanced options	141
9.6.1	Release mask	141
9.6.2	Fader mode	141
9.6.3	Handle Paging	141
9.6.4	Cue Options	141
9.6.5	Autoload	142
9.6.6	Macro Links	142
9.6.7	Key Profile	142
9.6.8	Shape Size/Shape Speed	142
9.6.9	Tracking	142
10.	Running the show	143
10.1	Playback controls	143
10.1.1	Back up the show	143
10.1.2	Label the console	143
10.1.3	Flash and swop buttons	143
10.1.4	Playback priority	143
10.1.5	Blind mode	143
10.1.6	Manual control during a show ("busking")	144
10.2	Using multiple on-screen workspaces	145
10.2.1	View menu	145
10.3	Organising the console	145
10.3.1	Using the Move function	145
10.4	MIDI remote triggering	145
10.4.1	Connecting remote trigger sources	145
10.4.2	Setting up remote triggering	145
10.4.3	Classic Pearl MIDI triggers	147
11.	Remote control	149
11.1	Setting up the remote	149
11.1.1	Network setup	149
11.1.2	Console setup	150
11.2	Operating the remote	151
11.2.1	Keypad	151
11.2.2	Fixture List	152
11.2.3	Playback List	152
11.2.4	Settings screen	153
11.3	Troubleshooting	153
12.	User Settings and other options	155
12.1	Configuring the Workspace	155
12.1.1	Opening workspace windows	155
12.1.2	Selecting and positioning workspace windows	155
12.1.3	Saving workspaces	155
12.1.4	Compatibility view	156
12.2	Key Profiles	157
12.2.1	Creating and editing key profiles	157
12.2.2	Selecting a key profile	158
12.2.3	Individual Key profiles for playbacks	159
12.3	The System menu	160
12.3.1	Avotalk Security	160
12.3.2	Network Settings	160
12.3.3	User Settings	160

12.3.4	Key Profiles	161
12.3.5	Wipe.....	161
12.3.6	Display Setup	162
12.4	DMX output mapping	162
12.4.1	Configuring DMX outputs.....	162
12.5	Curves.....	163
12.6	Upgrading the software	167
13.	Working with Fixture Personalities	169
13.1.1	Downloading fixture personalities from Avolites.....	169
13.1.2	Updating the personality library on the console	170
13.1.3	Requesting a new fixture personality	170
13.1.4	Reporting a personality bug to Avolites	170
13.1.5	In an emergency.....	170
14.	Networking the console	173
14.1	Controlling fixtures over a network.....	173
14.1.1	Setting IP address.....	173
14.1.2	Setting up DMX outputs	173
14.1.3	A simple ArtNet system.....	174
14.1.4	Setting up an ArtNet system.....	175
14.1.5	Additional ArtNet Resources.....	176
14.2	Connecting to a simulator with ACDI	176
14.2.1	ACDI	177
14.3	Module Setup.....	178
14.4	Using Active Fixtures with CITP	178
14.4.1	Example CITP setup	178
14.5	All about IP addressing.....	179
14.5.1	Setting your IP address.....	179
14.5.2	Subnet Masks	180
14.5.3	Choosing an IP address and Subnet Mask.....	180
14.5.4	Automatically assigning IP addresses (DHCP).....	181
14.5.5	Private IP address ranges.....	182
14.6	Repairing a Network Connection	182
15.	Using different Avolites consoles	183
15.1	The console controls	183
15.2	Programming features in Titan	184
16.	Release notes	187
16.1	Version 5.0	187
16.1.1	Upgrading from: 3.1:.....	187
16.1.2	Upgrading from: 4.0:.....	187
16.1.3	New features in v.5.0	187
16.1.4	Improvements in v.5.0	191
16.1.5	Bugs fixed in v.5.0	192
16.1.6	Bugs fixed in v.4.1	193
17.	Glossary of terms	195
INDEX		201

Copyright Avolites 2011

1. Quick Start

This section is a quick guide on how to do most things on Titan Mobile. Each section has a link to take you to the appropriate manual section for more details.

Softkeys are shown in square brackets like [This].

1.1 Patching fixtures

Press Patch, [Dimmers] or [Fixtures].

For Fixtures, from the softkeys choose fixture manufacturer (type on keyboard to filter the list) then fixture type, then fixture mode.

Set [DMX Line], [Address], [User Number], and [Legend]. Console will automatically set all these if you don't change them.

Press buttons in the Fixtures window to patch the fixture. (Section 3.1.3, p35).

To patch a number of dimmers or fixtures at once, drag over buttons to draw a selection box on the screen. Or, set [Quantity] in the patch menu.

To change DMX address or line, use [Repatch Fixtures]. (Section 3.2, p37).

Setting fixture options

Press Patch, [Edit Fixtures]

1.2 Controlling fixtures

Select fixtures for control by pressing select buttons.

Press Locate to "home" selected fixtures with lamp on. (Section 4.1.2, p46). Hold locate and press attribute button to remove that attribute from the locate (e.g. to locate without changing pan/tilt, hold Locate and press Pan/Tilt).

Select attribute to control using attribute bank buttons (below the wheels), then turn the wheels to set fixture. Display shows which attribute each wheel is controlling. (Section 4.1.4, p48).

Open Attribute window onscreen (Window Open, Attribute Options) to select attributes from buttons. (Section 4.1.5, p49).

Use Palettes to store often-used colours, positions etc. for instant recall., see next page.

Shapes (effects)

Select fixtures. The order of fixture selection is used by shapes.

At top menu press [Shapes and Effects], [Shape Generator], [Create]. Select attribute of shape then select a shape to run. (Section 6.1.1, p76).

Or from the Shape Library window (Window Open, [Open Workspace Window], [Shape Library]) you can select a shape directly. Filter the list of shapes using the attribute buttons.

Use the wheels and [Adjust Speed, Size and Phase]/[Adjust Phase, Spread and Offset] to configure the shape.

Fixture Groups

Fixtures may be grouped for quick selection, press Group, [Record Group], select fixtures for group, set legend using [Provide a legend], press [Store]. Order of fixture selection is remembered for use with shapes. (Section 4.1.11, p54).

1.3 Programming cues and chases

Cues

Set up the look to be recorded.

Press Record.

Set [Record Mode] to Channel (saves only modified attributes), Fixture (saves all attributes of modified fixtures), Stage (saves all attributes of all fixtures with nonzero dimmer), or Quick Build (saves palettes and playbacks when you select them).

To store, press blue Select button on playback fader, or press button in Playbacks window. (Section 7.1.2, 106).

Chases

Press Record twice (or Record then [Create Chase]) .

Press blue Select button on a playback fader, or press button in Playbacks window.

Set up the look for the first step, press playback select button to store. Repeat until all steps stored.

Press Exit to finish storing chase steps. (Section 8.1.1, 119)

Fade timing

For chases, speed and fade can be set with wheels A and B when the chase is running.

At top level menu press [Edit Times] then the select button for the playback. Timing options are set from softkeys.

[Fixture Overlap] sets each fixture to fade in sequence (100%=all together, 0%=fixture waits for previous one to complete).

[Attribute times] sets individual fade times for different attributes.

[Fixture order] changes sequence for shapes and Overlap. (Section 8.5, p124).

Cue Lists

Cues may be stored in a Cue List which allows a full show to be run from a Go button. Chases can be included using Autoload.

1.4 Programming palettes

Set up the attributes to be recorded. If attribute is the same for all fixtures of one type (e.g. colour), only one fixture need be set up and palette will be "shared".

Press Record, Palette.

Use [Set Mask] to choose attributes to record/exclude.

Press a grey palette button to store, or press a button in one of the Colours/Positions/Gobos windows. (Section 5.1.2, p66).

To recall palette, select fixtures, select recall mask using Attribute Bank buttons, press palette button.

To set a legend, press [Set Legend] then the palette's button. Press [Picture] to draw a picture legend.

Quick Record

Press an unused button in one of the windows – the button turns red with a +. Press again to save the palette. The mask is automatically set to match the window (e.g. Positions window is masked for only position attributes).

Busking with palettes

To fade palettes when busking a show, select fixtures, type fade time on the keypad then recall the palette (you have to do this each time). If no fixtures selected, palette will recall to all applicable fixtures.

To set fixture overlap, type 0-100 then press [Set Overlap], then recall the palette.

To set a fade time for all palettes, press Palette then [Master Time]. (Section 5.5, p73). Faded palettes do not go into the programmer so don't use fades when programming.

1.5 DMX / network setup

The 12 DMX lines may be routed to the 4 XLR sockets or over Ethernet.

Switch to System mode by holding Avo and pressing Disk, press [DMX Settings].

Select a Node on the left (where the DMX is going to), click the blue arrow. On the right, select the DMX line it will be fed by. The 'i' buttons set properties for Nodes/Lines. (Section 5.5, p162).

To change the IP address of the console, press [Network Settings] in System mode (Section 14.1.1, p173).

To change User Settings which let you personalise how the console works, hold down Avo and select [User Settings] (Section.12.3.3, p160).

Copyright Avolites 2011

2. Setting up and using the console

Welcome to Titan Mobile from Avolites. This manual is a reference guide to all the functions of the console.

We explain things in the order you're most likely to use them, so we start with how to set up the console, then look at patching lights, controlling lights and how to program cues.

2.1 Guide to Titan Mobile

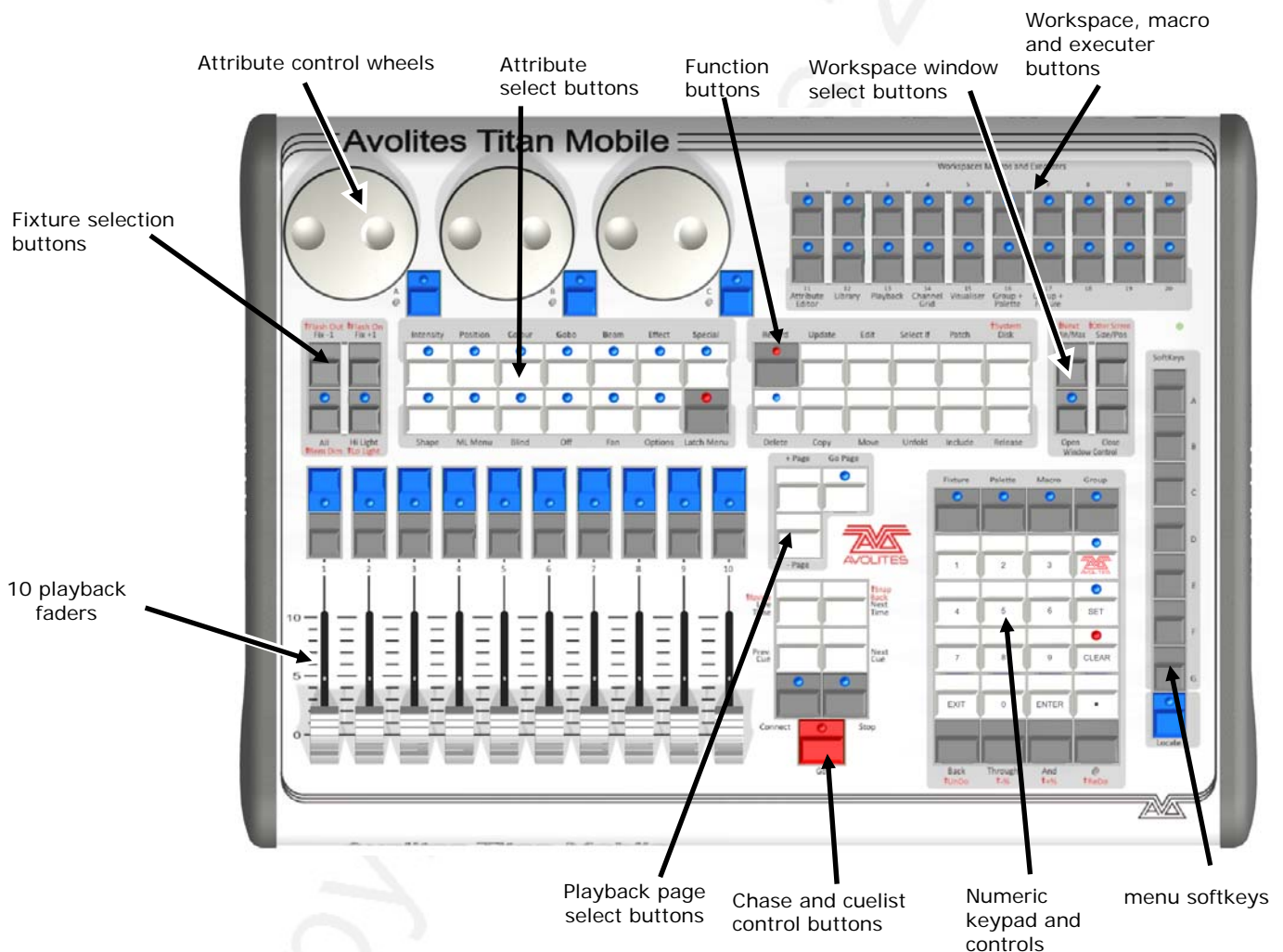

- The **Playback faders** are used to store and play back cues or chases. The **Page Select buttons** let you change to a different page of playbacks. The bottom of the screen shows information about each playback.
- The **Attribute Control wheels** are used to set control values (attributes) for the fixtures, and to set chase speeds and fades. The bottom right corner of the screen shows information about the attributes being controlled.
- The **Attribute select buttons** are used to select which attributes of a fixture (e.g. colour, gobo, position) are going to be controlled using the

Control wheels. The buttons have lights on to show you which attributes are active. Attribute functions such as Fan and Shapes are also controlled here.

- The **Chase and Cuelist control buttons** allow you to start and stop chases and cuelists, and move about in the list.
- The **Numeric keypad** and other control buttons are used to enter values and change controls on the system.
- The **Function buttons** are used to carry out functions such as storing cues, copying, saving to disk, etc.
- The **Workspaces, Macros and Executers** buttons are programmable buttons which can be used to store workspaces (screen layouts), button macros or cues.
- The **Workspace Window select buttons** are used to set which windows are shown on the screen.

The screen

The system is designed to be used with a touch screen, but may be used with a mouse - just click where the manual says 'touch'.

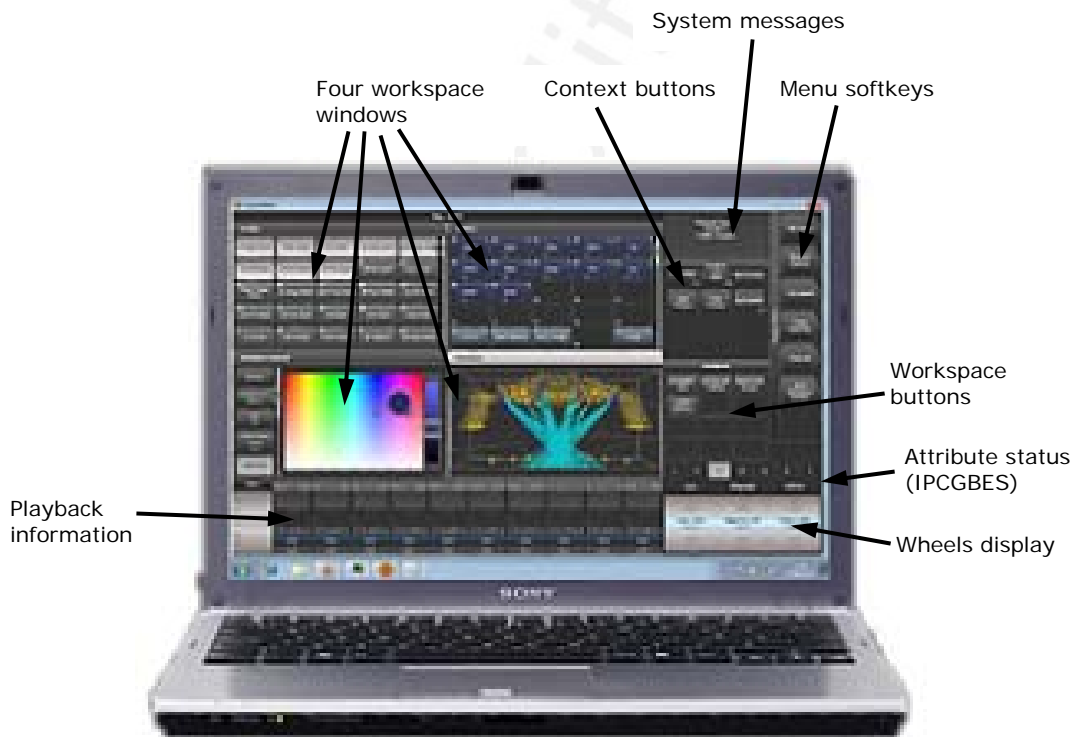

- Four **Workspace Windows** may be shown on the screen. These contain touch buttons to control fixture selection, palette selection, groups, shapes, attributes, and so on. Visualiser may also be shown in a window.
- The system **Menu softkeys** are down the top right hand side. You can select these by touching or clicking them, or by using the menu buttons on the right hand edge of the control panel.
- **System prompts** are shown just to the left of the menu keys. Below that are **Context buttons** which appear when relevant to the operation you are doing.

- The **Workspace Buttons** allow you to quickly select and save different workspace screen layouts.
- The **Wheels display** shows the current attributes available on the 3 wheels. The **Attribute status display** above that shows which attributes are currently active or modified.
- The **Playback information** shows the legend and other information about the playbacks on the 10 faders.

Connections panel

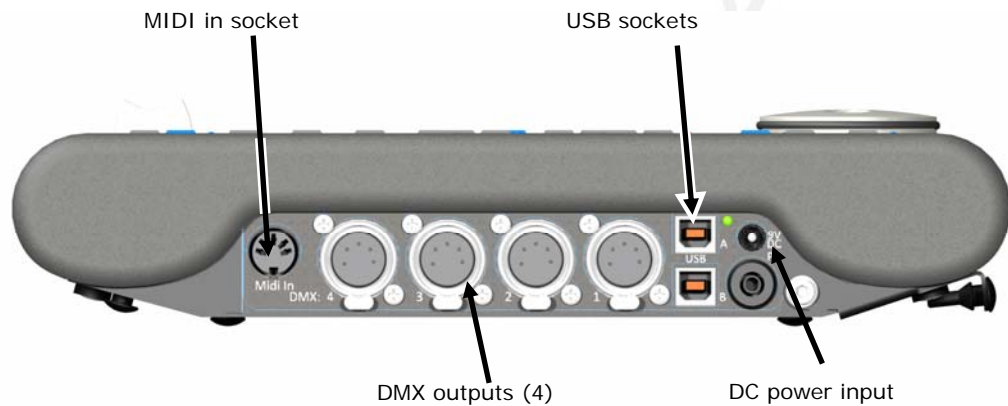

All the connections required for the control panel are found on the right hand side. Most are self-explanatory.

- Normally the panel is powered via the USB connection. Some laptop USB ports may not provide sufficient power for the panel, in which case the DC power input can be used to connect an external 9V DC power supply, available from Avolites.

2.2 Connecting up

2.2.1 Cautions



Radio transmitters may affect the operation of the console and we recommend that they are not placed on or above or behind the console. If you are wearing one it is best placed in a back pocket or behind you when attached to a belt.

2.2.2 Software installation

Do not connect the Titan Mobile panel to your PC for the first time until you have installed the Titan Mobile software, which you do simply by running the installer file. This will make sure the drivers for the panel are installed.

Having installed the software, connect the two USB cables for the panel. If your PC asks you for drivers, select 'Install the Software Automatically'.

The first time you run Titan you will need to register the security dongle in the panel with Avolites.

2.2.3 Connecting to your laptop/PC

For best usability, your PC should have a touch screen. However, if not you can use the mouse to select touch buttons.

The panel connects to the PC using two USB cables. Both cables must be connected for correct operation. Power is supplied down the USB connection, though you can connect an external DC power supply if this is needed (some laptops have limited power supply on their USB ports).

2.2.4 Connecting DMX lines

The console communicates with lighting fixtures using the DMX512 system. It can produce 12 universes of DMX (each 512 control channels). It has 4 physical DMX outputs for direct connection to fixtures and dimmers, and can also send DMX over Ethernet and wireless Ethernet systems to allow connection to remote DMX Ethernet nodes, media servers, and so on.

When you patch a dimmer or fixture you tell Titan Mobile which of the 12 DMX universes it is on. Each universe can be configured to come out of one or more of the 4 standard DMX outputs on the back of the console, or over an Ethernet protocol (see section 14 on page 173.)

By default, DMX Lines 1-4 are connected to the four XLRs on the console.

The four 5 pin XLR sockets on the console are wired like this:

Pin 1	Earth
-------	-------

Pin 2	Data -
Pin 3	Data +
Pin 4	Not used
Pin 5	Not used

Each DMX line should pass through all the fixtures to be connected on that line one after the other and have a DMX terminator fitted at the end (120 ohm resistor between pins 2 and 3). You should not split the DMX lines using passive splitters (Y-splits) as this can corrupt the data.

2.3 Using the on-screen workspace

As well as the Titan Mobile control surface, the on-screen workspace provides many useful features. The workspaces are designed to be used with a touch screen.

2.3.1 Workspace windows

The main area of the screen contains the workspace windows. These contain buttons for selecting fixtures, groups, palettes, playbacks and so on. Information windows such as Playback View and the integrated Visualiser application can also appear as a workspace window.

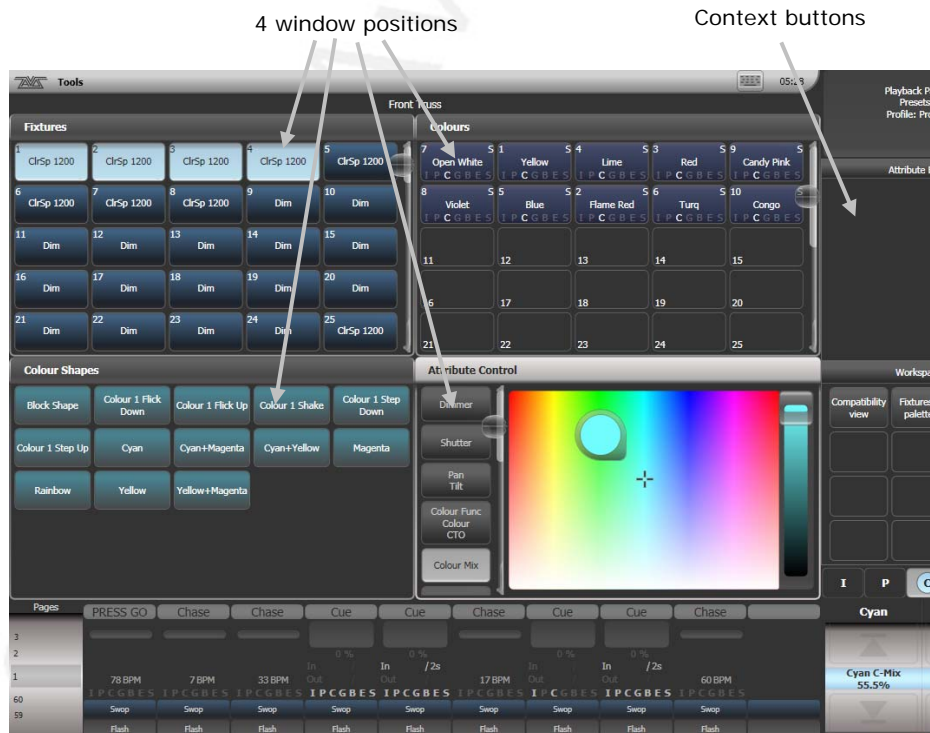

Up to 4 windows can be shown on the screen in a 2x2 grid, but if you need a larger view, you can make a window twice as big, or it can take up the whole area. Some possible window sizes/positions are shown below.

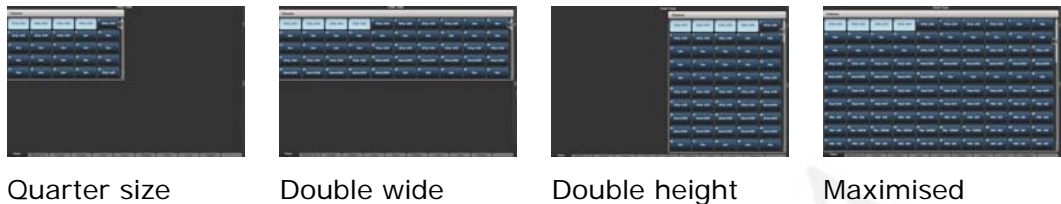

Some windows have associated control buttons, these are positioned in the “context buttons” area on the top right of the screen.

Selecting and positioning workspace windows

You select which workspace windows you want to see using the [Open Workspace Window] menu command on the root menu.

You can change the positions and sizes of the windows by using the Window Control buttons above the numeric keypad. The min/max button swaps the active window between full screen and quarter size. The size/position button moves the active window around the possible positions. You make a window active by clicking/touching its header bar.

Window shortcuts

Press Window Open then an Attribute Bank button to open the Palette window for that attribute.

Press Window Open then Patch to open the DMX output window.

Press Window Open then Connect to open the View Cue window.

Press Window Open then Macro to open the Macro window.

Workspace window options

You can change the window sizes and positions by clicking the small ‘i’ button in the top right corner of the window. These options also allow you to set the button size and the text size of the window.



Saving workspaces

You can save different workspace setups to the Workspaces touch buttons (to the left of the menu) by pressing Window Open then [Record Workspace], then touching one of the Workspaces buttons. This allows you to reconfigure the workspace at the touch of a button.

Workspaces are saved with the show.

Setting up and recording workspaces is described in more detail in section 12.1 on page 155.

Quick record

Some windows – Groups, Workspaces, Playbacks, and all the Palette windows - have a Quick Record function.

Set up what you want to record, then touch or click the button once. The button will light up red with a + sign.

At this point you can enter a legend. Touch or click again to store the item.



The Quick Record function can be disabled using Key Profiles (see section 12.2.1 on page 157).

Legends and picture legends

All touch buttons can have legends set to remind you what they do.

In addition, you can draw picture legends on the buttons. To do this, select [Set Legend] then press [Picture]. A drawing space will open on the touch screen for you to draw the legend. There is also a library of pictures to choose from including popular gobo designs.



2.3.2 The menu area of the touch screen

The right hand side of the touch screen is used for the operating menu display.

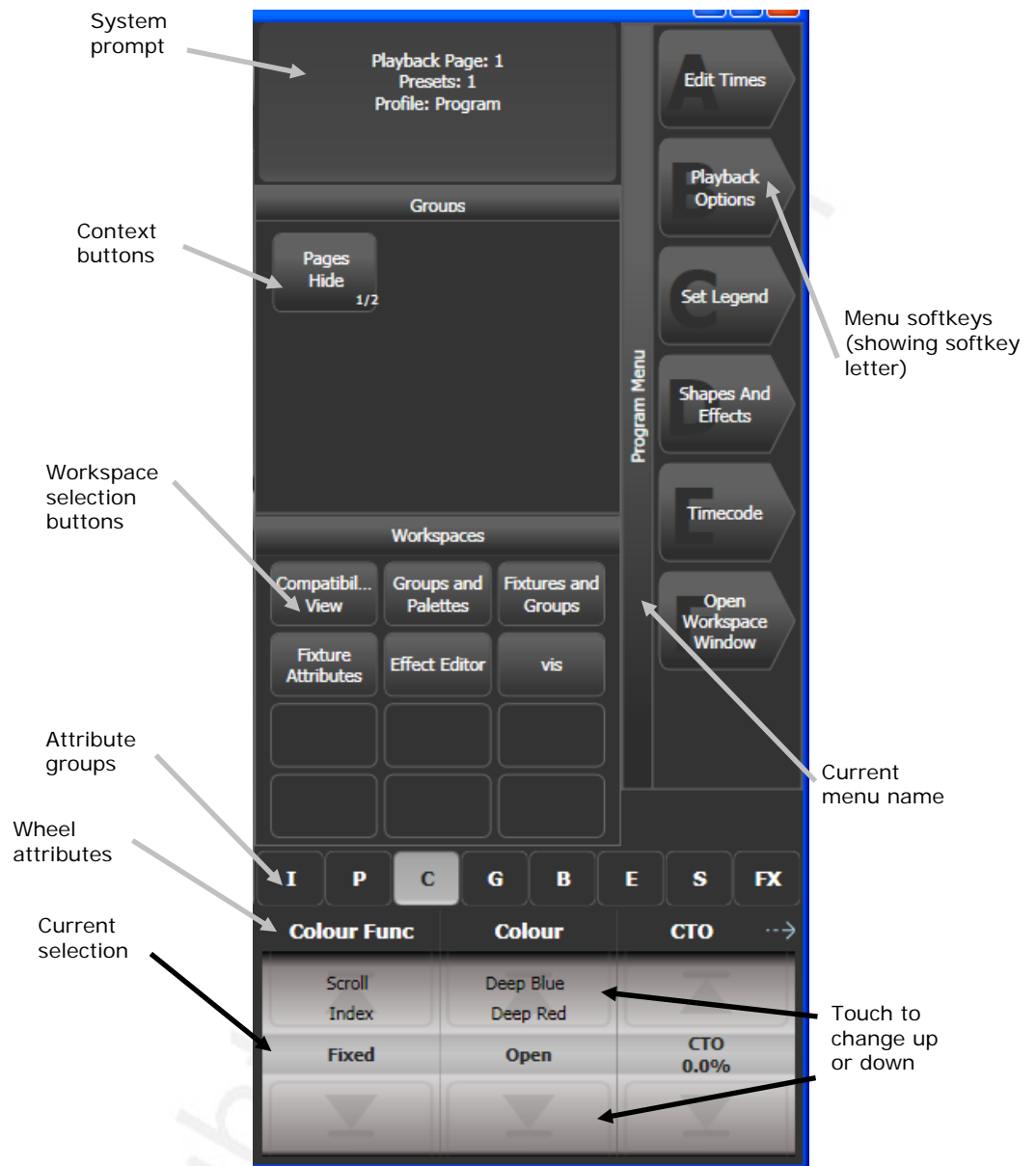

Down the right hand side of the screen, the functions of the A-G menu softkeys are listed. If there are more functions than will fit on one screen, [Previous] and [Next] buttons are provided to page through the functions. You can either press the real button or touch the key on screen.

The vertical bar to the left of the softkeys shows you which menu you are currently in. You can 'latch' the menu (so that you don't have to keep reselecting it) by pressing the Menu Latch button. The menu bar turns red when latched.

At the bottom of the screen, the current function of the wheels is shown. If fixture attributes are being set, this shows the possible settings which are available on the fixtures. Above the roller image a legend shows which attributes are being controlled by each wheel and the centre of the roller shows the current attribute. If a chase is being controlled, information about the chase is shown here.

Above this, the screen shows which attribute group (Intensity, Position, Colour, Gobo, Beam, Effect and Special) is selected (grey box) and which are currently modified (blue circle).

The area at the top of the screen shows instructions to the user and information from the console.

The appearance of the softkeys varies to indicate the type of actions available:

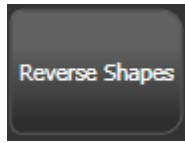

Action button: console will carry out the action shown

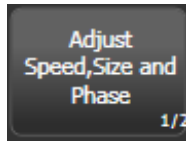

Option button: cycles through a range of options

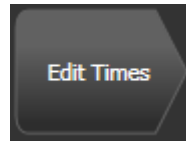

New menu button: jumps to a new menu



Text entry button: press and enter text using the touch keyboard

2.3.3 The Heads-Up Display (HUD)

The HUD window is shown as one of the workspace windows. Most of the HUD information is now shown in other windows, but if you're used to using it you might like to have it displayed.

Fixtures are highlighted in dark blue if in the programmer and in light blue if selected.

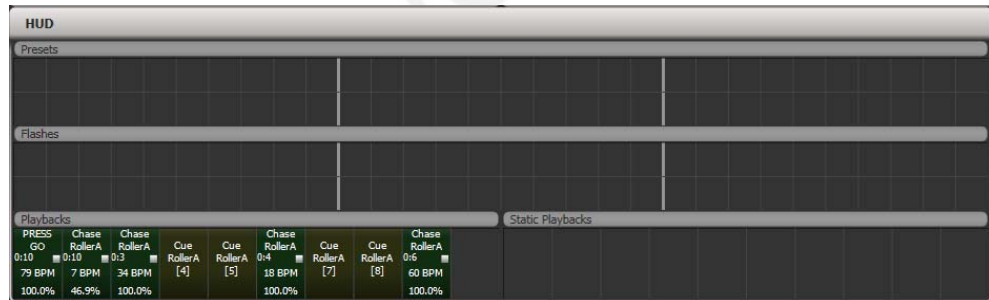

2.3.4 Visualiser

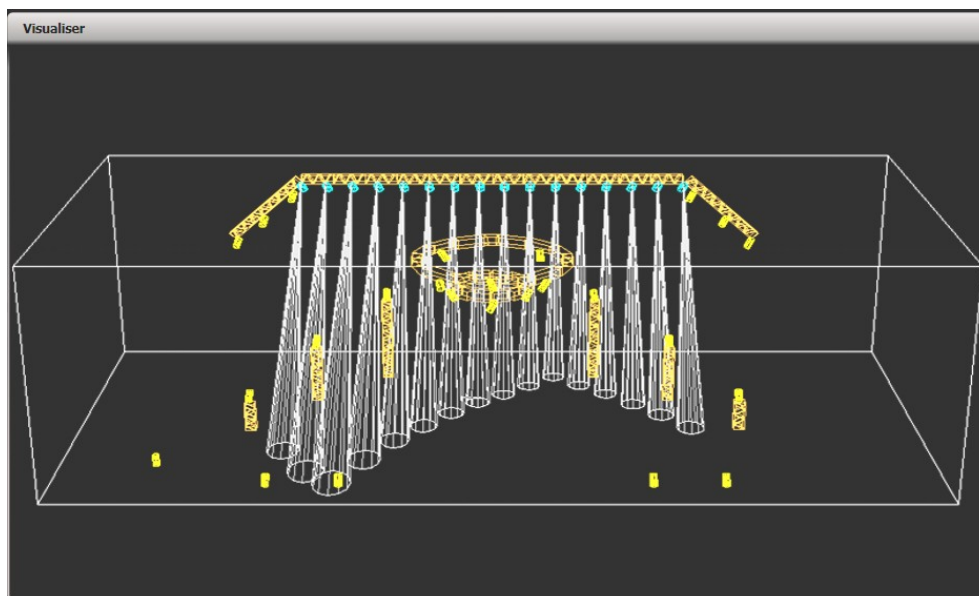

The console runs Avolites Visualiser internally. This allows you to view the output of the console if you can't use the real lights, enabling you to make changes to your show at home or in your hotel. It can also be used in Blind mode for programming during a show.

Configuration buttons for Visualiser are provided in the context button area to the left of the menu buttons.

The operation of Visualiser is not covered in this manual, please refer to the Visualiser manual.

Auto Patch

The Auto Patch function automatically creates a Visualiser rig from your show as you patch fixtures. When you start Visualiser, it will open with an automatic representation of your patch.

You will see the fixtures laid out on screen with 60 fixtures in a row, sorted by handle number.

The Visualiser will start in run mode, with the simulator tab selected so you can start controlling lights immediately.

Multiple dimmers patched to one handle will appear as a single fixture in Visualiser.

Fixture selection

When a fixture is selected on the console, it is highlighted in blue in Visualiser.

2.3.5 Key profiles

The console allows you to change the function of the blue select and grey flash panel buttons. You can also change the way some of the touch keys work. You can save your settings as a Key Profile. Different profiles can be selected for different users or to enhance the operation of the console for a particular use. See section 12.2 on page 157 for details.

2.3.6 Undo/Redo

You can undo and redo up to 20 actions by pressing Avo shift and the Undo or Redo buttons below the numeric keypad (on black Pearl Expert consoles these are the Left arrow (Undo) and Right arrow (Redo) buttons). So for example if you press Clear then wish you hadn't, the Undo function will restore the console state.

You can use undo/redo on the following actions:

- Fixture selection
- Attribute adjustment (eg Pan, Tilt, colour changes)
- Locate
- Clear
- Keypad input
- Applying Palettes
- Group selection
- Off
- Align
- Flip

2.3.7 Key macro buttons

Lighting programming can sometimes require a repeated sequence of button presses. You can record sequences of keypresses and play them back with a single keypress – this is called a macro.

Macros can be stored in the 20 dedicated buttons on the top right of the panel, and there is also a Macro button window which can be shown in the workspace. The macro buttons correspond to the first 20 macros in the window.

To record a macro:

-
- 1> *Press the Macro button*
 - 2> *Press [Record]*
 - 3> *Press an empty Macro button on the panel, or an empty button in the Macro window on the screen. Recording starts. The Insert/Macro button flashes during recording.*
 - 4> *Press the sequence of buttons you want to record.*
 - 5> *Press Record Macro to finish recording.*
-

To play back the macro, just press or touch the button where you recorded the macro. The macro will repeat all your button presses (with no delay or timing between the presses).

2.3.8 Keyboard shortcuts

Many features of the console can be controlled by shortcuts on the keyboard. These are especially useful when using Titan Mobile or Titan Simulator.

The Titan application “captures” the keyboard on start up, meaning that if you try to use other applications at the same time they will not

receive keypresses. Pressing Break on the keyboard releases the keyboard for other applications but disables all text entry for Titan including the shortcut keys; changing menus will reconnect the keyboard to Titan.

F1	Move to other screen	Ctrl X	Cut text
F2	Activate window	Ctrl C	Copy text
F3	Minimise/Maximise	Ctrl V	Paste text
Shift F3	Next window	Ctrl A	Select all text
F4	Size/Position	Ctrl Z	Undo
Shift F4	Move to other screen	Ctrl Y	Redo
F5	Close window	Alt C	Clear
Shift F5	Close all windows	Alt R	Record menu
F6	Open Playbacks window	Alt A	Toggle Avo (shift) menu
F7	Open Fixtures window	Alt L	Locate
F8	Open Groups window	Alt P	Patch
F9	Open Colours window	Alt ↑ D	Disk menu
F10	Open Positions window	Alt ↑ S	System mode
F11	Gobos/Beams window	Alt V	Open/View menu
F12	Open Channel Grid	Alt G	Go
Esc	Exit menu	Alt D	Delete
Enter	Enter	Alt ↑ C	Copy
Alt 1	Softkey A	Alt M	Move
Alt 2	Softkey B	Alt U	Unfold
Alt 3	Softkey C	Alt I	Include
Alt 4	Softkey D	Alt ↑ R	Release
Alt 5	Softkey E	Alt S	Shape
Alt 6	Softkey F	Alt T	Fixture Tools/ML Menu
Alt 7	Softkey G	Alt B	Blind
Alt ↑ F	Fixture	Alt O	Off
Alt ↑ P	Palette	Alt F	Fan
Alt ↑ M	Macro	Alt ↑ O	Attribute options
Alt ↑ G	Group	Alt ↑ L	Latch menu
/ (num)	Thro	Alt ←	Previous fixture
* (num)	@	Alt →	Next fixture
- (num)	Not	Alt ↑	All
+ (num)	And	Alt ↓	Highlight

↑ means shift

(num) means on the numeric keypad

2.3.9 Locking the console

You can lock the console controls to prevent people fiddling with it while you're not looking. Hold down Avo and press [Lock], then type a password (numbers or letters). To unlock, enter the password again, or restarting the console will also unlock it.

While the console is locked, all functions are disabled except the DMX outputs and currently running playbacks.

2.4 Titan Simulator

Need to pre-program or tweak your show before you get to the venue? No problem, just run the Titan Simulator on your PC. You can then load your show and simulate any of the Titan consoles, using an on-screen "virtual panel".



2.4.1 Installing Titan Simulator

You will need a user account with Administrator privileges to install or run Titan Simulator.

Simply download and run the installer from the Avolites Download website. The first time you run Simulator you will need to license the software with the Avolites website. For this you will need an account set up on the Download site, which you should go and create now if you don't already have one.

To license the software, start Titan Simulator and choose Internet Activation (the software will ask you for your Avolites Download user name and password and automatically retrieve your license), or Manual Activation (you have to copy and paste the Computer Key into the form on the Titan Simulator webpage).

Once licensed Titan Simulator will run in 'Offline' mode which is shown towards the top right of the screen. In Offline mode the software will function as normal including Visualiser and Art-Net outputs. However periodically random DMX values will be sent down all DMX outputs, please wait for this to stop before continuing programming.

2.4.2 Running Titan Simulator

When you start the simulator you need to select which console you are simulating. The simulator will then open a Virtual Panel for your chosen console and monitor windows for each of the monitor outputs.



The Tiger Touch simulator shows the touch screen display separately from the Virtual Panel.

The Virtual Panel works exactly the same as the real panel; to hold a button down so you can press a second button, right click it using the mouse.

2.5 Loading and saving shows

You can save any number of different shows on a USB drive or the console's internal hard disk. The console will also autosave the show periodically.



Shows created on Titan Mobile can be loaded into any other Avolites Titan console, but not to non-Titan consoles as the showfile format is different.

Although your show is safe on the hard disk, it's a good idea to also save it to a USB pen drive which you can take with you in case something bad happens to the console or if you want to transfer a show to a different console.

2.5.1 Manual save and load

You can save your show at any time either with its current name or with a new name.

-
- 1> *Press the Disk button.*
 - 2> *Press [Save Show].*
 - 3> *If you have a USB drive connected, use the softkeys to select whether to save on [Removable Disk] or [Internal hard drive].*
 - 4> *Enter a name for the show on the keyboard (the screen shows a list of shows which already exist).*
 - 5> *Press Enter or [Save] (or [Overwrite] if the show already exists). The show will be saved.*
 - 6> *Press Exit or [OK] to leave Disk mode.*
-

If you save to hard drive, shows are saved in the folder 'My Documents/Titan Show Files', unless you change this in the User Settings.

The console will automatically reload the last show when it is turned on.

If you want to load a different show:

-
- 1> *Press the Disk button.*
 - 2> *Press [Load Show].*

- 3> *If you have a USB drive connected, select which drive you want to load from.*
 - 4> *Available shows are listed on the softkeys; press the key to load the show (the F and G keys show more pages). If you type the first few letters of the show name on the touch keyboard, the list will only include shows starting with those letters, which can make it easier to locate the show you want.*
 - 5> *Press Exit to leave Disk mode.*
-

2.5.2 Autosave

The console will automatically save your show to its internal hard disk when you shut it down. It will also autosave the show every 30 minutes in case the console loses power. The time remaining to the next auto save is shown on the status bar of the Titan application.

You can disable Autosave or alter the time between saves using option [Auto Save] on the Disk menu (selected using the blue Disk button). Softkey A enables or disables autosave and Softkey B sets the time between saves.



We recommend that you have autosave enabled while programming in case the console power fails, but disable it while running a show as it can cause the console to pause slightly at inconvenient moments.

2.5.3 Backing up existing show files to USB pen drive

If you just want to save a copy of your current show, you can use the normal save function to save it to the USB drive instead of the hard drive.

To copy an existing show file on the hard disk to a USB drive, first ensure your current show is saved, then use the Disk functions to load the existing show from hard disk, then save it to the USB drive. Alternatively you can use the Folders command on the Tools menu.

2.6 Clearing the console

When you start a new show on Titan Mobile it is usually a good idea to clear the console. All programming and patching is deleted, but user options are not changed.

- 1> *Press the Disk button.*
 - 2> *Press [New Show].*
 - 3> *Press [OK] to confirm.*
 - 4> *Press Exit to leave Disk mode.*
-

- There is also an option [Wipe] in the System menu (when the console is in System mode) which has the same function, and is located in the same place as on other Avolites consoles.

Copyright Avolites 2011

3. Patching

Patching is the process where you tell Titan Mobile

- What type of lighting units you have connected to it
- What DMX addresses they are operating at
- Which DMX line (universe) each unit is connected to (there are 12)
- Which buttons on the console you want to use to access them (either physical buttons or touch buttons)
- Particular option settings for each fixture.



Before you start rigging, use the console to work out the DMX addresses for the fixtures in your rig. Patch them on the console (or simulator), then press View, [Fixture Patch] to show the addresses. This will use the DMX channels as efficiently as possible without leaving any gaps.

3.1 Patching new fixtures or dimmers

3.1.1 Fixture select buttons and handles

To control intelligent fixtures or dimmer channels, they must be patched to a fixture button in the Fixtures workspace window.

If the Fixtures window is not shown, press Window Open then [Show workspace window] then [Fixtures].



Fixture buttons can be shown either in pages with Page buttons, or you can use the scroll bar on the right to show different pages. Use the [Pages Show/Hide] button on the right of the screen to select between page buttons and scrolling mode. You can change the fixture page at any time.

You can allocate fixtures and dimmers to Groups, which allows you to quickly select a set of fixtures with one button. Groups are described in the next chapter.

3.1.2 Patching dimmers

Each fixture button can control single or multiple dimmer channels.

- 1> Press Patch (one of the white function buttons above the numeric keypad), then [Dimmers].
- 2> Softkey A [DMX Line=] shows you which of the 12 DMX output lines you are patching onto. Press A then enter a new number (1-12) to change the line. Softkey B shows the DMX address about to be patched. You can change this by pressing B [Address=xx], typing in the new address on the numeric keypad and pressing Enter.



- 3> To patch a single dimmer, press a Fixture Select button. To patch a sequence of dimmers each to its own button, press [Quantity] and set the number of dimmers then press the first select button. Alternatively, run your finger across the buttons on the screen. The range of dimmers will be patched to sequential DMX addresses.
 - 4> The Select buttons turn dark blue and show fixture details when they are patched.
 - 5> Repeat from step 2 for other dimmers.
-
- When setting the DMX address using Softkey B, you can set the DMX line (universe) as well by entering {line}.{DMX}, for example 2.56 will set DMX address 56 on DMX line 2.
 - To see how DMX channels are patched, press Window Open (next to the numeric keypad) then [Fixture Patch]. The fixture patch view is described in section 3.2.3 on page 38.
 - C [User Number = xx] allows you to set a user-defined number for each dimmer or fixture patched, to help you identify them later. You can also edit the User Number from the Repatch Fixture menu.
 - You can patch multiple dimmer channels to a single handle. This can be useful if, for example, you want to control all the lights for one area together. To do this, just press the same Fixture Select button again when patching the new dimmer channel.

You can tell the dimmer channel has patched OK because the DMX address will increase by 1.

3.1.3 Patching moving light fixtures

Moving light fixtures are more complicated to patch than dimmers because they have more attributes to control, such as pan, tilt, colour etc., whereas a dimmer channel just has intensity.

Avolites consoles use a "personality" system to control fixtures. This means you don't have to know how each fixture works, you just tell Titan Mobile what you want to do and it will send the right control commands. The console has built-in personalities for most types of fixture, which tell it what attributes are available and how to control them. If the console does not have the personality for your fixture, you can download further personalities from the Avolites website or Avolites can create one for you. See section 13 on page 169 for details of how to find personalities.

- 1> Press Patch (one of the white function buttons above the numeric keypad).
- 2> Press [Fixtures].

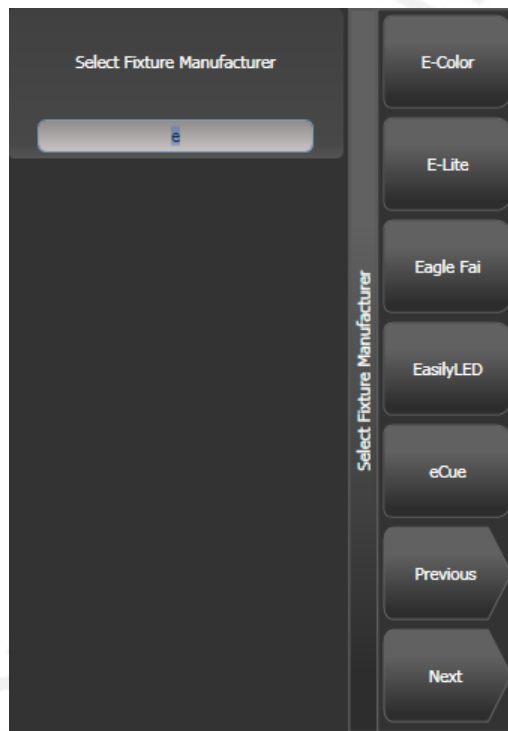

- 3> Select the correct fixture manufacturer from the softkeys ([Previous] and [Next] page through the list of manufacturers). Or use Quick Search and type the first few letters of the manufacturer's name on the keyboard to find the one you want.
- 4> Select correct fixture from the softkeys (F and G show other pages). You can use Quick Search here as well.
- 5> Select the correct fixture operating mode from the softkeys.
- 6> Softkey B shows the first free DMX address. Type the new address on the numeric keypad if you want a different one. Press A [DMX line=xx] to patch to a different DMX line, or you

can enter the address as [line].[address], e.g. 2.45 would set address 45 on line 2.

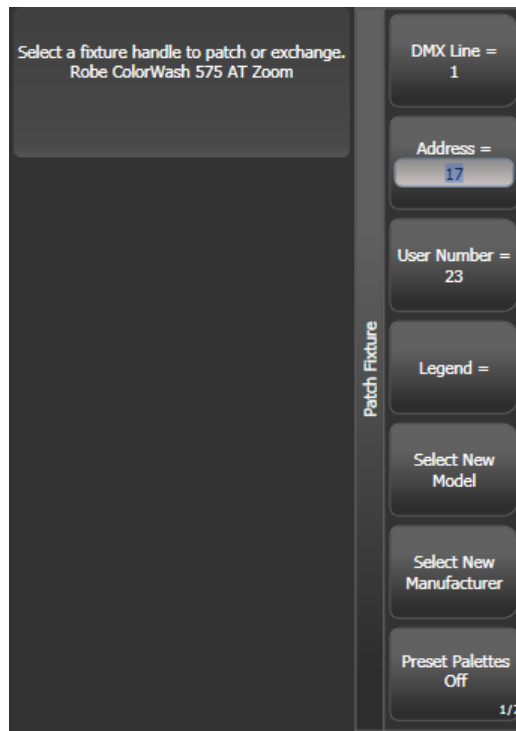

- 7> Press a Fixture Select button to patch the selected fixture.
- 8> The Select button turns dark blue and shows fixture details when it is patched.
- 9> Repeat from 7 to patch more of the same fixture type. The DMX address automatically updates so you can just keep patching by pressing Select buttons.

- You can patch a number of fixtures in one go using the [Quantity] button, or by running your finger across the buttons on the screen, in the same way as for dimmers.
- You cannot patch more than one fixture onto a button. If the button is already used, the patch will fail.
- If you are patching a fixture which uses a separate dimmer channel, such as a VL5, you can patch the dimmer channel onto the same handle as the moving light part of the fixture so you can control it all together. This is called a Pending Dimmer.
- [Options], [Preset Palettes] sets whether the console will create default colour, gobo and position palettes for the new fixture. These are created in the Position, Colour and Beam workspaces.
- [Options], [AutoGroups] sets whether the console will automatically create groups from the fixtures you patch. If Enabled, a group is created for all fixtures of the same type, and another if you patch a quantity of fixtures.
- To show the DMX address for fixtures, press Window Open then [Fixture Patch].
- If a patch goes over the capacity of a DMX line, the console will patch at the beginning of the next line. For example if you try to patch a Mac500 at channel A510, it will actually be patched at B1.

3.1.4 Visualiser Auto Patch

If you want to use Visualiser, start it by pressing Window Open then [Open Workspace Window] then [Visualiser]. Visualiser will open in one of the workspace windows with an automatic representation of your patch.

You will see the fixtures laid out on screen in handle number order. You can then use the Visualiser controls to reposition the fixtures if you wish.

3.1.5 Sub fixtures

Some fixtures have multiple cells of control within a single fixture (for example an RGB LED blinder). To avoid having to patch every cell as a single fixture, you can patch the whole fixture as one "super fixture" and each cell will then appear as a "sub fixture". This is very useful when laying out fixtures for use with the Pixel Mapper as it allows you to move and rotate the fixture as a single fixture, but keep individual control over the cells.

To access the sub fixtures, press Unfold then the select button of the fixture. The current page of fixtures will be replaced by select buttons for each individual fixture cell.

To go back to normal, press Unfold then [Exit Unfold].



The Sub fixtures feature requires an updated personality file. If sub fixtures does not work on your fixture you may need to obtain the latest fixture personality from Avolites.

3.2 Changing the patch

3.2.1 Changing the DMX address of a fixture

You can re-patch a fixture to a different DMX address or a different DMX output line. All programming is kept.

- 1> Press Patch (if you're not already in Patch mode).
- 2> Press [Repatch Fixtures].
- 3> Press the Select button of the fixture you want to change.
- 4> To change DMX press [Address], type the new address and press enter. If this address is already in use, a warning icon will be shown.



- 5> To change the DMX output line, press [DMX Line=x] and enter a new output line number 1-12.
- 6> Press Enter or [Repatch] to confirm the change.
- 7> Repeat from step 3 if you want to change other fixtures.

- You can “Park” the fixture using [Park]. This removes the fixture from the DMX output map, but all programming is retained.
- If the new DMX address already has another fixture or dimmer patched on it, the console will warn you (unless this is disabled in User Options, see section 12.3.3 on page 160). You can either press [Select another DMX address] to abort the change or [Park Conflicting Fixtures]. All programming for the parked fixture is preserved, but you need to repatch it to a free DMX address using the above procedure before you can use it again. If you press [Always Park Conflicting Fixtures] the console will park this and any future conflicting fixtures without warning you. (You can change this option back in the User Settings).

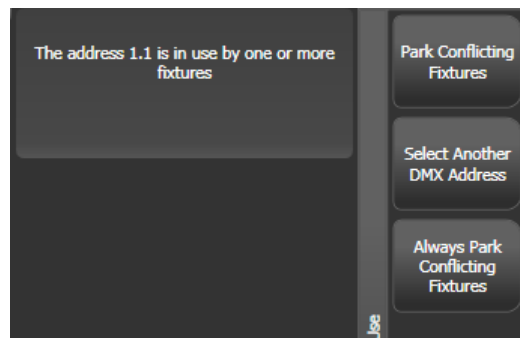

3.2.2 Setting legends

You can set a legend for each fixture or dimmer you've patched which is displayed in the Fixture Select touch button. This can be really useful to help you identify the fixture.

-
- 1> At the main menu press [Set Legend].
 - 2> Press the Select button for the fixture you want to legend.
 - 3> Type the legend on the keyboard.
 - 4> Press Enter when you have finished.
-

- You can set the same legend for multiple fixtures by selecting a group of fixtures after pressing [Set Legend].
- You can automatically allocate User Numbers for multiple fixtures by selecting a group of fixtures, then using softkey A on the Set Legend menu. The first fixture will have the User Number you entered, and the other selected fixtures will be given a number increasing by 1 for each fixture.
- You can set a legend for the current page of fixtures using the [Set Legend] function from the main Program menu. The legend is shown on the touch button for the page and on the HUD.

3.2.3 View Fixture Patch

The fixture patch view allows you to see and edit how fixtures are patched on the console.

To open the fixture patch view, press the white Window Open button (next to the numeric keypad) followed by [Fixture Patch]. You will get a table on the touch screen showing all your fixtures. The list of fixtures can be filtered by typing in a search term on the keyboard.

You can also use the wheels to scroll around the list and select different fixtures, or touch the list or one of the fixture buttons. As you select a fixture its button will be highlighted in red. You can edit the selected item by pressing [Edit]. This option toggles between [Edit] and [Search] modes.

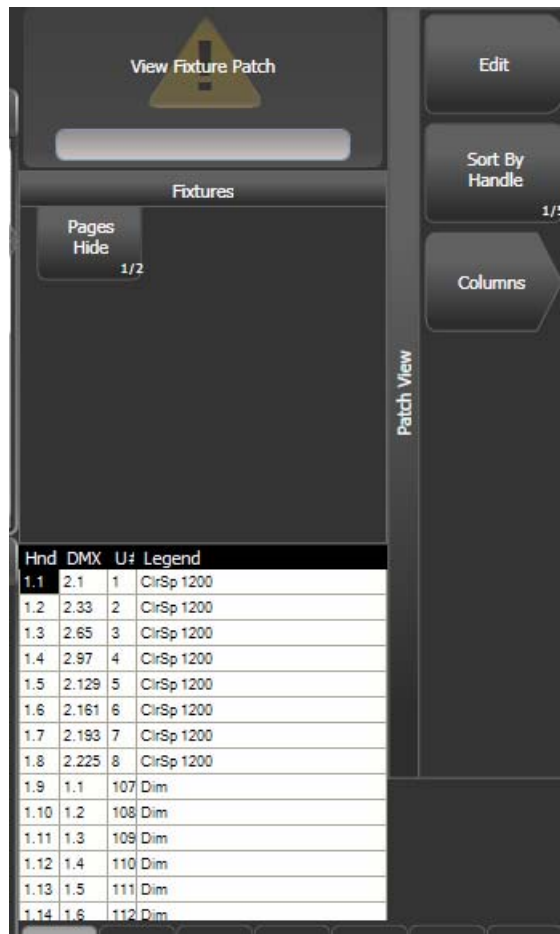

- Please note that some values are input in the following form:
-Handle Number: {Page} . {Index}
-DMX address: {Universe} . {Address}.
- You can choose which columns are displayed by pressing [Columns] and choosing which columns to hide or show.
- You can Park a fixture by moving to its DMX address and deleting the address using the left arrow key (or backspace on the keyboard).

3.2.4 DMX view window

When you're having problems getting fixtures to work it can be useful to see the actual DMX output values coming from the console. Press Window Open, then [Open Workspace Window], then select [DMX].

Line	Index	Line	Address	Control	Output
Line 1	1	1	1	Dimmer	227
Line 2	2	1	2	Dimmer	0
Line 3	3	1	3	Dimmer	196
Line 4	4	1	4	Dimmer	0
Line 5	5	1	5	Dimmer	0
Line 6	6	1	6	Dimmer	0
Line 7	7	1	7	Dimmer	30
Line 8	8	1	8	Dimmer	0
Line 9	9	1	9	Dimmer	0
Line 10	10	1	10	Dimmer	0
Line 11	11	1	11	Dimmer	0
Line 12	12	1	12	Dimmer	0
	13	1	13	Dimmer	0
	14	1	14	Dimmer	0
	15	1	15	Dimmer	0
	16	1	16	Dimmer	0

The buttons on the left let you select the different output lines from the console. Scrolling the window to the right shows more information about each DMX channel.

3.2.5 Fixture Exchange

The Fixture Exchange function enables you to repatch fixtures in your show using alternative fixtures, retaining important elements such as cue times, shapes and legends. This is very useful for touring shows and venues with a high turnover of events.

For example, if you have programmed your show in a venue which has MAC 500s and are moving to a venue with VL6s you can exchange the MAC 500s for VL6s whilst retaining many elements of your show.

Fixture Exchange works best if you use Palettes to create your cues. This allows you to adjust for position differences and so on by reprogramming a few position palettes, rather than having to reprogram every cue. Cues recorded with absolute values will need to be re-recorded, preferably using palettes.

The pan, tilt and dimmer will always be preserved from one fixture type to the next, as will times, shapes and legends for recorded items. Links from the palettes to groups, cues, chases and cue lists will also be preserved, so the show can be easily recreated by updating your palettes as normal.

Fixture exchange also gives you a powerful way to re-use an existing show with new lights, so you can give yourself a programming head start when faced with a new fixture.

- It's a good idea to save your show before performing major changes such as fixture exchange. Should you change your mind or have problems, you will easily be able to return your show to its previous state.

-
- 1> *Enter patch mode by pressing Patch.*
 - 2> *Select the new fixture type you wish to use.*
 - 3> *Touch the select button of the fixture which is to be exchanged.*
 - 4> *The console will warn you that the fixture is in use. Press the [Exchange Fixture] option.*
 - 5> *Repeat from step 3 to exchange other fixtures with the same type of new fixture.*
-



After exchanging fixtures you need to update the palettes which used those fixtures. If you have trouble switching values off in a palette, set new values for all the attributes in the attribute group and re-record the palette. You should then be able to switch off an attribute group as required.

3.2.6 Update personalities

This option allows you to update the personality for a fixture used in your show. Normally a copy of each fixture personality in the show is saved in the showfile, so updating the personality library on the console does not update fixtures which are already patched.

- It's a good idea to save your show before using Update Personalities, then you will be able to undo any changes if you change your mind or have problems.

-
- 1> *Enter patch mode by pressing Patch.*
 - 2> *Press [Update Personality].*
 - 3> *The console shows you a list of personalities used in the show which can be updated.*
 - 4> *Press the personality you want to update.*
-

- The new personality is loaded from the Titan/Personalities folder.

3.3 Copying, moving and deleting fixtures

3.3.1 Copying or moving a patched fixture

Using the Copy button you can make a copy of an existing fixture or move it to a new button. You cannot link fixture buttons. You can copy or move multiple fixtures in one operation.

Move is useful for tidying up the console.

-
- 1> *Press the Copy button.*
 - 2> *Select [Copy] or [Move]. Pressing the Copy button again will also toggle through these options.*
 - 3> *Press the Select button of the fixture you want to copy/move. You can select multiple fixtures.*
 - 4> *Press the empty Select button where you want it to go.*
-

- The Menu Latch button latches the Copy/Move/Link menu, so you can keep copying or moving things without having to keep pressing the Copy/Move/Link button. Press again to unlatch.
- There is also a Move button for instant access to the move function.
- The [Retain Layout] or [Bunch Up] option is used when copying a group of fixtures with empty handles in the group – you can either keep the empty handles, or bunch up the used handles together.
- When in Copy mode, option [Copy Legends] can be changed to [Don't copy legends] so that the copied fixtures are given default legends.
- When in Move mode, [Swap Items if Required] will attempt to reposition any existing handles which are in the way of the move. This is useful when rearranging buttons on a page which is nearly full.

3.3.2 Using copied fixtures

Fixture copying is very useful if you need an additional fixture of a type you've already patched and programmed. The new copy will come complete with all the cues and palettes of the original fixture you've copied.

The copied fixture will be "Parked" (have no DMX channel allocated) and you will need to repatch it before you can use it (see section 3.2.1 above).

3.3.3 Deleting a patched fixture

You can delete a fixture or dimmer from a button if you patched it accidentally or if you change your rig and want to use the button for something else.



All programming for the fixture is also deleted. You cannot undo deletion of a fixture or get the programming back by repatching a fixture to the same handle.

If you think you might need the fixtures again later, copy them to an unused fixture page.

-
- 1> *Enter Patch mode by pressing the Patch button.*
 - 2> *Press the Delete button.*
 - 3> *Press the Select button of the fixture you want to delete.*
 - 4> *The button will light up red and the console asks for confirmation. Press the Select button again to confirm.*
-

- You can delete a range of fixtures in one operation.

3.4 Advanced options

3.4.1 Swap pan and tilt

This allows you to make the pan channel control tilt and the tilt control pan. This can be useful for fixtures rigged in strange orientations.

-
- 1> Press Patch.
 - 2> Press [Edit Fixtures]
 - 3> Press [Swap Pan and Tilt].
 - 4> Select the fixtures to be pan-tilt swapped. Press [Pan and Tilt ...] to select either [Swapped] or [Normal] for the selected fixtures.
 - 5> Press Exit when finished.
-

3.4.2 Invert attributes

This option inverts individual attributes of fixtures. Useful if you have a fixture which pans right when the rest pan left, saving a trip up the rig to set fixture options, but you can invert any attribute.

-
- 1> Press Patch.
 - 2> Press [Edit Fixtures].
 - 3> Press [Invert Attribute]
 - 4> Select fixture(s) to be changed.
 - 5> Select the attribute to invert from the softkeys. The display shows [Inverted] when the attribute is inverted.
 - 6> Press Exit to finish.
-

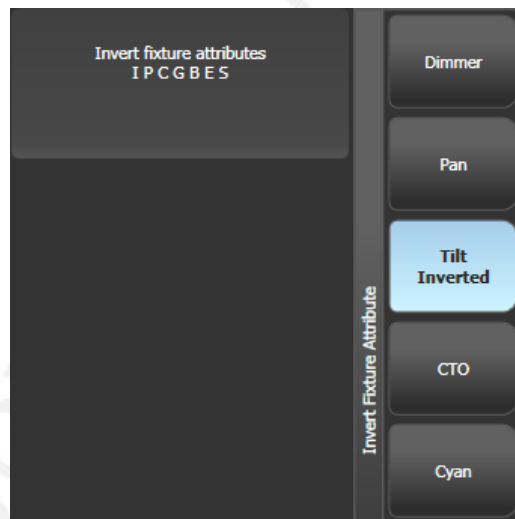

- You can change the invert on multiple fixtures by selecting more than one, but the “Inverted” display will not show if there is a mixture of inverted and non-inverted fixtures in the selection.
- Some attributes cannot be inverted.

3.4.3 Freeze fixtures or attributes

This option allows you to freeze individual attributes of a fixture, or to freeze the whole fixture. Attributes or fixtures which are frozen are not affected by playbacks or by the programmer.

-
- 1> *Press Patch.*
 - 2> *Press [Edit Fixtures]*
 - 3> *Press [Freeze Fixture or Attribute].*
 - 4> *Select the fixtures to be frozen/unfrozen.*
 - 5> *Use the softkeys to select which attributes are frozen, or to freeze the whole fixture. Frozen attributes are indicated on the softkey.*
 - 6> *Press Exit when finished.*
-

3.4.4 Editing the personality

Sometimes you may find a fixture personality contains errors and needs editing. You can edit personalities directly on the console.

-
- 1> *Press Patch.*
 - 2> *Press [Edit Fixtures]*
 - 3> *Press [Edit Personality].*
 - 4> *The softkeys show a list of all fixture types patched in your show. Select the fixture type to be edited.*
 - 5> *Personality Builder will open allowing you to edit the personality.*
 - 6> *When you save changes, your show will be updated with the edited personality. Your changes are also saved to the fixture library on the console.*
-

- A separate user guide for Personality Builder is available from the Avolites website.

4. Controlling dimmers and fixtures

When you are programming a show, and sometimes when you are running a show, you need to manually control the fixtures and dimmers to set the intensity, position, colour, etc. To do this you first select the fixtures you want to change using the select buttons, then you set the attributes of those fixtures using the Wheels and Attribute buttons.

4.1 Using the select buttons and wheels

4.1.1 Selecting fixtures and dimmers for control

To select the fixtures or dimmer channels that you want to control, you use the Fixture Select buttons to select the fixtures into the Editor. You can select fixtures or dimmers individually, or several at once.



- 1> Press the Select buttons for the fixtures you want. The select button will light up pale blue for selected fixtures (they are also shown in light blue on the HUD).
- 2> To select a range of fixtures, slide your finger across the touch buttons. To select a large number of fixtures you can touch and hold the Select button for the first fixture, then touch and hold the Select button for the last fixture, then release the button for the first fixture.

Here are some other things to know:

- Press Locate (at the bottom right of the console) to light up the selected fixtures in open white and move them to a central position. See the next section for more Locate options.
- You can deselect a fixture by pressing the select button again.
- At the top of the touch screen just above the top windows, the console will show you which fixtures are currently selected.
- Press Clear (right of numeric keys) to deselect all fixtures and remove all changes from the programmer. See the next section for more Clear options.

- Once you have changed any attribute, pressing a Select button will deselect all fixtures and start the selection process again. All previously selected fixtures (since you last pressed Clear) stay in the programmer. Once a fixture has been edited, the button shows a darker blue (also on the HUD). The picture below shows the first two fixtures selected, with the second three in the programmer and the others unselected.
- You can select fixtures on another page by touching one of the page buttons to the left of the fixture buttons, if you have 'Pages' set to Show (using the context button to the left of the menu buttons). Otherwise you can use the scroll slider to show other pages.



- Using Key Profiles (see section 12.2.1 on page 157) you can set the fixture touch button to latch mode so that it turns the fixture's dimmer channel on (like putting a preset fader to full).

4.1.2 Setting fixtures to a start position (Locate)

The Locate button (the button on the bottom right corner of the console) is used to put the fixture into a known position with light coming out, so that you can start programming it.

A quick press of the button will move all selected fixtures to a central position and reset all the attributes so that you get a white light. However you sometimes might not want to move the fixture, and by holding down the Locate button, you get some more options.

- You can mask off some of the Locate settings (such as only turning the fixture on, but not changing its position or colour) by holding down Locate and pressing [Set Mask to Exclude All]. Then (still holding Locate) turn on the Attributes you want to change using the Attribute Bank buttons down the right hand side. Only the lit attributes will be changed by Locate. Pressing the Attribute Options button (just above Locate) will clear the mask.
- Option [Auto Reset Mask] sets the mask to be automatically reset to include everything each time Locate is pressed, or you can toggle the option to [Remember Mask] which will keep the mask setting you used last time.
- Option [Clear/Don't Clear Located Attributes] sets whether the attributes changed by the Locate function will be saved into any

cues you store. If the option is set to “Clear” then the Located attributes will not be stored in the Programmer unless you modify them using the wheels. This is useful if for example you want to program a cue which sets the position of fixtures, but does not turn them on. The Locate button will light up the fixtures for programming, but the lit state will not be stored in any cues you save.



To quickly locate without changing pan/tilt, hold Locate and press the Pan/Tilt (or Position) button, then release Locate.

To quickly locate pan/tilt only, hold Locate, press Attribute Options (just above Locate), then press Pan/Tilt (or Position), then release Locate.

4.1.3 Clearing selection

The Clear button (on the right of the numeric keypad) is used to remove all changes from the Programmer and deselect all fixtures. A quick press of the Clear button just clears everything, however if you hold down the Clear button, then more options are available.

- You can mask which attributes are to be cleared (for example, leaving the pan/tilt in the programmer but clearing everything else) by holding down Clear and pressing [Set Mask to Clear Nothing]. Then (still holding Clear) turn on the Attributes you want to change using the Attribute Bank buttons down the right hand side, or press [Set Mask] and use the softkeys. Only the lit attributes will be cleared. Pressing the Attribute Options button will clear the mask.
- [Clear Options] opens a submenu showing some further options (described below).
- [Clear All Fixtures/Selected Fixtures] sets whether all fixtures will be cleared from the programmer, or if only currently selected fixtures will be cleared. This is useful if you want to clear specific fixtures.
- [Individual Attributes] allows you to clear individual attributes from the Programmer. When you press the softkey, you are given a list of attributes in the Programmer – press the appropriate softkey to clear that attribute.

The options in the “Clear Options” submenu are:

- [Auto Reset Mask] sets the mask to be automatically reset to clear everything each time Clear is pressed, or you can toggle the option to [Remember Mask] which will keep the mask setting you used last time.
- [Leave/Zero Preset Fader Levels] is used to set whether latched fixtures are cleared (the fixture key profile can be set to “Latch” mode, which turns on the fixture dimmer channel when the fixture button is touched. See section 12.2.1 on page 157.)
- [Freeze current values] sets what happens to LTP (non-intensity) channels you have modified. If set to [Freeze Current Values] the channels remain as you set them. If set to [Release

To Playback Values] the channels will go back to how they are set in the current playback. For example: you have an active playback making some lights green, then you select the lights and change them to red. If you press Clear with this option set to [Freeze] then the lights remain red. If the option is [Release] the lights will go back to green.

You can use the Channel Grid window to selectively attributes from fixtures. See section 4.2.1 on page 62.

4.1.4 Changing attributes using the wheels

“Attributes” are the functions of the fixture, like pan, tilt, colour, dimmer, etc. You select which attributes you want to modify using the Attribute Bank buttons and set values using the wheels. The attributes available depend on the fixture type. Dimmer channels only have a dimmer attribute.

You can also select attributes by touching the IPCGBES buttons on the touch screen, and modify them using the Attributes workspace window; this is described in the next section.

Each attribute button controls several attributes, one on each wheel.

- 1> *With some fixtures selected, press the button for the attribute to be changed*
- 2> *Turn the wheels to set the attribute. The display above the wheels shows which attributes are being controlled, and the settings which are available scroll up and down as you turn the wheels.*

You can also touch the roller image on the screen to change the attributes up or down by one. For continuously variable controls like a dimmer, touching the roller will set the attribute to full or zero.

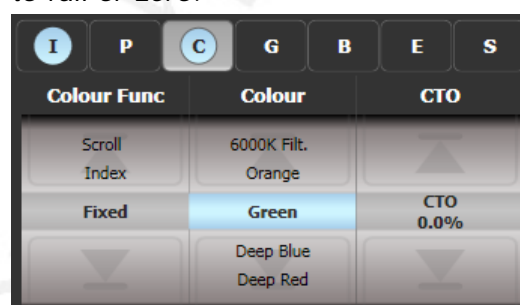

- 3> *Repeat from 1 to change other attributes of the selected fixtures.*

Some other things to know about attributes:

- If an attribute is in the programmer, it is highlighted (as shown with the “Green” setting in the screen picture above). This provides a quick way to see which attributes are in the programmer.
- You can also select the attribute to be changed from the softkeys by pressing the “Attribute Options” button.

- If the display above the wheels does not show the attribute when you press the button, that attribute is not available on the selected fixtures.
- If the wheel display shows a small arrow next to the legends, this means that there are further attributes to control. Press the Attribute button again to toggle through the attributes.

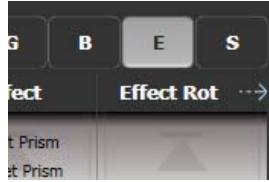

- The wheels operate in an “acceleration” mode. If you spin the wheel fast, the fixture changes in larger steps. If you move the wheel slowly, the fixture moves in its smallest increment.
- Holding down the Avo button while turning a wheel puts the wheel into “Fast” mode. When in this mode, a single rotation of the wheel changes the attribute you are controlling over its full range. For example, if while moving the Pan wheel you hold down Avo the fixture will make a complete pan movement between end stops in one rotation of the wheel.
- Some LED colour mixing fixtures have a Virtual Dimmer function (using the Intensity wheel) which offers intensity control by mastering the RGB levels when the fixture itself does not provide an intensity channel.

4.1.5 Setting attributes using the touch screen

For attributes with fixed values such as gobos and fixed colour wheels, the Attribute Editor window can be easier to work with than the wheels. It also offers a colour picker window for fixtures with RGB or CMY colour mixing.

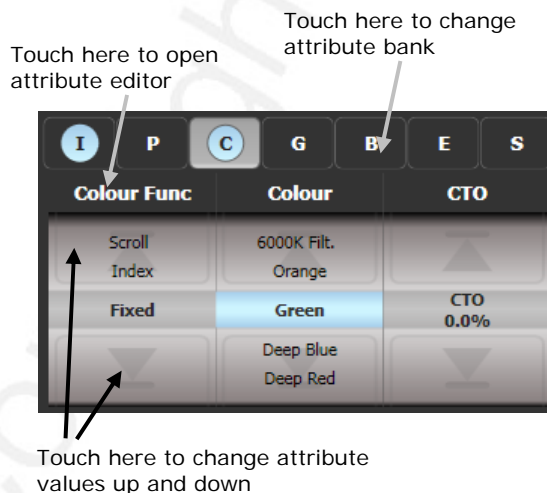

Press Window Open then [Open Workspace Window] then [Attribute Editor] to show it. As a shortcut you can also show it by touching the attribute name text just below the IPCGBES buttons (for example Colour Func in the above picture).

The buttons on the left of the window select the attribute to change.



The rest of the window contains buttons or controls to set the attribute value. For attributes such as gobos and fixed colours, a button is provided for each one, making selection a lot quicker than scrolling through on a wheel.

When you apply an attribute, the button turns blue to show that the attribute is in the programmer. If you touch the button again, the attribute will be removed from the programmer.

Touching the title of each attribute (such as “Colour Func”) expands the attribute to the full window, displaying more buttons.

For fixtures which are capable of colour mixing, you can select a colour from an onscreen palette of colours. The slider on the right hand side sets the intensity.

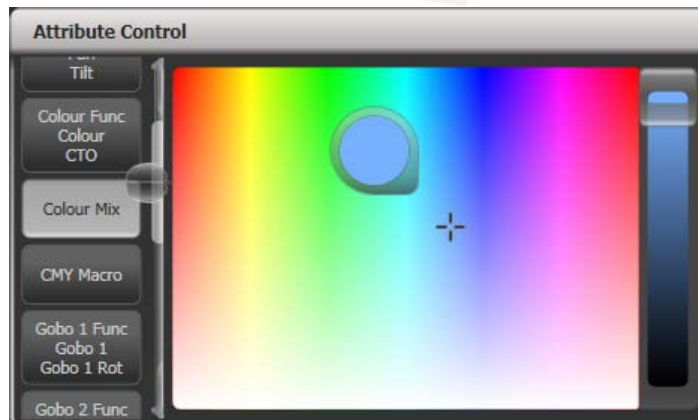

For variable attributes like Dimmer, holding down the button will display a horizontal slider bar. You can then move your finger left or right to change the value.



Active fixtures such as media servers will display a thumbnail of the media clip in the button. The media server must support CIP and be patched as an active fixture.

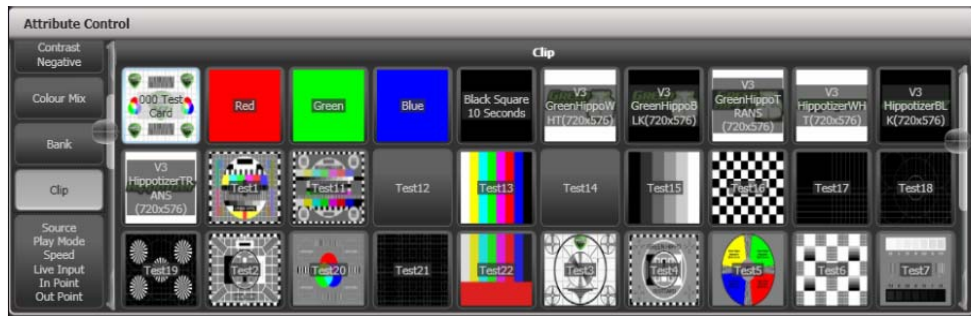

Fixtures which support keystoneing or blades/shutters can be controlled graphically in the attribute window. Select and drag the corners or sides of the image to control the fixture.



Updated personality files may be required to support the keystone/blade functions.

4.1.6 Setting attributes from the softkeys

You can directly enter a numeric value for the attributes which are live on the wheels. You must be at the main Program menu to do this (keep pressing Exit until the vertical menu bar shows "Program Menu").

Type a number on the numeric keypad then press one of the softkeys to set the value to the fixture. The Softkey legend will show what effect your value is going to have (such as [Gobo 5], or [Deep Blue]).



For attributes displayed in percent, such as Dimmer, or Colour Mix, you enter a value from 0-100 to set the percentage output. For attributes where the output is divided up into ranges, such as colour wheels, you enter the index of the range you want. For example to select the 3rd colour (as displayed in the list above the wheel) you would enter 3.

4.1.7 Selecting fixtures and dimmers by number (Channel)

In some situations, for example when programming lots of dimmers, it can be easier to type in the dimmer channels you want to program. The Channel menu allows you to do this for dimmers or fixtures. To access the Channel menu, press the Channel button on the top left of the numeric keypad. You can also simply start typing numbers on the keypad, when you press Thro, And or @ (functions of the arrow buttons below the numeric keypad) then the Channel menu will be shown.

Fixtures may be selected by User Number, Handle Number or DMX Address, as set by the option on Softkey A.

For Through, And and @ you can either use the softkeys or the grey arrow buttons below the numeric keypad.

When using the Channel menu it is helpful to latch it by pressing the Menu Latch button.

- To select a fixture, type the number and press Enter.
- To select more than one fixture, press the [And] softkey between each number. For example 1 And 2 And 5 Enter will select 1, 2, 5.
- To select a range of fixtures, press [Through]. For example 1 Through 8 Enter will select 1-8.
- To miss out fixtures in a range, use [Not], for example 1 Through 4 Not 3 Enter will select 1, 2, and 4.
- The @ softkey sets a dimmer level to the selected fixtures, for example 1 Through 8 @ 5 Enter will set 1-8 at 50%. (You can choose whether 50% is entered as "5" or "50" in the User Settings – see section 12.3.3 on page 160). When you press @ there are softkey options for Full, Off and +/- (increase or decrease brightness).
- You can work with Groups using the Group button, for example Group 1 And Group 2 Not 5 Enter will select all fixtures in group 1 and group 2 except for fixture 5.
- You can use the Locate button instead of Enter, to select fixtures and locate them. For example 1 Through 4 Locate will select fixtures 1 to 4 and locate them.

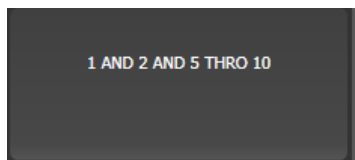

- When entering a command, the command line is shown on the display. You can go back using the grey ← button and you can abandon the line using the grey → button.
- The AND, THRO and @ functions are also provided on the arrow buttons as printed next to the buttons.

4.1.8 Selecting using a pattern

When programming you will often want to select patterns of fixtures. Rather than having to individually select and deselect fixtures, Titan Mobile has an easy way of selecting odd then even fixtures in a range of fixtures, or it can, for example, select every 4th fixture.

- 1> *Select some fixtures.*
- 2> *Press the white "All" button (below the Next Time button to the right of the wheels).*
- 3> *Select a pattern from the softkeys. Your selection is modified so you will only be controlling, say, the odd fixtures.*



- 4> *Press the white "Next" button to change the selection to the next stage of the pattern.*
- 5> *To end the pattern selection, press All twice.*

- For example, if you are programming a chase using 16 fixtures and you want every 4th fixture to do the same thing, you just select the 16 fixtures, then press All, then D [1 in 4]. You will see that the 1st, 5th, 9th and 13th fixtures are now selected, and you can create the look for those fixtures. Then press Next, and the 2nd, 6th, 10th and 14th fixtures will be selected ready for programming. After you have programmed the fourth set of fixtures, the pattern will go back to the first position again, until you press All twice to end.

- You can enter your own patterns using the numeric keypad and softkeys, for example "2" A [In] "6".

4.1.9 Selecting fixtures which are in a palette or playback

To select fixtures which are controlled by a particular palette or playback use the Select If function.

To select fixtures used in a playback or palette, press Select If then the palette or playback button.

You can also use Select If with the @ and Through buttons on the numeric keypad to select fixtures set to a particular intensity.

@X: fixtures set to intensity X

@ Through X: fixtures with intensity 0 – X

@ X Through: fixtures with intensity X – Full

@ X Through Y: fixtures with intensity between X and Y

@@: fixtures with intensity above 0.

Intensity levels may be input as 0-9 or 00-99 depending on the User Setting [Channel Levels Set In].

4.1.10 Attribute groups – IPCGBES-FX

To make life a bit simpler, the console groups together attributes which have similar effects, using the letters IPCGBES-FX.

I-Intensity (dimmer, strobe shutter)

P-Position (pan, tilt)

C-Colour (colour wheel, CMY mixing)

G-Gobo (gobo wheels, gobo rotate, gobo position)

B-Beam (iris, focus, zoom, beam shaper)

E-Effects (prism)

S-Special (motor speeds)

FX-Shapes, pixel mapper

These groups are used to select which attributes you want to work with in many of the functions on the console, particularly when you are "masking off" certain attributes from being saved.

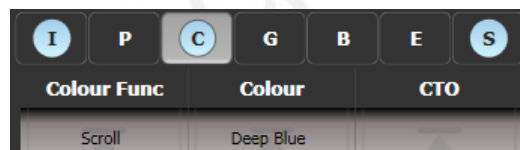

Above the attributes roller on the screen, the console shows you which attribute group you are currently changing (the grey box). The Attribute Group is also highlighted in blue if the programmer contains any of those attributes. For example in the image above we are currently changing Colour attributes, but Intensity and Special attributes have also been modified.

4.1.11 Using fixture groups

You can create groups of fixtures or dimmer channels, which can then be quickly selected together by touching a group button (shown in the Groups window) or typing the group number. You can, for

example, make a group for each type of fixture, or group by stage left / stage right, etc.

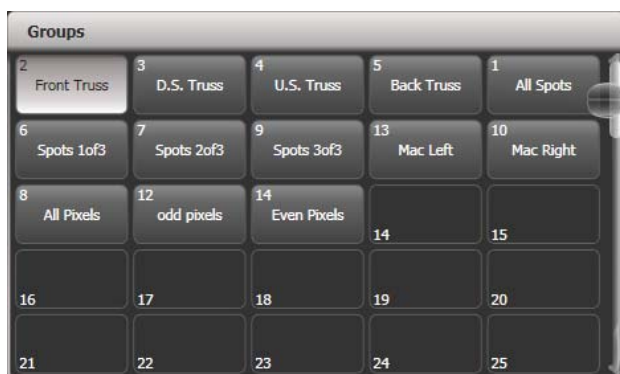

Auto Groups

When patching multiple fixtures, the console automatically creates groups for you. A fixture type group is created which contains all fixtures of the same type (for example, [All Mac 2000]). Another group is created each time you patch a quantity of fixtures (for example, [4 BB4].) This function can be turned off using [Auto Groups] in the User Settings.

If the Groups window is not visible, you can show it by pressing Window Open, Group (above numeric keys).

-
- 1> Select the fixtures/dimmers you want in the group (the order in which you select them will also be stored in the group).
 - 2> Press the grey Group button (top right of the numeric keys).
 - 3> Press [Record Group]
 - 4> Use softkey A to enter a number for the group, or B [Provide a legend] to set a legend.
 - 5> Touch an empty Group button where you want to store the group, or press C [Store] to store as a numbered group.
 - 6> Press Clear then repeat from 1 to store other groups.
-

- You can also press the Avo button and the Group button to go directly to the Record Group menu, or touch the button twice to use Quick Record – on the first touch the button will turn red with a +, on the second touch the group will be recorded.



- To select all the fixtures/dimmers in a group, just press the button for the group.
- The order in which you originally selected the fixtures when creating the group is also stored. This takes effect when you use the last fixture – next fixture functions described in the next section, and when you use Shapes, Fan mode and Fixture Overlap functions. You can change this later, see the next section.
- You can also recall a group by its number:

-
- 1> Press the grey Group button.
 - 2> Type in the number of the group you want to recall.

3> Press [Recall Group].

- The Group button also gives you facilities on the softkeys to edit and delete groups.

4.1.12 Fixture Order and Fixture Layout in groups

Fixtures in a group are stored with a selection order, which is used with Shapes, Fan, and Overlap. You can also store a 2D position layout for fixtures, giving the actual physical location of fixtures for use with the Pixel Mapper effects.

To change fixture order:

1> Press [Edit Times].

2> Select the group you want to edit.

3> Press [Fixture Order].

The fixtures in the group will be shown numbered in the fixtures window.



To change the order, select [Auto Increment] to On, then select the fixtures in the order you want. If you press a fixture twice, it will show an X indicating that it is not part of the sequence.

To change fixture layout:

1> Press [Edit Times]

2> Select the group you want to edit.

3> Press [Edit Layout]. The Layout Editor window will open.

Initially fixtures will be all in a row. You can reposition the fixtures anywhere on the screen by dragging them. Or press a fixture to select then use the wheels to move it around the grid. You can resize the grid by dragging the bottom or right sides.

The [Arrange Fixtures] command will automatically place the fixtures in a rectangular block, you specify the number of rows (Height) and columns (Width).

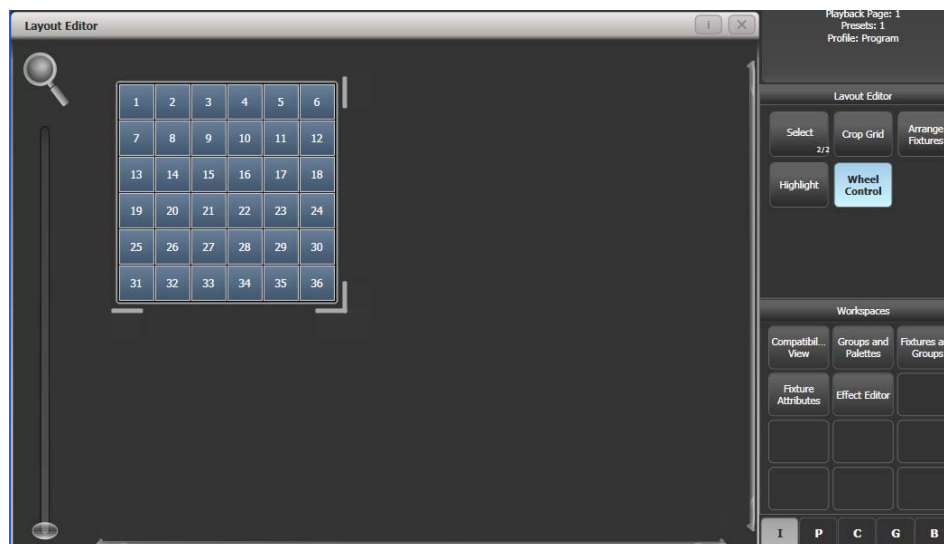

4.1.13 Stepping through selected fixtures one at a time

If you have selected a range of fixtures, or a group, the console has functions to step through the selected fixtures one at a time. This can make it easier to program a range of fixtures because you don't have to select each one manually.

This mode uses the Prev/Next/All/Highlight buttons to the right of the Go button.

-
- 1> *Select a range of fixtures or a group.*
 - 2> *The Prev and Next buttons will select the fixtures in the range one at a time (in the order you selected them).*
 - 3> *The ALL button will select all fixtures in the programmer (everything which has been selected since Clear was last pressed).*
-

- The Highlight function can be used to highlight the output of the selected fixture (make it brighter onstage), see the next section.

4.1.14 Highlighting the selected fixture with Prev/Next

When stepping through a fixture selection using the Prev/Next/All buttons, you can highlight the selected fixture on stage. This makes it very easy to see which fixture you are controlling. The other fixtures in the selection go to a dimmed "lowlight" level.

- Press the HiLight button to enable highlight mode. Press HiLight again to disable. When you are in highlight mode, the highlighted attribute is overridden and any changes you make to it are not stored in the programmer (so if the highlight uses intensity, you cannot change the intensity of the fixture).
- You can change the levels used for Highlight/Lowlight by pressing Record, then pressing HiLight, [Store Highlight State] or [Store Lowlight State].

4.1.15 Flash selected fixtures to full

It can be useful when programming to see on stage which fixtures you have got selected. Press the Flash Full button to do this (Avo +

Page+1 button). You may also want to turn off selected fixtures, the Flash Out button does this.

4.1.16 Turn off unselected fixtures

To turn off all unselected fixtures use the Remainder Dim function by pressing Rem Dim (Avo+All). The zero intensity is placed in the programmer and will be recorded into any cue. This is useful when removing fixtures from cues.

4.1.17 Align fixtures

You can copy attributes from one fixture to another using the Align Fixtures function. This is very useful, for example, if you've accidentally left a fixture out of a cue you can copy settings from its neighbour.

-
- 1> *Select the fixtures you want to Align.*
 - 2> *At the top level menu press Fixture Tools/Menu Latch (just below the G softkey) then [Align Fixtures].*
 - 3> *Set the mask to include the attribute groups you want to copy (using the Attribute Bank buttons on the right of the console, or the softkeys set options for exclude and include all attributes).*
 - 4> *Touch the select button of the fixture you want to copy the settings from.*
-

4.1.18 Flip

Moving head fixtures can point at the same stage position from two possible yoke positions. Sometimes to get the fixture moving the same as other fixtures, you need to swap to the opposite yoke position and the Flip function lets you do that.

-
- 1> *Select the fixtures you want to Flip.*
 - 2> *At the top level menu press Menu Latch then C [Flip Pan and Tilt].*
-



The settings used for Flip are defined in the fixture personality. If Flip doesn't work you may need to update to the latest personality.

4.1.19 Fan mode

Fan mode automatically spreads out the values on a selected range of fixtures. If used on pan and tilt, the result is spreading out "rays" of light beams. The first and last fixtures of the range are affected most, and the central fixtures are affected least. The amount of fan can be set using the attribute wheels.

As with shapes, the order in which you select the fixtures sets how the fan effect works. The fixtures you select first and last will be the ones which change most. If you use a group to select the fixtures, the order you selected the fixtures when you recorded the group is used.

The fan effect, while normally used on pan or tilt attributes, can be applied to any attribute.

-
- 1> *Select the fixtures you want to fan.*
 - 2> *Press the Fan button.*
 - 3> *Select the attribute you want to Fan using the attribute bank buttons.*
 - 4> *Set the amount of fan using the attribute wheels.*
 - 5> *Turn off Fan by pressing the Fan button again when you have finished.*
-

If you have selected fixtures from multiple groups, you can choose whether the fan effect works with or ignores the groups. For example if you have 12 fixtures across the stage in 3 groups of 4, you may want a fan of light beams spread evenly across the stage, or you may want 3 groups of separately fanned light beams.

By holding down the Fan button you can select:

- [Ignore groups] All fixtures are fanned as one large group
- [Fan group as fixture] All fixtures in a group take on the same value.
- [Fan Within group] Fan runs across individual fixtures in each group.

Holding down the Fan button also allows you to select the Curve used for the fan. The different curves allow you to obtain different fan effects.

Fan mode needs to be used on at least 4 fixtures to give good effects. If you have an odd number of fixtures, the central fixture will not change in fan mode.

Press the Fan button again to leave Fan mode. Any effects you have set will remain in the programmer.



It's fairly easy to accidentally leave Fan mode turned on and be very confused about why the wheels aren't working properly, so turn it off as soon as you have completed the effect. To avoid this there is a User Setting 'Press and hold Fan'. If enabled, you have to hold down the Fan button to enable Fan mode. See section 12.3.3 on page 160.

Fan Curves

You can select different curves to use when in Fan mode. Hold down the Fan button and select [Curve], the options are:

- Line: Traditional fan, the first and last selected fixture are affected equally in opposite directions, the midpoint remains

unchanged. This remains most useful for pan.

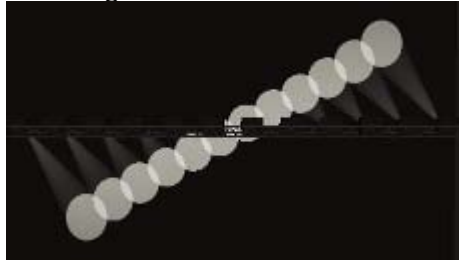

- Pull Middle - The first and last selected fixture remain at the current value, the midpoint is affected most. This is useful for colour mixing, tilt and dimmer.

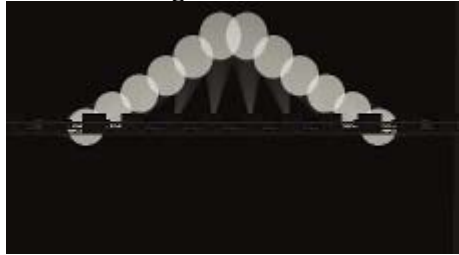

- Pull Ends - The first and last selected fixture are affected most, the midpoint is unchanged. This is useful for colour mixing, tilt and dimmer.

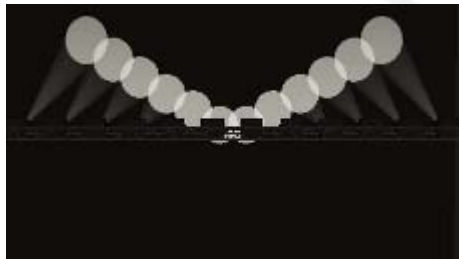

- Arrow - The first and last selected fixture are affected equally to the midpoint fixture but in the opposite direction. This is useful for colour mixing, tilt and dimmer

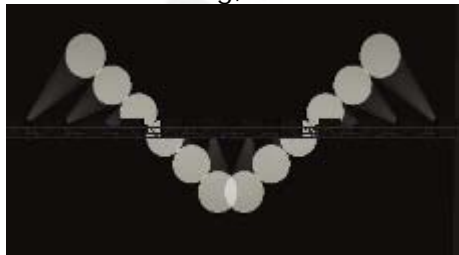

Fan Parts

When using the Fan function you can split the fan into a number of groups. Select all the fixtures, hold down Fan and type a number on the numeric keypad. The Fan will divide into that number of parts, for example:

Normal (1):



2:

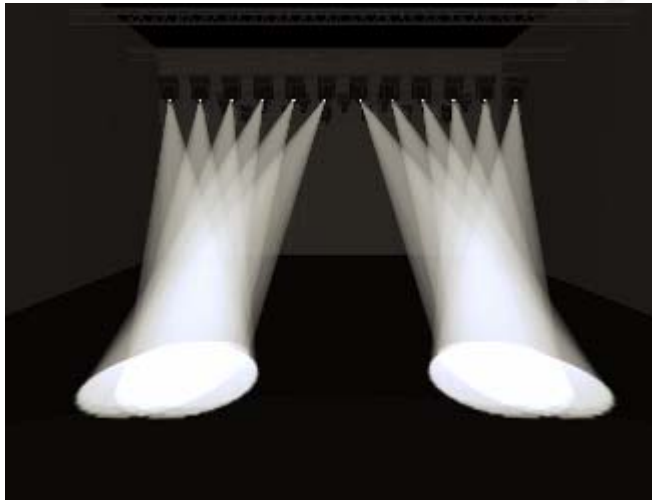

3:

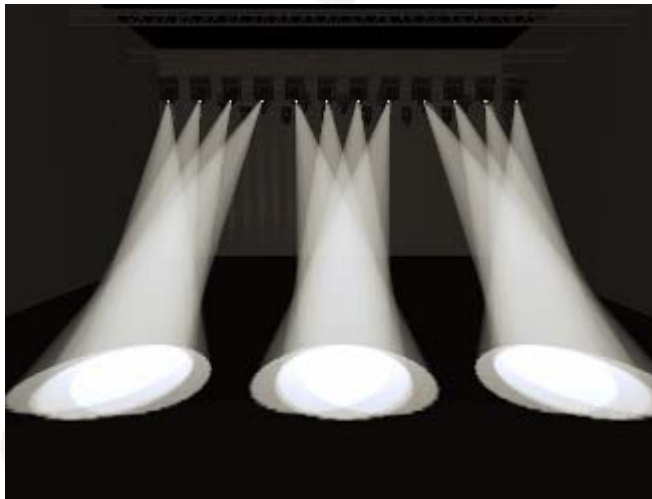

4.2 Viewing and using numerical values

4.2.1 The Channel Grid window

It can sometimes be useful to display and edit exactly what each fixture is doing. The Channel Grid window allows you do to that. Display it by pressing Window Open then [Show workspace window] then [Channel Grid].

Channel Grid												
	Number	Dimmer	Shutter	Shutter Func	Pan	Tilt	Colour Func	Colour	CTC	CTO	Cyan	Red
ClrSp 1200	1	-	Closed		54.89	40.68	Fixed	Open		-	-	
ClrSp 1200	2	-	Closed		45.78	39.77	Fixed	Open		-	-	
ClrSp 1200	3	-	Closed		59.67	39.88	Fixed	Open		-	-	
ClrSp 1200	4	-	Closed		60.77	40.51	Fixed	Open		-	-	
ClrSp 1200	5	-	Closed		53.30	45.85	Fixed	Open		-	-	
ClrSp 1200	6	-	Closed		51.78	47.06	Fixed	Open		-	-	
ClrSp 1200	7	-	Closed		48.32	47.26	Fixed	Open		-	-	

The window can be set to different modes using the context buttons to the left of the menu. The modes are:

- Playbacks: shows which playback is controlling each attribute of each fixture
- Levels: shows the output levels of each attribute. These may be shown numerically or as range names.
- Palettes: shows which palettes are allocated to fixture attributes
- Shapes: shows which shapes are running on fixtures
- Output/Programmer: switches between the attributes on the console output, and the attributes currently in the programmer
- Highlight off/changes: if set to [Highlight changes] then changing attributes will be highlighted.
- Narrow/Wide columns: changes the column width on the screen.

You can **select** fixtures by touching the fixture names on the left of the screen, or if you select any fixture values, the appropriate fixture will automatically be selected.

You can **clear** attributes in the channel grid by selecting them (touch or touch and drag to select multiple attributes). Then press Clear.

You can **edit values** by selecting one or more values in the grid, then modify the values using the wheels, or type a new value on the numeric keypad and press Enter.

4.3 Advanced options

4.3.1 The Latch Menu button

When the console is at the top level menu, this button opens the Moving Light Actions menu which contains options to Locate Fixture (same as the Locate button) and to run Macros on fixtures such as

Lamp On, Lamp Off, Reset etc. The Align Fixtures and Flip functions as described above are also in this menu.

If another menu is loaded, the button latches the current menu. Press Exit to get back to the top menu so that you can access the Moving Light menu.

4.3.2 Lamping fixtures on and off

Many fixtures have a control channel which allows you to perform functions like lamp on, lamp off, fixture reset, and so on. This can be useful to shut down fixture lamps at the end of a show while the fans continue to run, or to reset a fixture which has gone haywire.

The console allows you to access these functions using Fixture Macros (not the same as keypress macros).

-
- 1> *Keep pressing Exit until you are at the top level menu.*
 - 2> *Select the fixtures you wish to control. Some macros will not work across groups of fixtures from different manufacturers.*
 - 3> *Press Fixture Tools/Menu Latch then [Macros].*
 - 4> *The softkeys show a list of the functions available. Press the one you want to action.*
-

- Some macros involve timed sequences and can take up to 30 seconds to execute.

Copyright Avolites 2011

5. Palettes

When programming a show you will find that you frequently use certain positions, colours, etc. The console lets you store these settings so you can recall them at the touch of a button rather than having to find them on the wheels every time. This is very useful when busking a show.

When you use a palette to record a cue, the console stores a reference to the palette, rather than the actual value. This means that if you program your cues using palettes, you can easily change all the positions in your show just by reprogramming a few palette entries rather than having to reprogram all the cues. This is handy if you are touring and have to cope with different stages or truss heights every show.

Palettes are stored and selected using buttons on the touch screen, grouped into different windows for Colours, Positions and Gobos & Beams. You can set a legend for each button so that you know what you're going to get.



If the Colours, Positions, Gobos & Beams windows are not shown, press Window Open then [Open Workspace Window] then [Groups and Palettes] to show all three windows.

5.1 Creating palettes

5.1.1 Which attributes are stored in palettes

Although each palette entry can store all attributes of a fixture, it's easier to operate the console if you create some palettes which only set positions, some for colour, some for gobo and so on. The console helps you with this by providing separate windows for Colour palettes, Position palettes, and Gobo/Beam palettes.

When you store a palette, it will only contain what's in the programmer (the attributes you have changed since you last pressed Clear). For example to create a colour palette you would just set the colour, and not change any other attribute.

If the programmer contains more than one attribute, you can set a mask to restrict which fixture attributes will be stored in the palette.

Palettes may be either Shared or Normal. Shared palettes are used where the same value is set for all fixtures of the same type – for example when setting colours, the "Red" palette would set the same colour values for "Red" to all MAC 2000 fixtures. Normal palettes are used when each fixture requires its own value - for example when programming positions, each fixture will have a different setting.

5.1.2 Storing a palette

This is how you save a palette value:

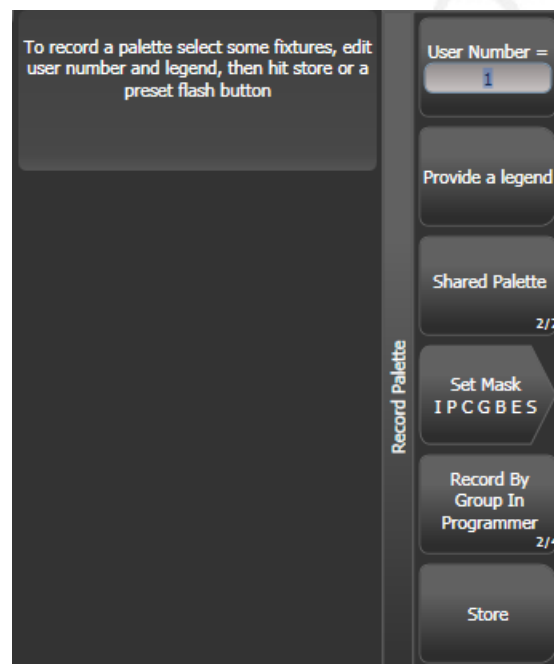

- 1> Press Clear to clear the programmer.
- 2> Select the fixtures for which you want to store palette values.
- 3> Using the attribute buttons and wheels, set the attributes you want in the palette entry. You can store any or all attributes of a fixture in each palette entry.
- 4> Press the Record Palette button
- 5> Set the palette Mask – this sets which attributes will be recorded in the palette. Select attributes using the Attribute Bank buttons – anything lit up will be saved. [Set Mask] and [Record by] softkeys also control the Mask (see below).

6> Press an unused Palette button to store the palette. Or enter a palette number and press [Store]

- The console will automatically set the palette as Shared or Normal (by checking if the values to be stored are the same across all fixtures of the same type). You can override the setting by pressing softkey C.
- [Set Mask] allows you to specify which attribute groups will be included in the palette. You can also use the grey Attribute Bank buttons on the right hand edge of the console to set the mask.
An attribute group is included when the softkey is inverted (like the Colour group in the picture) and when the LED is lit on the Attribute Bank button. If you use Quick Record (see next section) the mask is automatically set by the workspace window you save the palette in – Positions only includes P, Colours only C and Beams includes IGBES. If you use the Record Palette button then you need to set the mask manually.
- Press the Attribute Options button to toggle all mask groups between Include and Exclude.

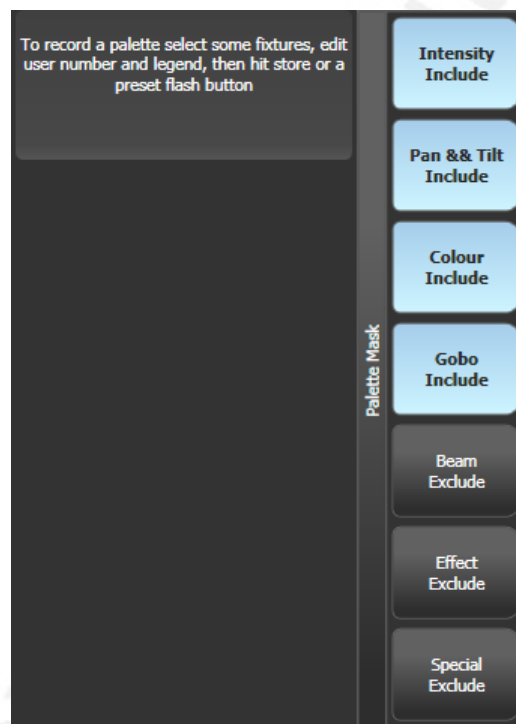

- [Record By...] allows you to control how the mask is used when saving the palette. The options are:
 [Channel in programmer] records only channels which are in the programmer (which have been changed)
 [Group in programmer] records all channels in any attribute group which has one or more channels in the programmer. For example if Cyan is in the programmer, all colour channel settings will be recorded even if not in the programmer.
 [Group in mask] records everything included by the mask set on the attribute buttons
 [Mixed] records by attribute group for Position and Colour but by channel for all other controls.

- You can set a legend for the palette while you are saving it using [Provide a legend]. See section 5.1.4 for how to change the palette legend.
- If you select a Palette button which is already used, the console offers you options to [Cancel], [Replace] or [Merge] the existing palette. [Replace] will erase the palette and save only the latest changes you have made. [Merge] will combine your changes with the palette. This allows you to add settings for additional types of fixtures to a shared palette. Pressing the palette button again will automatically merge.

5.1.3 Quick record

The palette windows allow you to quickly record a new palette. Just touch the button where you want to record – the button will turn red with a + sign. At this point you can enter a legend for the new palette or change mask settings. A second press on the button will save the palette.



- When using Quick Record, the palette mask is automatically set to match the window, so if you touch a button in the Position window, the mask will be set to only store position attributes. This does not happen if you use the Record Palette button.

Quick record also works for groups, workspaces and the playback window.

5.1.4 Setting legends for palettes

You can enter a legend for each palette which is displayed on the palette touch button.

-
- 1> Press [Set Legend] at the top level menu.
 - 2> Press the palette button for the palette you want to legend.
 - 3> Type the legend on the keyboard.
 - 4> Press Enter when you have finished.
-

- On touch buttons, the palette number is shown top left. The IPCGBES attribute groups contained in the palette are displayed below your legend, so for example Position palettes will show a P, colour palettes a C and so on. In the top right corner is shown N for a Normal palette or S for Shared.

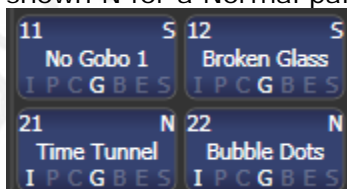

You can create a picture legend for your palette which could for example represent the colour or gobo it will create. After pressing [Set Legend] and the palette button, press [Picture]. The picture editor will open.

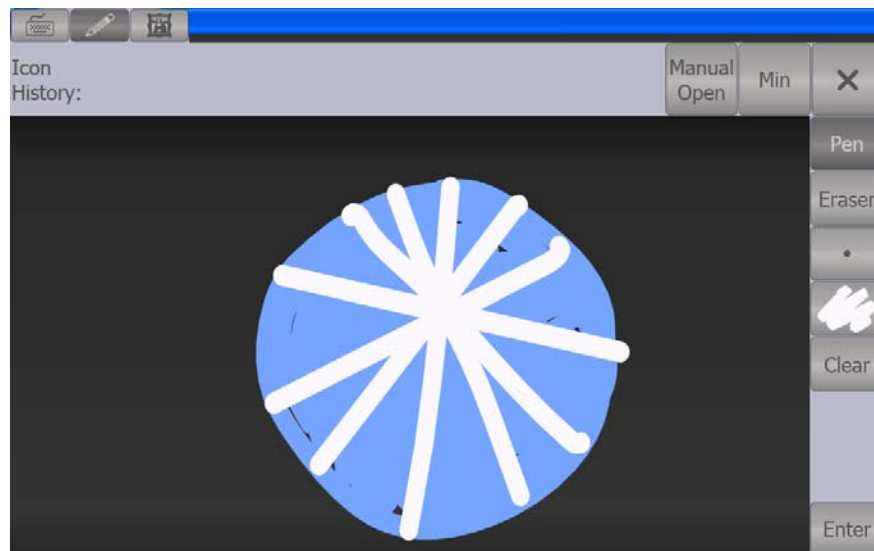

The tab buttons on the top left allow you to select Keyboard entry (legend reverts to text), Draw or Library. On the right you can choose Pen or Eraser, set the pen/eraser size, set the colour (white in the above picture), clear the whole picture, and Enter the legend. The Min button top left reduces the editor to a smaller size.

If you select Library you can choose a picture from a wide range of pre-programmed pictures. The pictures are sorted into various folders which are listed on the left.



5.2 Recalling palettes

5.2.1 Recalling a palette value

To recall a palette value from a button, this is what you do:

- 1> *Select the fixtures to be changed. Shared palettes can be set to any fixture of the same type. Normal palettes will set individual values to each fixture.*
- 2> *Press the Palette button you want to recall. The palette will be set to the selected fixtures.*

- You can make palettes fade over a time when you recall them, see section 5.5.1 below.

You can also recall a palette by its number by typing the number on the numeric keypad.

-
- 1> *Select some fixtures*
 - 2> *Press the Palette button above the numeric keypad*
 - 3> *Type in the number of the palette you want to recall.*
 - 4> *Press Enter or [Apply Palette]*
-

- The [Apply Palette] softkey shows the legend of the palette which will be applied.

5.2.2 Palette pages

Each of the palette windows can either display pages of palettes, with page buttons on the left, or a continuous scrolling window of palettes. To change between pages and scrolling, touch the Pages Show/Hide button in the context button area to the left of the menu buttons. using the page buttons to the left of the palette buttons.

- You can recall a palette from any page using its number as described in the previous section.

5.2.3 Quick palettes with no fixtures selected

If you press a palette button when no fixtures are selected, the palette will be set to all the fixtures the palette applies to. This is called a Quick Palette. For example if you've got some colour palettes programmed for your MAC 2000's, pressing one of the palettes when no MAC 2000's are selected will set the colour to all the MAC 2000's.

5.2.4 Setting palettes to all fixtures in a playback

You can apply a palette to all fixtures in a particular playback. Hold the palette button and press the select button of the playback which the palette is to apply to.

5.3 Editing palettes

5.3.1 Viewing and editing the content of palettes

You can view the contents of a palette in the Palette View window. This lists all fixtures in the palette and the attribute values stored for them.

Press Window Open, then the palette button. The Palette View window will open.

Palette - Palette 76											
	Number	Order	Colour 1 Func	Colour 1	CTO	Cyan	Magenta	Yellow	Colour 2 Func	Colour 2	CMY Macro
BT Spot	113		Fixed	Open	0.0	0.0	0.0	0.0			Open
BT Spot	114		Fixed	Open	0.0	0.0	0.0	0.0			Open
BT Spot	115		Fixed	Open	0.0	100.0	0.0	0.0			Open
BT Spot	116		Fixed	Open	0.0	0.0	0.0	0.0			Open
BT Spot	117		Fixed	Open	0.0	100.0	0.0	0.0			Open
BT Spot	118		Fixed	Open	0.0	0.0	0.0	0.0			Open
ClrSp 1200	-		Fixed	Open	0.0	0.0	0.0	0.0			Open
Mac 2000W	-		Fixed	Open	0.0	100.0	0.0	0.0	Fixed	Open	

To edit an attribute value, touch/click on it in the window. The softkeys will give you a list of available settings for this attribute or you can type in a numerical value.

There is also a [Delete] button which allows you to remove the value from the attribute. This is the same as using the Off function.

5.3.2 Changing the content of palettes

To edit a palette entry, press the Update Palette button, select the palette to edit (this will automatically select the fixtures used in the palette), make the changes you want, then press the [Update Palette x] softkey to save the changes.

The Update Palette button also allows you to change the palette name and number.

You can also load the palette into some fixtures, modify the attributes and record the new information back on top of the existing palette entry. The console will give you options on the softkeys to Replace or Merge the palettes. If you select Merge, anything you haven't changed will not be affected, values you have changed or added will be amended.

- You can set the console to "Always Merge" (so it doesn't ask you) using option A of the User Settings (hold down the Avo button to set these). You can also press the palette button a second time to select the Merge option.
- You can add additional fixtures to a palette without affecting existing ones. For example, if you have colour palettes for Mac 600s, you can add colours for your Mac 500s without affecting any previously recorded values in the palette.
- You can remove attributes from palettes using the Off function, see section 7.3.5 on page 111.
- When editing a palette the state of the programmer will be preserved; when the modified palette is saved, your original programmer contents will be restored and the programmer will be left in the same state as when you started editing the palette.

5.3.3 Updating palettes used in a playback

If you need to quickly update a palette during a show, for example you fire a green cue and the Green palette used turns out to be not quite the right colour, the Update function lets you automatically update the palette used in the cue.

-
- 1> *With the cue fired, select the fixtures and change them to the settings you want to store (e.g. the right green colour).*
 - 2> *Press Update.*
 - 3> *The cues and palettes which can be updated are shown on the softkeys and all other buttons are greyed out.*
 - 4> *Press the palette button (for example, Green) twice to update that palette.*
-

- You can also select multiple palettes to be updated by highlighting them in the softkeys then pressing Enter to confirm.

5.4 Copying, moving and deleting palettes

5.4.1 Copying or moving a palette

Using the Copy button you can make a copy of an existing palette or move it to a new button. You can copy or move multiple palettes in one operation. You cannot link palette buttons.

Move is useful for tidying up the console.

-
- 1> *Press the Copy button.*
 - 2> *Select [Copy] or [Move]. Pressing the Copy/Move/Link button again will also toggle these options.*
 - 3> *Press the Select button of the palette you want to copy/move. You can select multiple palettes.*
 - 4> *Press the empty button where you want it to go.*
-

- The Menu Latch button latches the Copy/Move/Link menu, so you can keep copying, moving or linking things without having to keep pressing the Copy button. Press Exit to unlatch.
- [Retain Layout] or [Bunch Up] is used when copying a group of palettes with empty handles in the group – you can either keep the empty handles, or bunch up the used handles together.
- When in Copy mode, option [Copy Legends] can be changed to [Don't copy legends] so that the copied palettes are given default legends.
- When in Move mode, [Swap Items if Required] will attempt to reposition any existing handles which are in the way of the move. This is useful when rearranging buttons on a page which is nearly full.

5.4.2 Deleting palettes

You can delete a palette entry by pressing the Delete button, then pressing the palette select button to be deleted. Press the palette button again to confirm the deletion. You can delete a range of palettes in one go by running your finger along the buttons.

Other ways to delete a palette:

- Press the Palette button above the numeric keypad and use the [Delete] option in the [Palette Utilities] menu.
- Press Delete then [Palette], type the palette number, press Enter.

5.5 Timing palettes

5.5.1 Fading a palette

A timed palette is a very useful tool allowing easy "busking" of shows. When a palette is recalled in this way, a time is added and the palette fades in over that time.

-
- 1> *Select some fixtures*
 - 2> *Type in the fade time for the palette on the numeric keypad*
 - 3> *Press a palette button to recall the palette*
-

- You have to re-enter the time each time you recall a palette. To use the same fade every time, set a Master Time: Press Palette, [Master Time]. To disable Master Time set to 0.
- Palette fading can be very useful when recalling a palette live during a show, as you can smoothly move fixtures to a new position or change colour slowly (on colour mixing fixtures).
- Palettes applied with a fade time do not get put into the programmer, so will not be saved in any cues; don't use fade times when programming. This is to ensure that when used in a live situation, the next cue will override the palette and play back as intended.

5.5.2 Fixture overlap when recalling palettes

You can set a Fixture Overlap when recalling a palette, which means that the palette will be applied in sequence to each fixture in the group. This is a very quick way to busk some amazing effects. Fixture Overlap=100% means that all fixtures will change together. Fixture Overlap=0% means that each fixture must complete its fade before the next will start its fade.

-
- 1> *Type in the overlap time for the palette on the numeric keypad*
 - 2> *Press [Set Overlap]*
 - 3> *Type in the fade time if fade is also required*
 - 4> *Press a palette button to recall the palette*
-

- You have to re-enter the overlap each time you recall a palette. To use the same overlap every time, set a Master Overlap: Press Palette, [Master Overlap]. To disable Master Overlap set to 100%.

5.5.3 Master Time for palettes

Option [Master Time] on the Palette menu (press the grey Palette button above the numeric keypad) allows you to set a default fade time. This fade time will be used for all palettes unless you manually type in a different time. This can be useful when "busking" a show with palettes.

The [Master Overlap] option similarly sets the default Overlap for palette recall.



You can create macro buttons to set different palette fade times. Press Macro, Record, press a button to store your macro on. Then press Palette, [Master Time], 3 (for 3 sec), Exit, Macro.

Repeat these steps to create a Palette Snap button (0 sec), or a 1 sec fade button, and so on.

Copyright Avolites 2017

6. Shapes and Pixel Mapper effects

The Shape Generator in Titan Mobile (sometimes known as an Effects Generator on other consoles) allows you to quickly create exciting light shows using lots of movement and changes, with the minimum of programming.

The Pixel Mapper is used to generate animated textures using the colour or intensity of a group of fixtures (often LED battens, starcloths or LED web type fixtures). When viewed at a distance the effect becomes clearly visible.

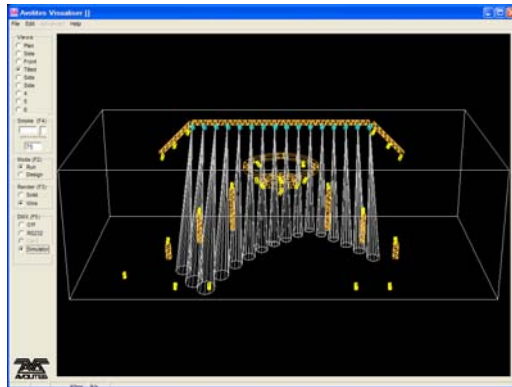

A shape is simply an automatic sequence of values which can be applied to any attribute of a fixture. A circle shape, for example, applied to the pan and tilt attributes, would cause the fixture to move its beam around in a circular pattern. You can set the centre point of the circle, the size of the circle and the speed of the circle movement.

In addition to position shapes, there are a large number of other shapes available in Titan Mobile. The shapes are defined for a particular attribute such as colour, dimmer, focus and so on. Some shapes will not work with some fixtures; focus shapes, for example, can produce nice "focus pull" effects on fixtures which have DMX focusing, but will do nothing on fixtures which don't have focusing.

A further category of shapes is the Block Shape. This type of shape blocks out other shapes, preventing them from running. For example, if some fixtures are running a Circle shape, and then a playback is fired which has a Block Pan/Tilt shape on some of the fixtures, those fixtures will stop running the circle shape. This can be very useful to modify playbacks at showtime when used with the playback priority feature (see section 7.6.5 on page 117).

When you use a shape with more than one fixture, you can choose to either apply the shape identically to all the fixtures, or offset them so that the shape runs along the fixtures creating "wave" or "ballyhoo" type effects. This is called the *Phase* of the shape.

6.1 Creating effects

6.1.1 Creating a shape

To create a shape you simply pick the attribute of the shape from a list on the softkeys, then choose the shape you want from the Shapes window. Shapes are organised using the IPCGBES attribute groups, so you can pick from a list of Dimmer shapes, or a list of Pan/Tilt shapes, or Colour shapes, and so on. You can also pick from a list of All Shapes.



When you create a shape, it will be applied to all selected fixtures.

-
- 1> Select the fixtures the shape is to be applied to.
 - 2> At the main menu press [Shapes and Effects] then [Shape Generator].
 - 3> Press [Create] to start a new shape.
 - 4> Press a softkey to select the attribute type to use in the shape or press [All shapes] for a full list.
 - 5> Press a softkey to select a shape, or touch the desired shape in the Shapes window. You can type a search word on the keyboard to search for a particular shape.
 - 6> The shape will be applied to all selected fixtures.
-

- If you open the Shapes window, it will remain open for instant selection of shapes (you don't need to select [Shape Generator]). The window will only show shapes which are possible on the selected fixtures. Pressing attribute buttons will filter the Shapes window to show only shapes for that attribute. Press the Dimmer attribute button to show all shapes.



- Shapes are based on the current settings of the fixture, so a position circle would move around the current pan-tilt position of the fixture.
- You can change the base value of a shape (e.g. the centre of a circle) by changing the attributes using the wheels in the usual way. You can reduce the Size to zero (see next section) to help you see what the base value actually is.
- You can run more than one shape at a time by repeating the above procedure. You can run several shapes on one fixture and the output will combine in interesting ways.
- Press [Shapes and Effects], [Shape Generator] then [Edit] to show what shapes are running.
- If you apply the same shape to two different groups of fixtures, the shape will appear twice on the shape list. You can edit the two shapes separately to give different directions, speeds etc (see later)
- Each shape is designed to work on a particular attribute. Obviously if the fixtures don't have the attribute, you will not see any effect if you use the shape.
- Each shape has a default size and speed setting (defined in the shape file).



When using a Rainbow colour shape, to get the full range of colours you need to set the CMY or RGB attributes to 50%.

6.1.2 Changing size and speed of a shape

It is easy to change the size and speed of a shape after it has first been created. If the display above the wheels is showing Spread and Offset rather than Size/Speed, press softkey E to select [Adjust Speed, Size and Phase] .

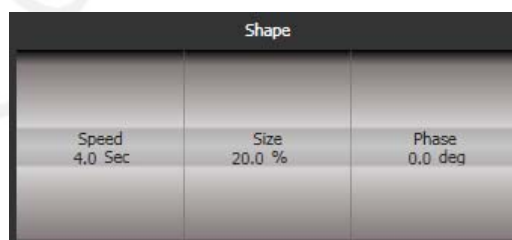

-
- 1> Control the speed of the shape using the left hand wheel.
 - 2> Control the size of the shape using the middle wheel.
 - 3> The size and speed is shown above the wheels on the display.
-

Other things to know about size and speed of shapes:

-
- If you have more than one shape running, the controls operate on the most recent one. You can edit the parameters of any shape that's running using the Edit Shape function, see section 6.2.1.
- The minimum size is zero. This will "hide" the shape, and the fixture will resume its previous settings. The shape is, however, still active.

6.1.3 Changing the phase of a shape across multiple fixtures

Shapes get more interesting (and look more impressive) when you apply them to multiple fixtures. You can control how a shape is phased across several fixtures. You can also control Spread, which is a different way of selecting the same thing.

The sequence of the shape across the fixtures is controlled by the order in which you selected the fixtures when you created the shape..

-
- 1> Press softkey E to select [Adjust Phase, Spread and Offset]
 - 2> Control the phase of the shape using the left hand wheel, or to set in terms of Spread, use the middle wheel.
-

Phase=0 deg

Phase=22.5 deg (Spread=16 fixture)

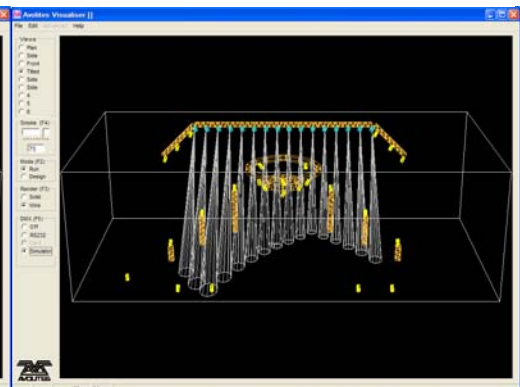
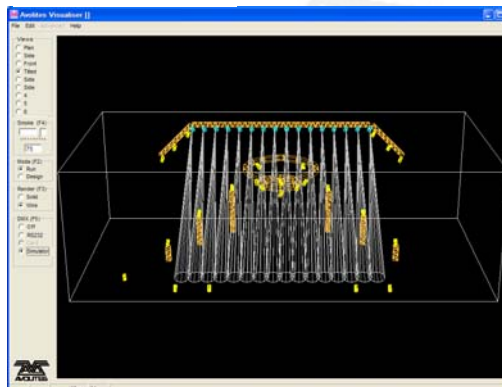

Phase=60 deg (Spread=6 fixture)

Phase=180 deg (Spread=2 fixture)

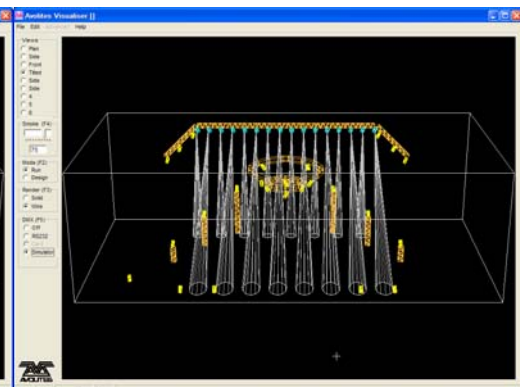
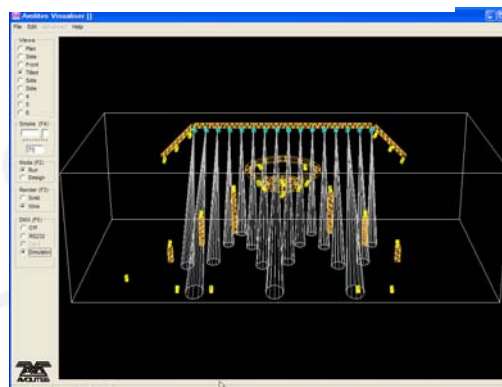

The display above the left hand wheel shows the phase in degrees. For example, 180 degrees repeats every 2 fixtures, 90 degrees repeats every 4 fixtures, 60 degrees repeats every 6 fixtures, and so on.

The Offset function allows you to set the starting phase of the shape, when more than one shape is running. For example, if you were running a Cyan shape and a Magenta shape to create a mix of colours, you would probably want to start them with Cyan at full and Magenta at zero to give the full range of colours. In this case you would set one of the shapes to have a Phase Offset of 180 degrees. Without the phase offset, both shapes would reach full at the same time.

6.1.4 Creating pixel mapper effects

The Pixel Mapper works on a group of fixtures, which you have set up using the Fixture Layout function. This tells the console where the fixtures are physically located on the stage. The console then maps the fixtures as pixels and uses them to output a 2D effect. See section 4.1.12 on page 56 for details of how to layout the fixtures.



At the end of this section (Section 6.4 on page 83) there are a number of step-by-step examples of creating effects with the pixel mapper.

You set up the Pixel Mapper as follows.

- 1> *Select the group of fixtures.*
- 2> *From the top level menu select [Shapes and Effects] then [Pixel Mapper]*
- 3> *Select [Create effect]. The Pixel Mapper Editor will open with a blank background. You can overlay your fixture layout on the window, to help you see where your fixtures are, by clicking on the [Fixture Overlay 50/50] context menu button.*

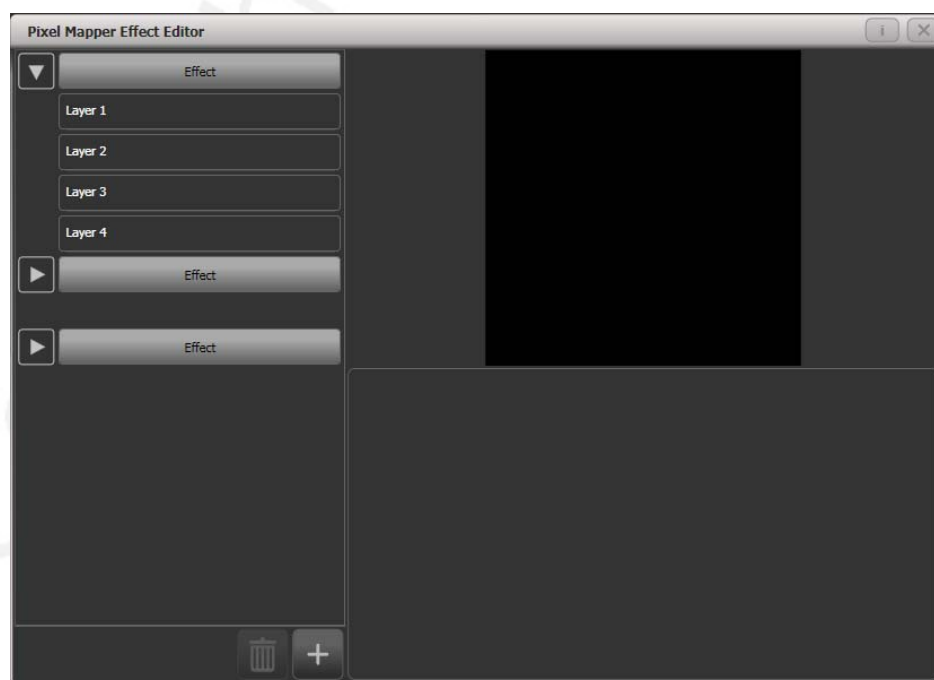

Click on the + button to add an effect, and choose a graphic element.



Then click on the + button again and choose an animation (how your graphic element will move). The animated effect will show in the black window.

Edit the parameters of the effect by clicking the effect name on the left hand side. Various sliders are provided to configure the effect.

Edit the colour of the effect by clicking on the Layer on the left hand side.

Edit the way the animation moves by clicking the animation name on the left.

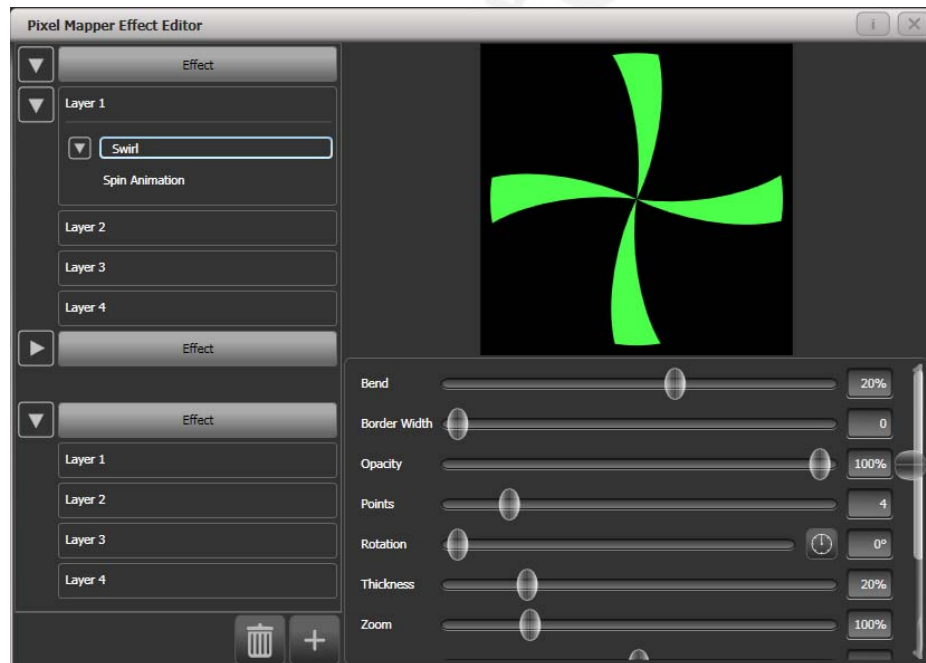

To see how the effect will look on the fixtures, open the Pixel Mapper preview window by pressing Window Open, [Open Workspace Window], [Pixel Mapper Preview]. A real life view of each effect running is shown in a button at the bottom of the screen, you can select each of these by pressing the button.

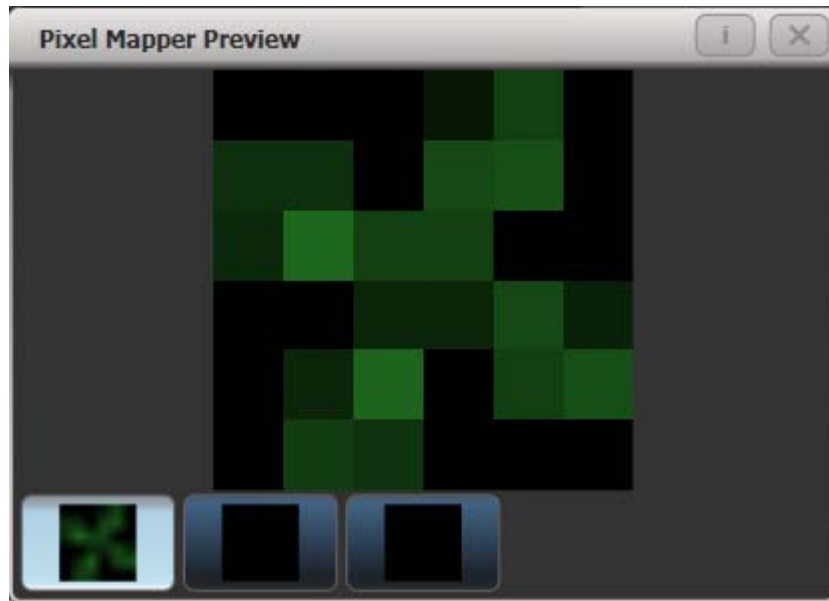

If you wish you can overlay further layers on the effect. Once you have an effect you like, you can save it to a playback.

6.2 Editing running shapes

6.2.1 Selecting which shape to edit

If more than one shape is running in the programmer, you can select which one is connected to the control wheels using Shape option [Edit].

-
- 1> *If you are not in the Shape menu, press [Shapes and Effects] then [Shape Generator] at the top menu.*
 - 2> *Press [Edit].*
 - 3> *Press [Select shape]*
 - 4> *By the softkeys is a list of the currently running shapes.*
 - 5> *Press a softkey to make the shape active. The active shape is highlighted.*
 - 6> *Press Enter to get back to the Shape Generator menu.*
-

- If you applied the same shape several times to different fixtures, you can change each copy of the shape independently.

6.2.2 Editing a shape stored in a cue

You can only edit shapes which are in the programmer, so if you fire a cue with a shape in it, the shape will not show up in the list of editable shapes. To edit the shape you need to use the Include function (see section 7.3.4 on page 111) to load the cue into the programmer.

6.2.3 Changing fixture order in a shape

The way a shape spreads across a number of fixtures is set by the order in which you selected them when you create the shape. You can change this order using the [Fixture Order] function in the [Edit] menu. The current fixture order is shown in large green numbers on

the HUD window, or in the fixture touch keys . See section 7.5.2 for details on how to set fixture order.

6.2.4 Removing or adding fixtures

You can add or remove individual fixtures from a shape using the [Add/Remove Fixtures] option in the [Edit] menu. All fixtures currently included in the shape will be selected. You can select or deselect fixtures to add or remove them from the shape.

6.2.5 Reversing a shape

You can reverse the direction of a shape by pressing [Reverse Selected Fixtures] from the shape menu. The shape will be reversed only on fixtures which are selected, allowing you to run the shape forward on some fixtures and backwards on others.

6.2.6 Deleting shapes

You can delete a running shape by pressing [Delete] from the shape menu, then pressing the softkey for the shape you want to delete.

6.3 Advanced options

6.3.1 Fading shape size and speed

When a shape is stored in a cue, you can set how the shape fades in using the Edit Times and the Playback Option settings.

To set the shape size and/or speed from the fader position, press [Playback Options] from the main menu then press the select button of the playback.

Using the [Shape Size] and [Shape Speed] buttons you can set the shape size and speed to be fixed (how you programmed them) or to grow larger/speed up as the fader is pushed up.



When you use dimmer shapes, set the playback to [Shape Size on Fader] so that the shape fades in normally when you push up the fader. Otherwise the dimmer shape will start at full brightness when the fader passes the trigger point.

To set a fixed fade in time for the shape size, press [Edit Times] from the top menu, then the playback select button, then set the Delay/Fade times you want.

The Fade Mode allows you to set mode 0 (fade in), mode 1 (fade in and out) or mode 3 (crossfade). Mode 2 links fade times to the fader position, however we recommend you use the Playback Options listed above to do this for shapes, and do not use Mode 2.

If a new cue is fired which controls the same attributes (for example, a second shape controlling the same fixtures as a currently running shape), the new shape will crossfade from the running shape.

6.4 Pixel mapper examples

6.4.1 Randomising effects

This example shows you how to use the pixel mapper to create an effect where random dimmer cells turn on. This effect will overlay any existing intensities.

- 1> The fixtures you want to use need to be recorded into a group, do this first if they are not already.
- 2> Adjust the layout of the fixtures in the group using [Shapes And Effects]/[Pixel Mapper]/[Edit Group Layout]/(select group)
- 3> Start creating an effect by selecting the group then [Shapes And Effects]/[Pixel Mapper]/[Create Effect]
- 4> In the Pixel Mapper Effect Editor window toggle the context menu option 'Fixture Overlay' until it reads 'Fixture Overlay 50/50'. (This will allow you to see the relationship of your fixtures to the effect as you create it.)

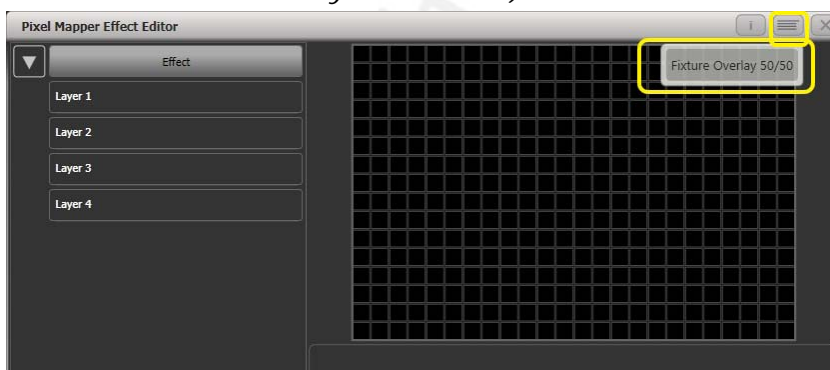

- 5> Select [Effect] and drag 'Background Opacity' slider to 0%. (This will allow the whole effect to overlay any related intensities.)

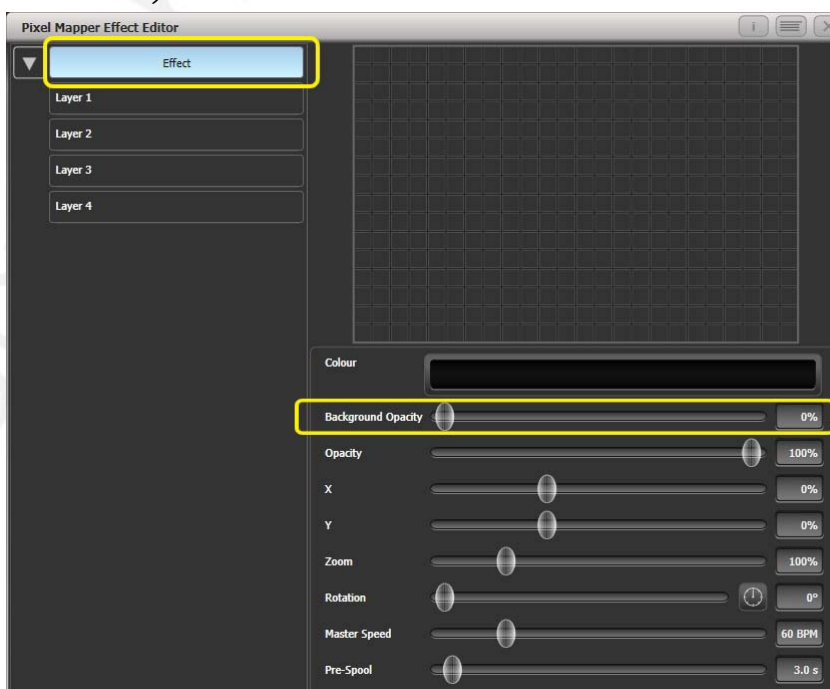

- 6> Select [Layer 1], click [+] at the bottom of the screen and then choose Circle from the elements that appear.

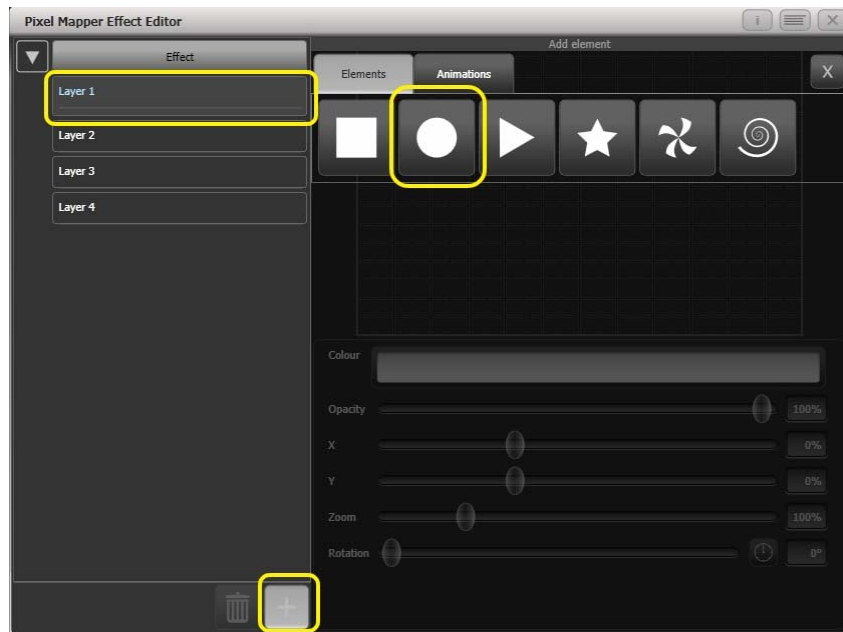

- 7> Drag the 'Zoom' slider until the circle covers approximately one cell. You can also use the 'Width' and 'Height' sliders to turn the circle into an oval if that helps.

Then drag the 'X' and 'Y' sliders to position the circle roughly in the centre of your fixtures if it is not already.

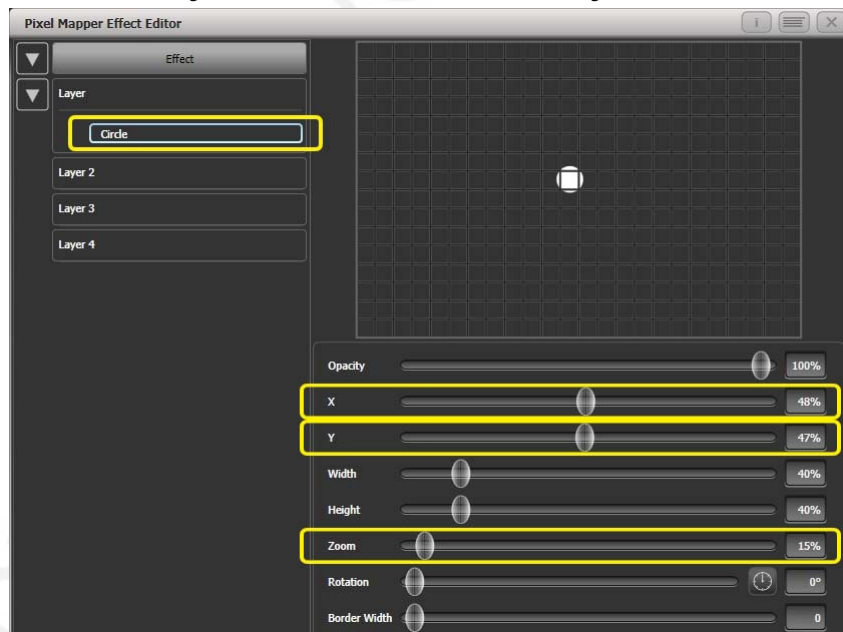

- 8> Select [+] again and choose Displacement from the animations that appear (this is represented as a few static blocks). (Note that nothing changes yet.)

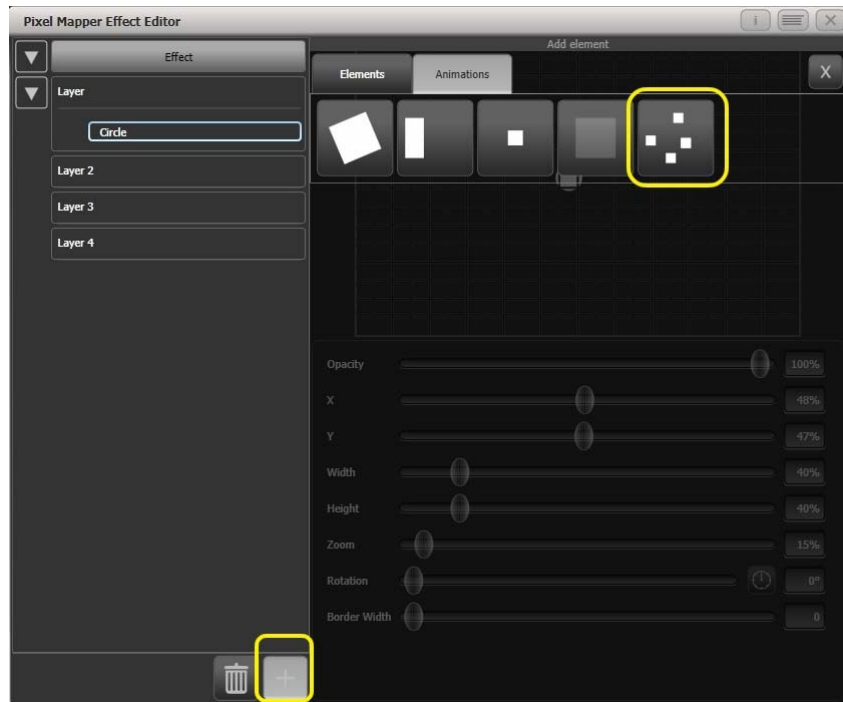

9> Select [+] and this time choose Opacity animation (represented as a block fading in).

The displacement acts on the opacity animation causing it to appear at random locations each time it is drawn.

Drag the 'In Time' and 'Out Time' sliders to 0%. (This will cause the effect to snap on/off instead of fade.)

Increase the 'Speed' and 'Spawn Rate' settings to make the effect run quicker and with more circles respectively. (High spawn rates are particularly useful for small randomised elements like this.)

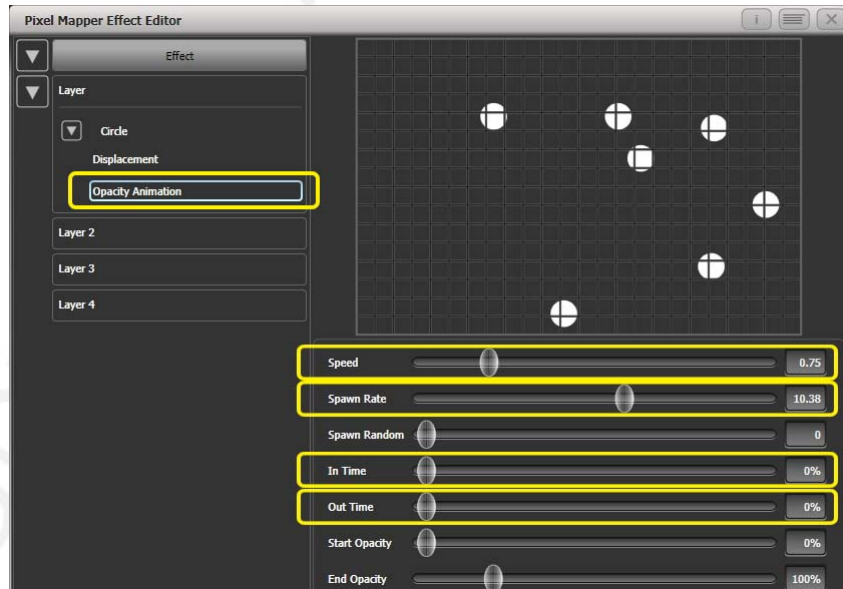

10> Record to a playback.

6.4.2 Randomising effects

This example shows you how to create a diagonal white wipe with a rotating red fan on top.

- 1> Select a group containing a fixture layout as described in previous example.
- 2> Start creating an effect by selecting the group then [Shapes And Effects]/[Pixel Mapper]/[Create Effect]
- 3> Select [Layer 1], click [+] at the bottom of the screen and then choose Block from the elements that appear.

Drag the 'Rotation' slider to the right to angle the element at approximately 25 degrees.

Drag the 'Width' slider to the left to make a thinner block.

Drag the 'Height' slider to the right until the block fills the height of the entire window.

Drag the 'X' slider to the right until the block is just off the screen.

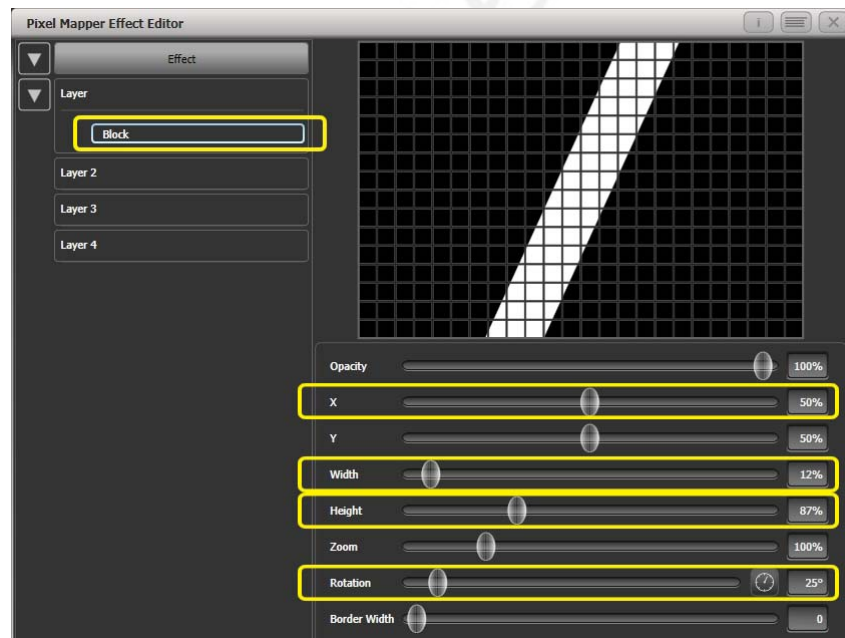

- 4> Click [+] again and choose Linear Movement animation (represented as a block moving left to right).

On the right side of the 'Direction' slider there is a compass button. Click on this four times until the direction reads 270 degrees. (By default the animation is set to 90 degrees or left to right. Because we placed the block on the far right of the screen we want it to move the other way. The compass gives shortcuts to the more common directions in 45 degree increments.)

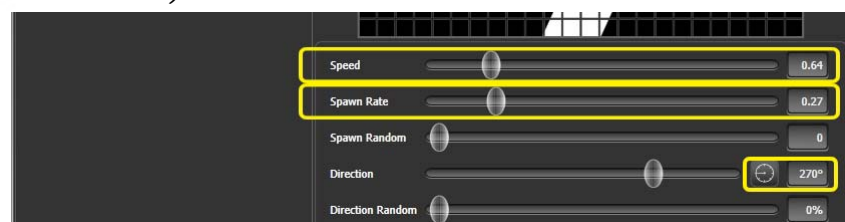

Reduce 'Spawn Rate' until only one stripe is on screen the same time. For this type of effect the value will usually need to be quite low - approximately 0.2.

You might want to reduce 'Speed' slightly at this point. (Note that a higher speed was initially useful for getting the correct spawn rate above.)

- 5> Click on [Layer 2], select [+] and select the Swirl element (represented by a 'fan' shape with four arms).

Increase 'Zoom' until it is as large as will fit in the screen.

Set 'Bend' to 0% for nice straight fan blade edges.

Set 'Points' to 3 (minimum) for a three bladed fan.

Set 'Thickness' to 50% for evenly sized segments.

Increase 'Border Width' to a low value so that we just have an outline.

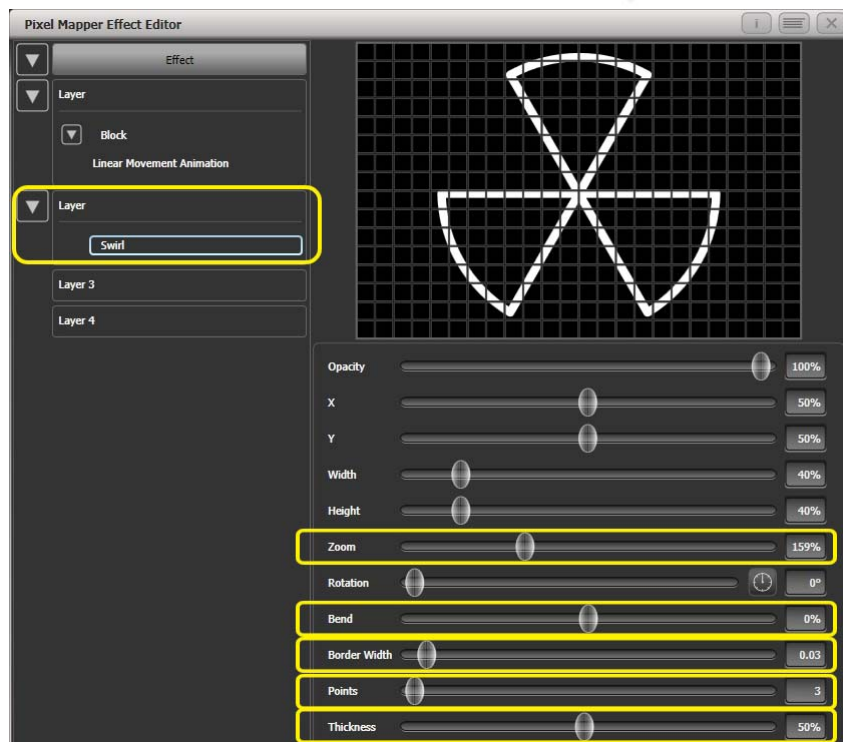

- 6> Click on [+] and add a spin animation.

Reduce the speed until it just causes a light breeze.

- 7> Click in the top of this layer to get the layer controls.

Click on the colour bar to open the colour picker.

Click and drag to the top left of the picker window to get a strong red.

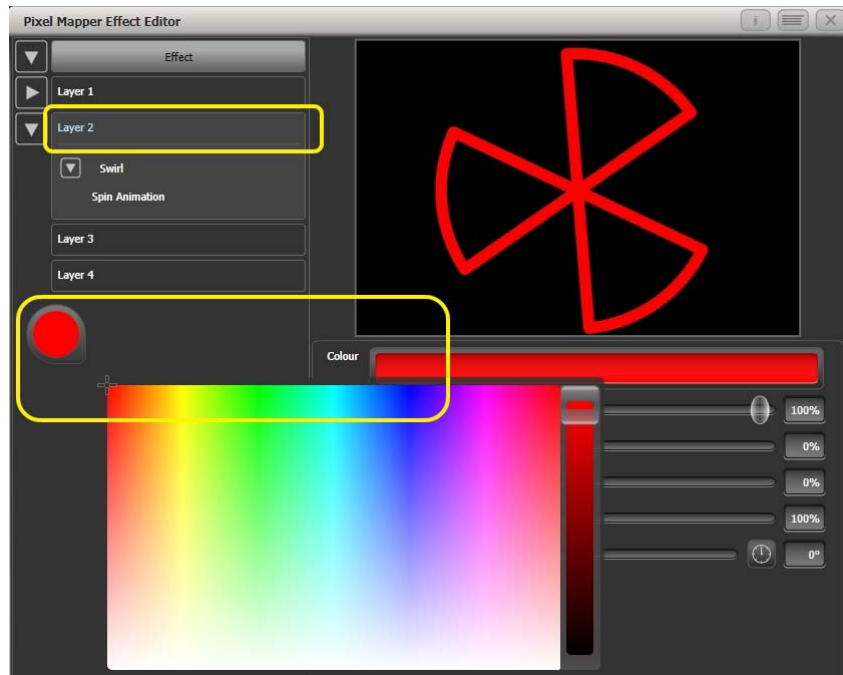

- 8> Click on [Effect] at the top left to access the global controls. Drag 'Pre Spool' to the left until it reads 0s. (This is to ensure the wipe begins off screen where we placed it when it is fired.)
- 9> Record the cue.

- Note how the red fan sits on top of the white bar when they interact. This is because the white is on a lower layer. A higher layer number has priority over a lower number.



6.4.3 Creative use of fixture layouts

Because each fixture group can contain a different layout it is possible to create more than one arrangement of the same fixtures for pixel mapping.

By arranging fixtures in certain layouts you can easily achieve complex effects.

Example 1: Odd/Even

- 1> Select your fixtures.
- 2> Open the Selection Pattern menu by pressing the 'All' key.
- 3> Choose [Odd] from the softkey options. (This will select all the odd numbered fixtures according to fixture order.)
- 4> Record a group.
- 5> Press '+1' (or 'Next') key. (This will select all the even numbered fixtures.)
- 6> Merge this into the first group.
- 7> Open the Layout Editor. ([Shapes And Effects]/[Pixel Mapper]/[Edit Group Layout]/(select group).)

By doing the above you should be able to see how we have quickly created a layout where the all the odd fixtures are arranged together on the left followed by all the even fixtures on the right.

This arrangement could be used as it is. A block element animated to run horizontally left to right will run across all your odd fixtures followed by all the even fixtures.

An alternative goal might be a vertical 'cascading' effect:

- 1> Click on the vertical resize tool and drag down until the grid is at least twice the original height.

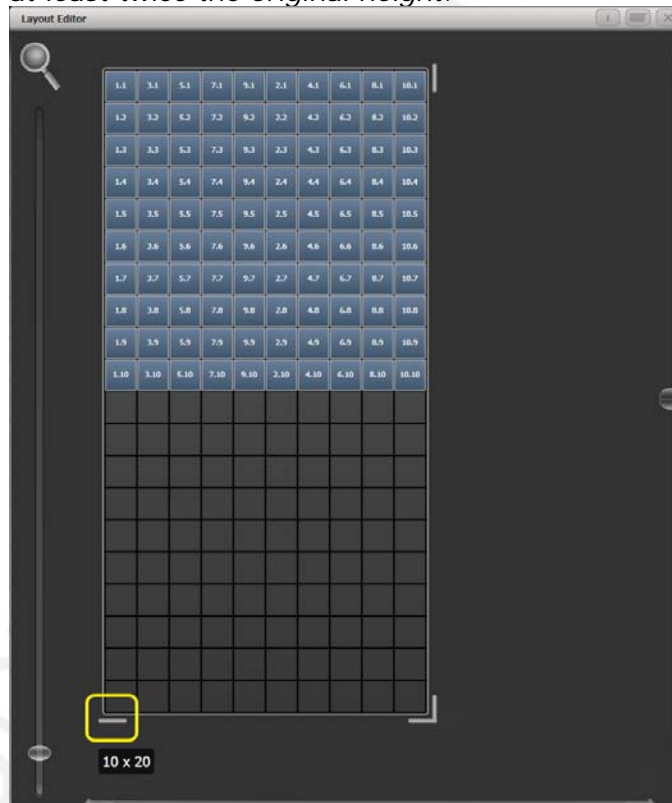

2> *Drag a marquee select across the even fixtures.*

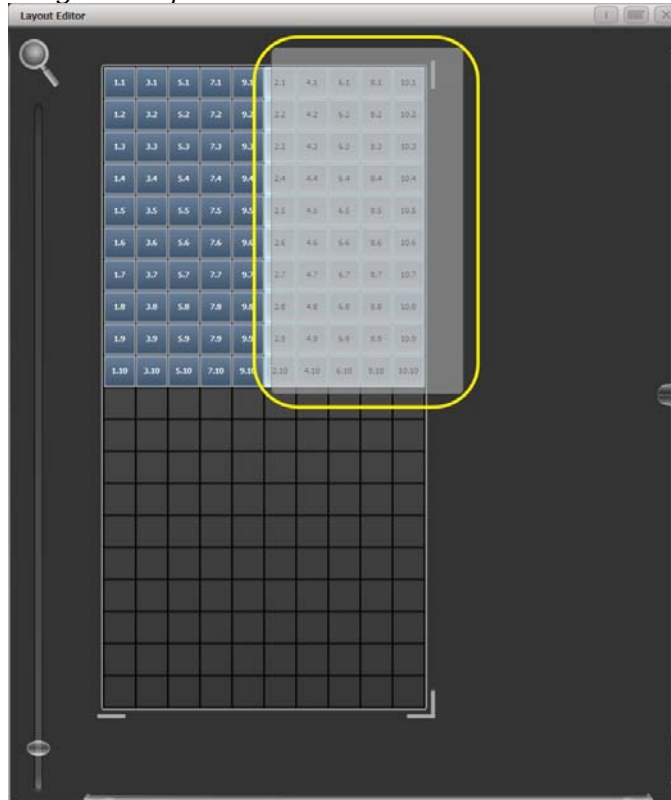

3> *Drag the selected fixtures so they sit directly under the odd fixtures.*

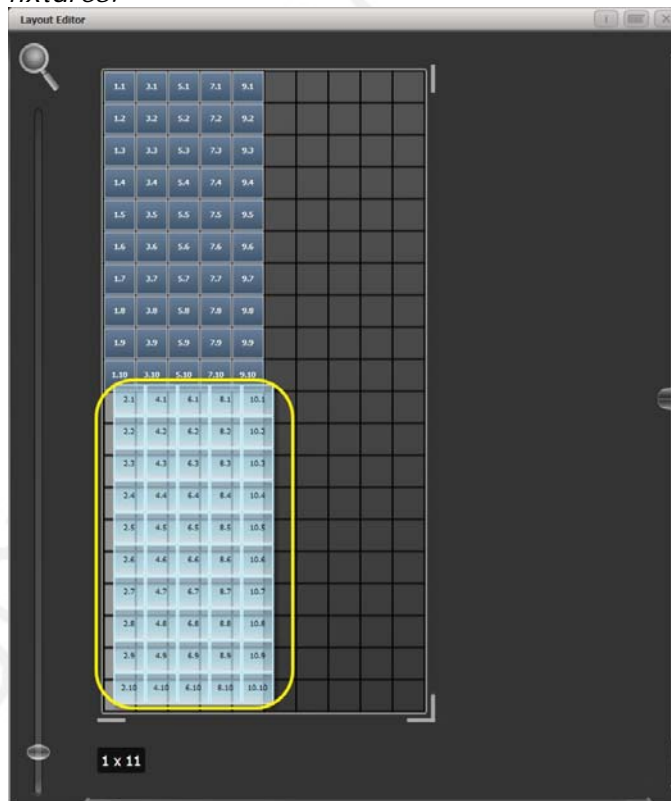

4> *Select 'Crop Grid' from the Layout Editor context menu. (This will get rid of the unused pixels.)*

Now a block element animated to run vertically from top to bottom will run down the odd fixtures followed by the even fixtures.

Example 2 - Pseudo random

- 1> Select your fixtures and create a group.
- 2> Open the Layout Editor.
- 3> Click on the vertical resize tool and drag down until the grid is at least twice the original height.
Note that to help with creation and manipulation of larger grids you can use the zoom control on the left-side of the window. Clicking on the magnifying glass gives a quick shortcut to zoom in/out.
- 4> Select the group again. (This will quickly select everything in the layout.)
- 5> Press '+1' key. (This will select the first fixture.)
- 6> Use the wheel to adjust 'Position Y'.

Repeat steps 4 and 5 until all the fixtures are at different heights in relation to one another.

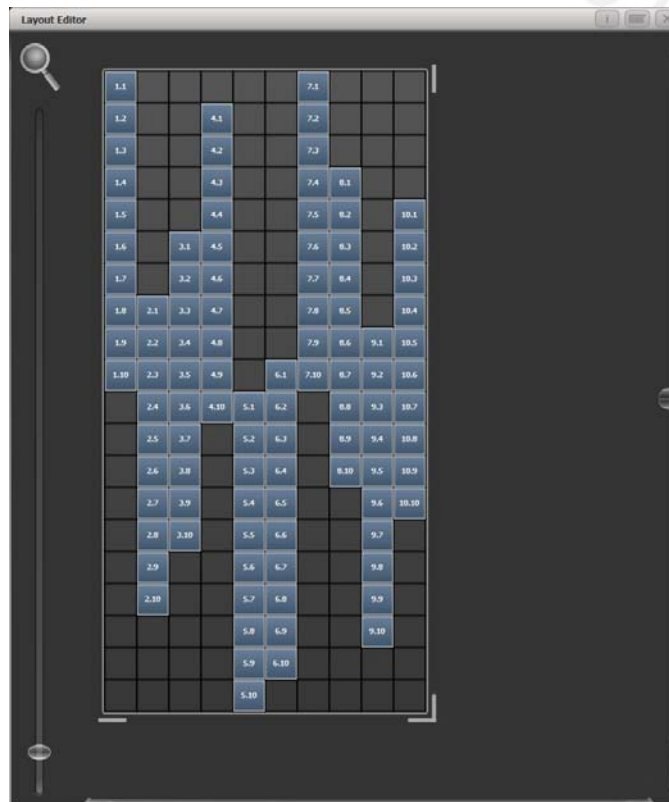

If you create an effect using this group it will appear to be random. Adjustments can be made to the layout at any time to fine-tune the end result.

Example 3 - Angles (or 'when straight just isn't good enough..'):

Sometimes we like to hang fixtures at artistic angles to look pretty. By default the software assumes you have hung them vertically but fear not - Titan has a solution:

- 1> Select your fixtures and create a group.

- 2> *Open the Layout Editor.*
- 3> *Select the fixture(s) that you want to angle and use the appropriate wheel to control. (If wheels are not assigned to control the cell layout you can toggle this on/off using the context menu item 'Wheel Control'. Also, on the Pearl Expert you may need to select 'Adjust Angle' and to return wheels to controlling position select 'Adjust X,Y'.)*

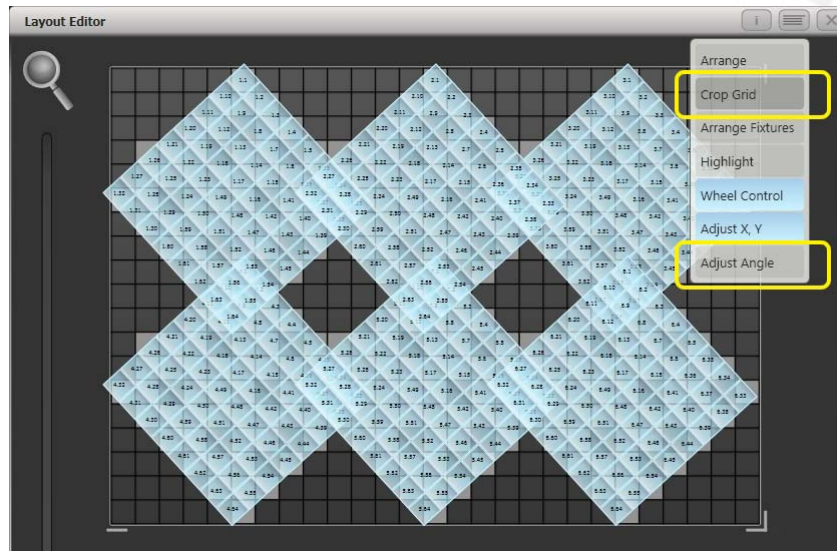

Note that underneath the visual representation of the fixtures the actual cells used are shown in light grey.

If any of your fixtures have been naughty and ended up beyond the bounds of the grid after rotating you can use context menu item 'Crop Grid' to make them behave.

6.4.4 Other Layout Editor tools

The Layout Editor's context menu has some useful tools for laying out fixtures quickly.

Context menu - 'Arrange Fixtures'

This is a very useful tool to quickly layout fixtures in a grid. For example you might have 20x Colourblocks across four towers, each with five blocks.

- 1> *Select the fixtures and create a group.*
- 2> *Edit the layout of this group.*
- 3> *Select 'Arrange Fixtures' from the context menu.*
- 4> *Select the [Height] softkey and type '5'. (Width will automatically be calculated.)*
- 5> *Toggle [Crop Grid to fixtures] so that it is highlighted. (This will make the grid adjust to fit.)*
- 6> *Toggle [Arrange in..] to 'Columns' or 'Rows'. 'Rows' will arrange fixtures left to right and 'Columns' will arrange top to bottom.*
- 7> *Select [OK] to complete.*

Context menu - 'Highlight'

When enabled this will highlight selected fixtures live on stage. This can be useful to see which fixture you are positioning in the layout.

Context menu - 'Arrange/Select Only'

When set to 'Select Only' fixtures are locked in position on the grid and cannot be dragged around. This provides an alternative way of selecting fixtures to edit while preventing accidental movement.

If you find you suddenly cannot move anything around this is probably the reason!

Note that X,Y and Angle wheel control is still available.

6.4.5 Playback Order and Priorities

Suppose you wished to create a white pulsating oval on one playback and a blue spiral on a second playback. Normally these effects would layer differently depending on the order you fire the playbacks, but you can use playback priorities to make them always layer the same way

To create first effect:

- 1> *Select a group containing a fixture layout as described in previous example and go to [Create Effect].*
- 2> *Select [Effect] to access the global effect controls and change 'Background Opacity' to zero. (This will allow it to overlay the other playback.)*
- 3> *Double-Click [Layer 1] (or press [+]) and choose Circle from the elements that appear. (Double-click is a shortcut to elements and animations.)*

Reduce height to make a rugby ball (or American football if you insist).

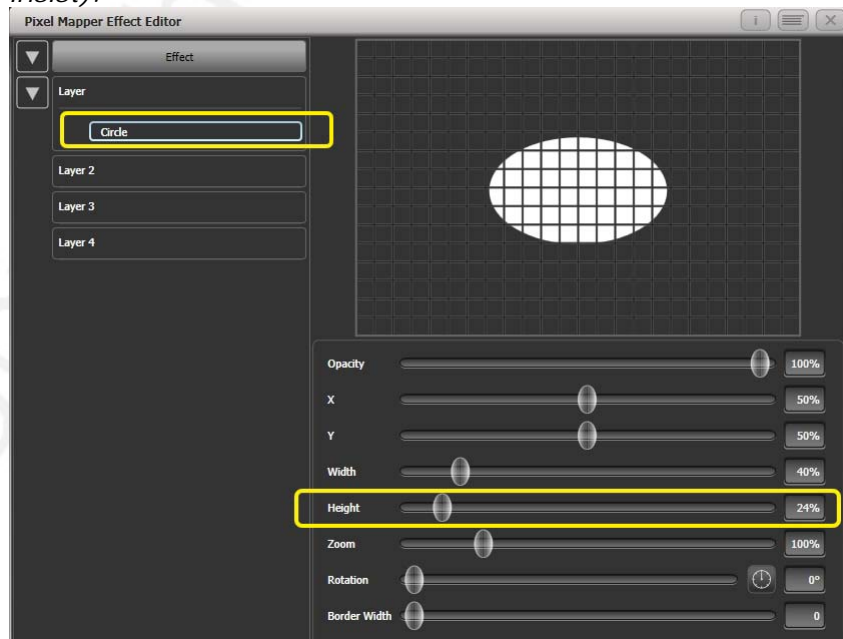

- 4> *Double-click on [Circle] (or press [+]) and select the Zoom animation.*

Drag 'In Time' to zero and 'Out Time' to 100%. (This will make the effect start large and finish small. Alternatively the same effect can be created by making 'Start Zoom' larger than 'End Zoom'.)

Increase 'End Zoom' until the element begins by filling the whole window.

- 5> Double-click on [Zoom Animation] (or press [+]) and select the Opacity animation.

Reduce 'Spawn Rate' to zero. (This will ensure the opacity only works on the zoom animation.)

Drag 'In Time' to zero and 'Out Time' to 100. (This will make the effect snap on and fade out as it reduces in size. As with zoom you can achieve much the same thing by inverting the opacity controls instead. Using opacity values greater than 100% will create a delay before fade.)

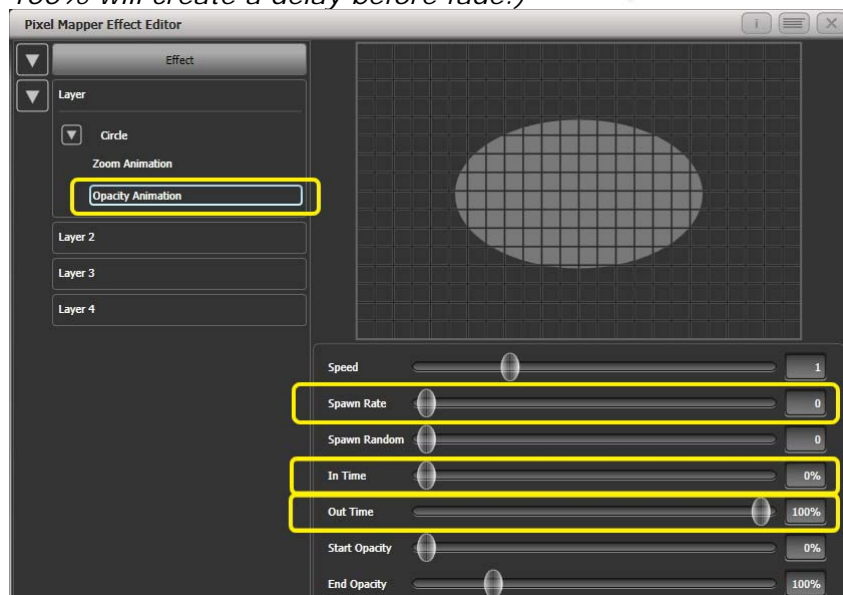

- 6> Click on [Effect] again and reduce 'Master Speed' to your preference. (Adjusting the global speed control ensures the zoom and opacity animations are synchronised instead of

having to manually match the individual values.)

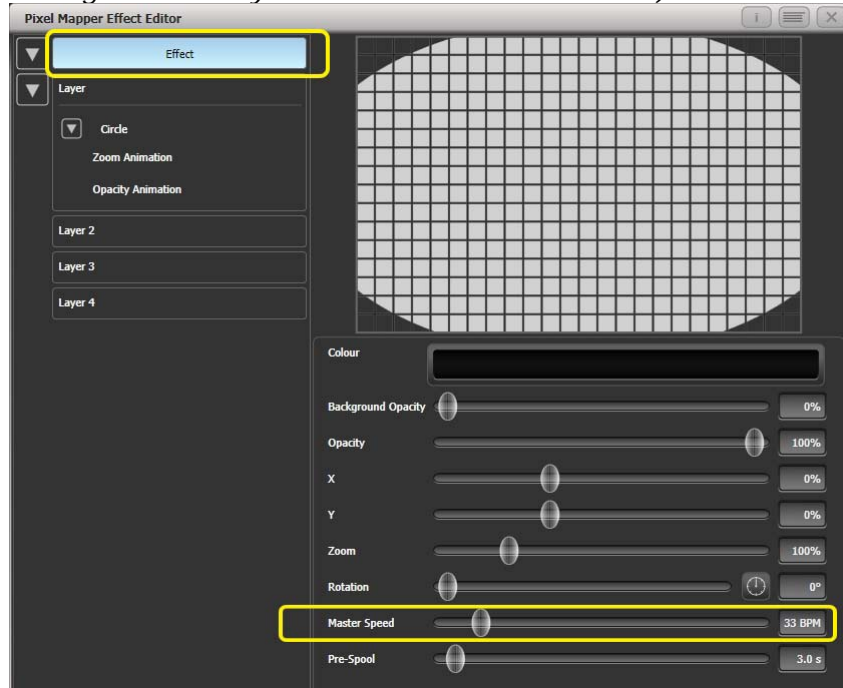

7> *Record the cue.*

Next we will create the second effect:

- 1> *Select the same group as used for the first effect and [Create Effect]*
- 2> *Select [Effect] and change 'Background Opacity' to zero as in 3.*
- 3> *Select [Layer 1] and this time add a Spiral element.
Increase 'Zoom' so that it's nice and big.
Drag 'Thinning' until it is at 0%. (This will make the lines of the spiral stay the same width. A negative value means the spiral gets thinner towards the outside; a positive value means it gets thinner towards the inside.)
Reduce 'Turns' so we can make a more bold effect. Approx. 3 should work.
Increase 'Thickness' to 50% for chunky lines.*

Increase 'Exponent' to around 25%. (This causes the spiral to 'expand' at a faster rate.)

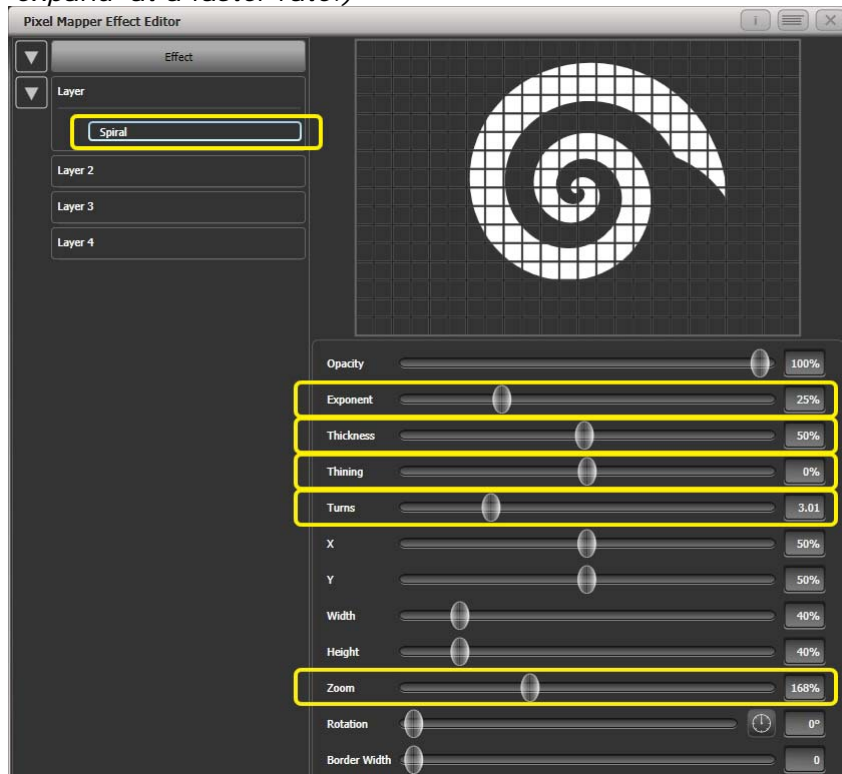

- 4> Add a Spin animation for genuine psychedelic effect. Adjust speed until you are unable to look away from the screen.
- 5> Select the Layer to show the layer controls and change the colour to blue using the colour picker.

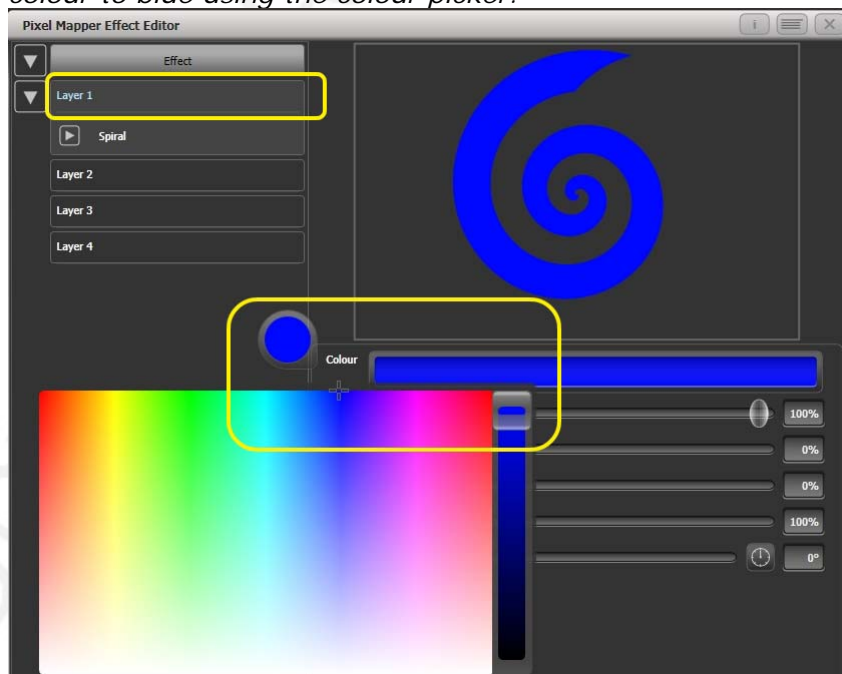

- 6> Record the cue.

Now let's look at how they interact on the playbacks:

- Fire the blue spiral effect.

- Fire the white pulse.

Notice how the white takes priority over the spiral. The blue spiral only appears as the white oval fades out and gets smaller.

- Kill both effects.
- Fire the white pulse.
- Fire the blue spiral.

This time the blue spiral sits on top of the white pulse. That is because the playbacks are following a 'latest takes precedence' rule (LTP).

To guarantee the blue spiral always sits on top you can set it to be a higher priority:

- Kill both effects.
- [Playback Options]/Select the blue spiral playback.
- Press [Previous] or [Next] until you can see [Priority Normal] on the softkeys. Press this to toggle it to [Priority High].
- Now fire the blue spiral followed by the white pulse.

Even though you fired them in the same order as the first example the blue spiral now sits on top of the white pulse because it has a higher priority.

6.4.6 Displacement and Layer Properties

In this example we create random flashing bars, and use layer controls to make global adjustments to the whole effect.

-
- 1> *Create a group and adjust the fixture layout as described in previous examples.*
 - 2> *Select this group and begin creating an effect.*
 - 3> *Select [Layer 1] and add a 'Block' element.*
 - 4> *Adjust the width and height sliders until we have a thin strip that covers at least one cell vertically and the whole grid*

horizontally.

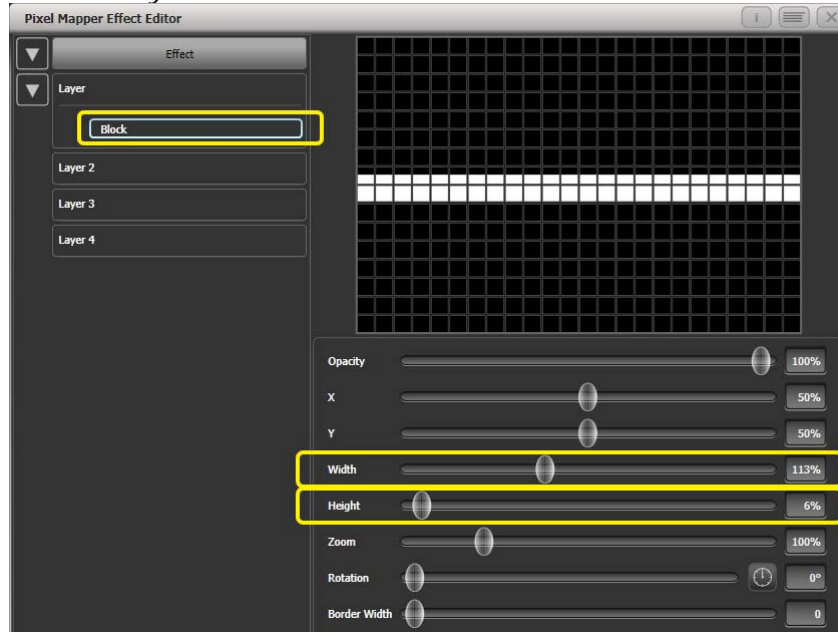

- 5> Reduce Y until the bar disappears off the top of the grid. (This is in preparation for adding a displacement animation.)
- 6> Add a Displacement animation. By default this will offset the original position by anything up to 30% distance. This is because the default value for 'Distance' is set to a maximum of 30% and 'Distance Random' is set to 100% meaning it can use any random value between zero and 30%. Similarly 'Direction Random' is set to 100% meaning it can offset in any direction. Temporarily set 'Distance Random' to zero. (This is in order to see exactly what the displacement is doing.)
- Set 'Direction Random' to zero. (In this example we do not require a random direction.) Now the bar will disappear because it is being displaced upwards in the default settings.
- Set 'Direction' to 180 degrees. Click on the compass button four times to get there quickly. Now the bar should reappear on the screen because it has been offset vertically down from the our off-screen position by the default 30%.
- Increase 'Distance' until the bar is approximately in the centre.

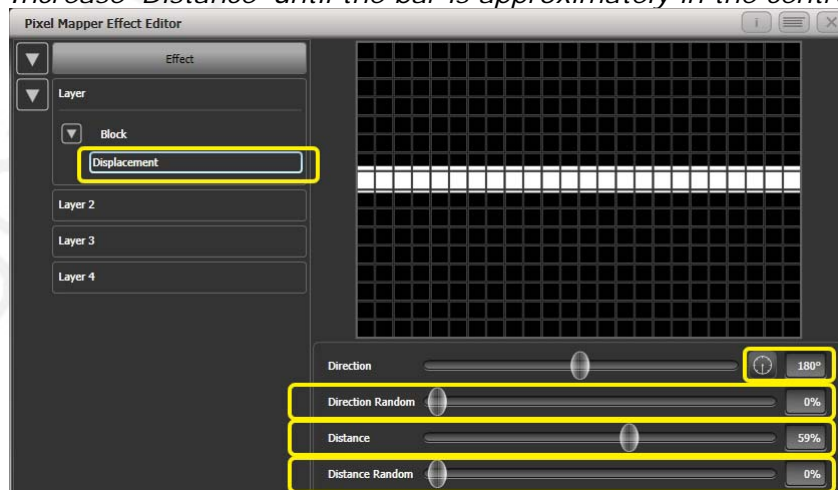

- 7> Add an Opacity animation.

Reduce 'In Time' and 'Out Time' to create a snapping effect.

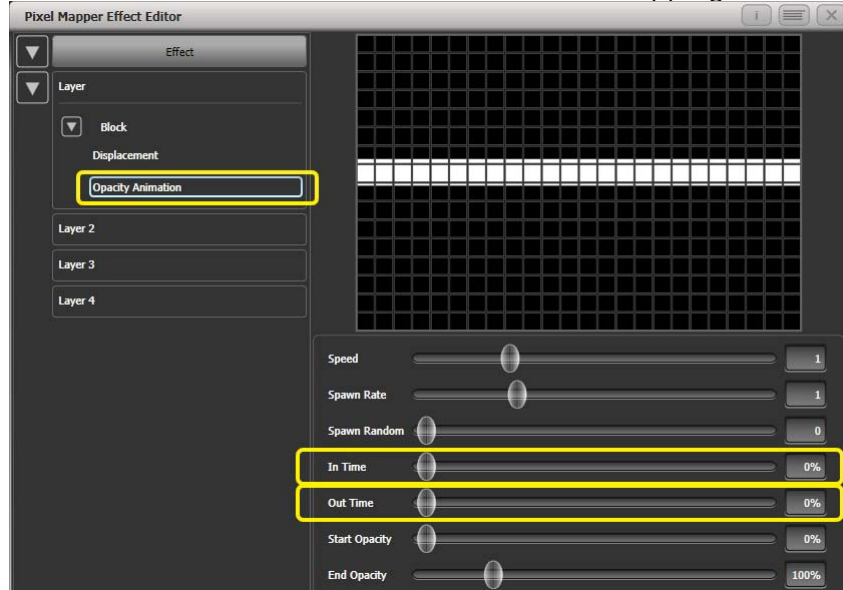

- 8> Click on 'Displacement' in the Layer to get back to the controls for this animation again.

Now increase 'Distance Random' to 100%. (This will make the bar draw at a random offset around the 'Distance' setting, in this case making it anywhere within the grid.)

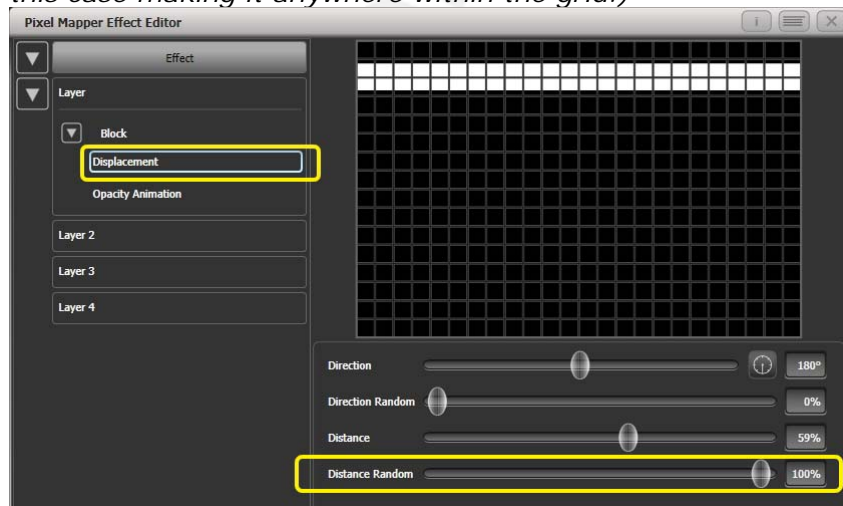

- 9> Return to the Opacity animation controls and increase speed until you're happy.
- 10> At this point you may decide actually the effect would be better if it was a vertical bar. To make this easy we can make adjustments on the layer controls rather than on the individual element and animations:

Select [Layer 1] to bring up the layer controls.

Change 'Rotation' to 90 degrees by clicking on the compass button twice.

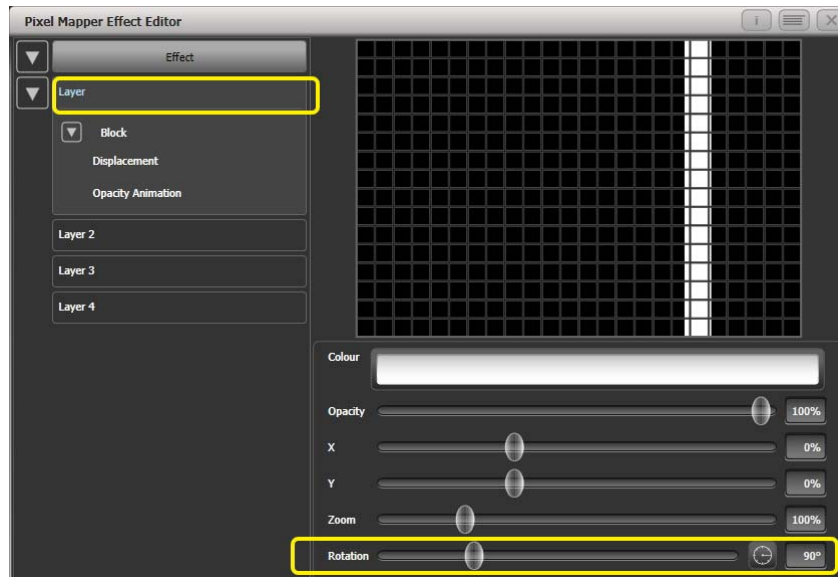

Now you have a vertical bar that draws randomly using a horizontal displacement. Similarly you can use the [layer] or [effect] controls to make global changes to X/Y position and Zoom allowing quick manipulation of entire effects.

6.4.7 Spawn and Pre-Spool

The director has asked for lots of animated spinning shurikens that slowly move across a backdrop while pulsating. It is a mystery why, but you know how it is with directors.

- 1> *Select a group with an appropriate layout.*
- 2> *Add a Star element.*
Change 'Points' to 4 for a classic shuriken.

Reduce 'Zoom' so that we can fit lots of baby shurikens in the grid.

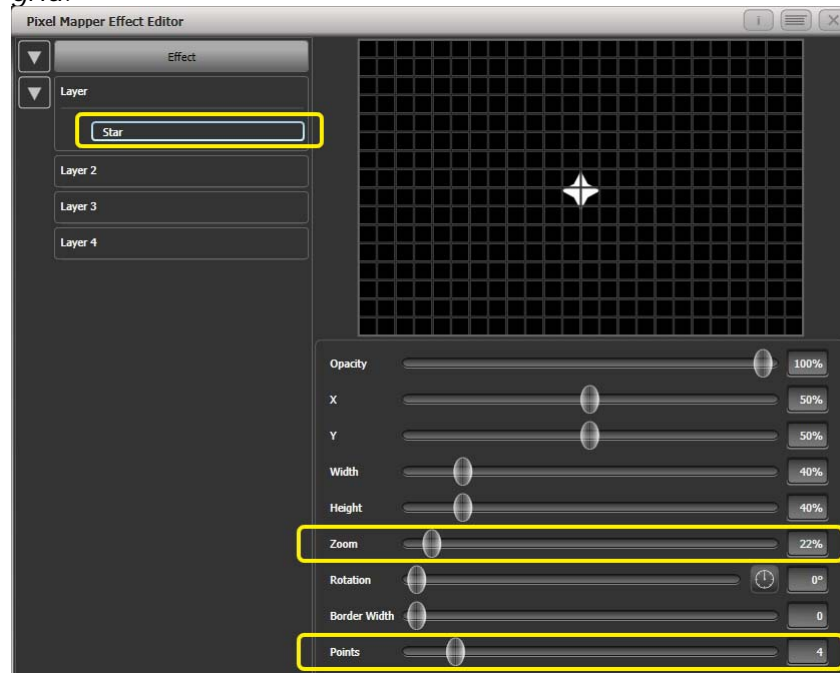

- 3> Add a Spin animation.
Reduce 'Speed' so they are relatively harmless.
- 4> Add a Linear Movement animation.
Slow it down so it looks like it is rolling along.
- 5> Select the Star element again and change 'X' so the shuriken starts further from the left and rolls along the whole grid.

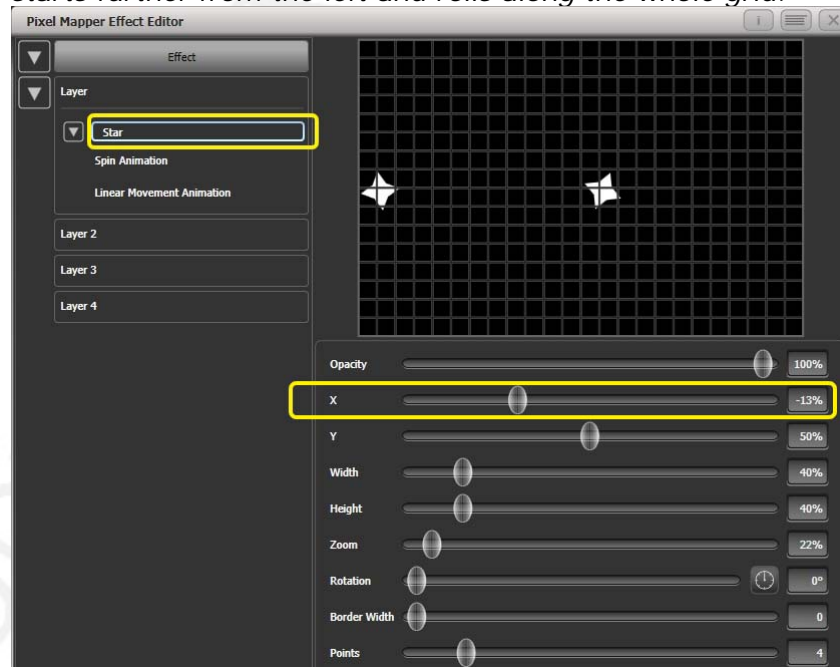

- 6> Add a Displacement animation.
Now each new shuriken starts rolling at a different height on the grid.
- 7> Go back to the Linear Movement animation and increase 'Spawn Rate' so that more shurikens are on screen at once. (This determines how frequently a new element appears.)

Increase 'Direction Random' slightly. (This will allow a random variation in the direction of travel based upon the 'Direction' value.)

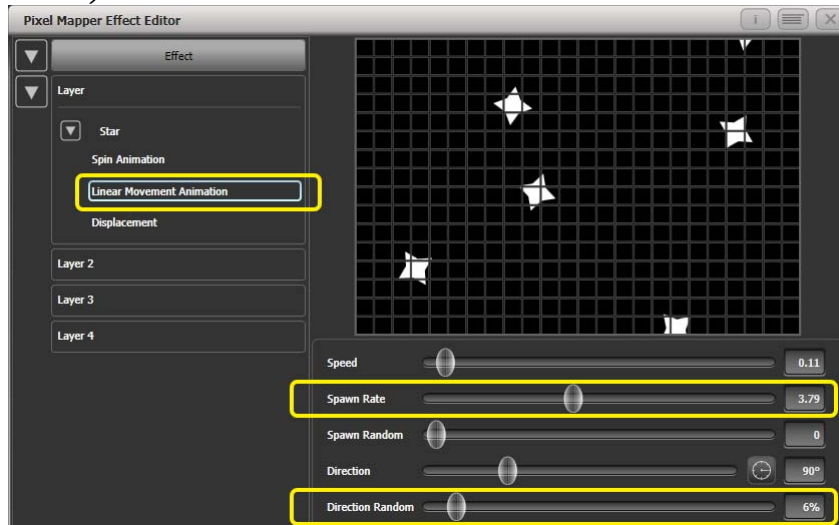

8> Add a Zoom animation.

Reduce 'Spawn Rate' to zero. (This is a special setting that will allow the zoom animation to run continuously during the life of a shuriken. If the rate is set to 1 it will only run once and the shurikens will quickly disappear as a result.)

Increase 'Out Time' to 100%. (This will make the shurikens pulse in and out with a 'bounce' type effect. I have no idea why they would be doing this in reality.)

Slow the zoom down a bit.

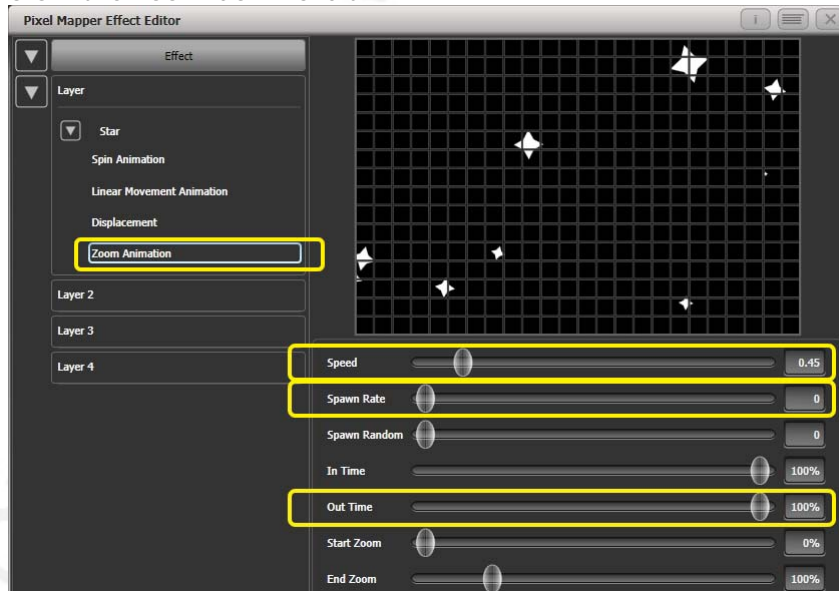

- 9> Click on [Effect] and set 'Pre-Spool' to zero. (This is to demonstrate the purpose of the property.)

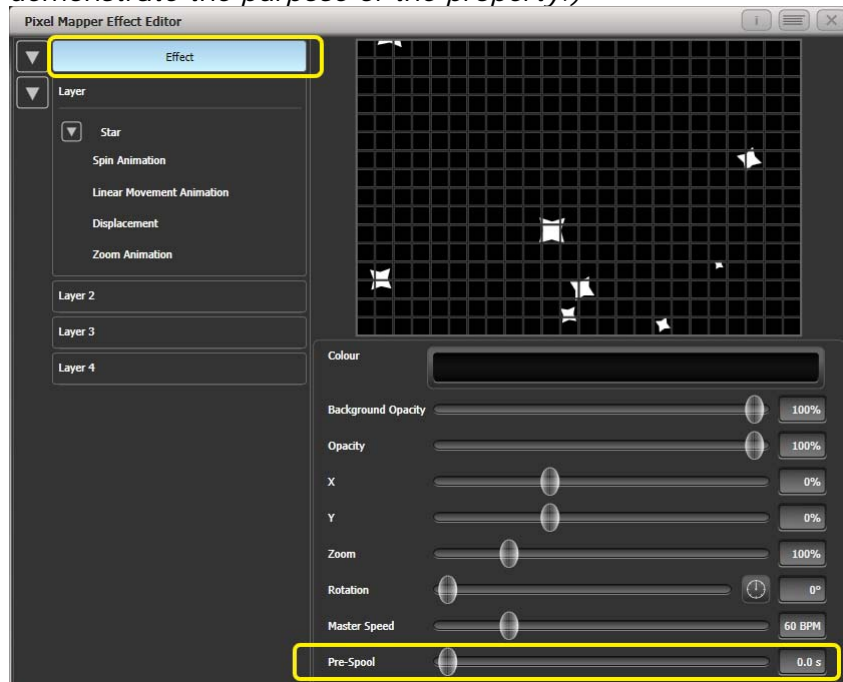

- 10> Store the cue.
- 11> Press clear, open the Pixel Mapper Preview workspace and fire the cue.
 You will notice that initially there are no shurikens on the screen and it takes a while to build up to a nice random collection. To fix that we can use 'Pre-Spool'.
- 12> Include the cue and open the Effect Editor workspace if it is not already.
- 13> Select [Effect] and increase the 'Pre-Spool' value to around 20s. (This means the software will pretend 20 seconds has already elapsed when the effect is started.)
- 14> Store the cue, clear, fire and view again in the Pixel Mapper Preview.

This time there should already be plenty of shurikens on screen. Pre-Spool is particularly useful for animations that rely on high spawn rates but run at a low speed.

Copyright Avolites 2011

7. Cues

So you've set up a great look on the stage, and you want to save it to use in your show.

There are three ways of saving looks on Titan Mobile.

Cue: This is a single look. It may contain movement in the form of shapes, and have fade in and fade out times.

Chase: This is a timed sequence of cues, often used for an individual effect.

Cue List: This is a linked sequence of cues, usually used to store and replay an entire show from a "go" button.

Cues, Chases and Cue Lists are all stored in the playback faders at the bottom left of the console. Chases and Cue Lists are covered in the following chapters.

Titan Mobile has 600 playbacks, in 60 pages of 10.

Also, you can store cues in touch buttons in the Playbacks window, provided you don't need a fader.

The cue functions on Titan Mobile are very powerful; the first part of this section explains the basics of how the console uses cues.

7.1 Creating a cue

7.1.1 How Titan Mobile works when programming

When you select one or more dimmers or fixtures for control, they are loaded into the *Editor*. You can then use the wheels and palettes to change the settings on the fixture. You can also apply shapes to it.

If a fixture is selected after you have changed some attributes then the current list of fixtures in the Editor is emptied and a new list is started.

All fixtures and attributes that have been edited since the last Clear are stored in the *Programmer*. The order in which you selected the fixtures is also stored, and is used with the Fixture Overlap function. When you record a cue, the contents of the Programmer are saved into the cue.

When you press Clear (by the numeric keypad), the programmer and editor are emptied. This makes sure you don't record fixtures you don't want. You also need to press Clear when you finish programming, because any attributes in the programmer will override playbacks.

Fixtures which are in the programmer are shown in mid blue on the HUD windows and on the touch buttons. Attributes in the programmer (the things you have changed) are shown in cyan on the HUD windows and attribute displays.

Firing a cue does not place the values from the cue in the programmer (although the Include function lets you do this, see section 7.3.4 on page 109).

7.1.2 Creating a cue

- 1> *Press Clear to clear the programmer. This ensures that you are starting with a clean slate.*
 - 2> *Set up the look using the fixtures. You can save shapes in a cue. Remember that only the fixtures you have selected will be saved in the cue.*
 - 3> *Press the Record Cue button.*
 - 4> *Press the Swop button of an empty Playback to record the cue. The handles where you can record the cue will flash. You can also record a cue onto a touch button in the Playbacks window.*
 - 5> *Press Clear to clear the programmer. Repeat from 2 to program more cues.*
-

Other useful things to know about recording cues:

- Cues can be recorded into the playback faders, the macro buttons and the onscreen Playbacks window.
- [Record Mode] lets you select Record By Fixture (all attributes of any modified fixture are saved), Record By Channel (only modified attributes are saved), Record Stage (all fixtures with a non-zero dimmer channel are saved) or Quick Build (see next section).
- Record By Channel is useful if you want to layer multiple cues to create an effect.
- If you are recording a lot of cues, you can press the Menu Latch button to keep the Record Cue menu active. Press Exit to leave Record Cue mode.
- The bottom of the screen shows a legend for the playback. To set this, press [Set Legend], then the playback Swop button (or the touch select button), then enter a legend on the keyboard. Press Enter to store it.

7.1.3 Quick Build cues

Setting [Record Mode] to Quick Build allows you to build a cue from existing playbacks or palettes (you can also use the Include function to do this).

After setting the record mode to Quick Build, the console will wait for you to select playbacks or palettes.

To insert specific fixtures from a palette or playback, select the fixtures first and then select the palette or playback.

Press [OK] once you have selected all the playbacks or palettes required.

7.1.4 Using shapes in cues

As you would expect, any shapes you have set up will be saved as part of the cue.

You can create a cue which contains a shape with no base reference values; a shape cue like this can then be fired with other cues to overlay the shape on the cue and give you instant effects based around the settings in that cue. When recording the cue, use the "Off" function to remove the other attributes from the programmer as described on page 111.

7.1.5 Blind mode

Blind mode allows you to program cues without affecting the current look on the stage. This can be very useful for making changes during a live show. Your changes are still shown in the Visualiser window.

To select Blind mode, hold down the Avolites button and select the [Blind] option. The option shows [Active] or [Inactive].

Individual playbacks can be set to Blind mode using [Playback Options]. The playback will then output only to Visualiser, not to the stage.

7.2 Using a cue

Because it's possible to play back a large number of cues at the same time, the console has to have rules on how it combines the output from different cues. These are called HTP and LTP rules.

7.2.1 HTP and LTP

Control channels are handled in two ways:

- Dimmer or intensity channels work on the principle of "Highest Takes Precedence" (HTP). If an HTP channel is active at different levels in several cues, the highest level will be output. When you fade out a cue, the HTP channels fade out with it.
- All other channels work on the principle of "Latest Takes Precedence" (LTP). The latest change takes over from any other values, so the most recent cue to be turned on is the one which is output. When you fade out a cue, LTP channels retain their values until changed by another cue.

7.2.2 Playing back a cue

To fire (play back) a cue, raise the fader. (Make sure there are no values in the programmer by pressing the Clear button, because anything in the programmer will override the playback).

- You can fire several cues at once.
- The HTP levels in the cue will be mastered by the fader level; for example if you set the fader at 50% then all HTP levels will be 50% of their programmed values.
- LTP channels are triggered as soon as the fader goes above 0%. If a fade time is programmed the LTP channels will start to fade; if there is no fade time they will snap to position (unless the cue is set to Mode 2; see the timings section 7.5 on page 113 for details of modes).
- You can Flash the cue by pressing the grey flash button. You can Swop (solo) the cue by pressing the blue Swop button (all other active cues will turn off while the button is pressed). This

assumes you haven't reassigned the function of the buttons using Key Profiles, see below.

- You can Preload the cue by assigning the Preload function to the blue or grey buttons using Key Profiles. Preload sets the attributes of fixtures in the playback which are not currently active in any other playbacks. This is useful to avoid the fixtures visibly moving into position or changing colours or gobos when you raise the fader of the cue. To assign Preload, hold Avo Shift and press [Edit Key Profile], then press the button you want to assign (also see section 12.3.4 on page 161.) Note that this will assign the function to all buttons of the same type.

7.2.3 Changing playback pages

You change playback pages using the +1 and -1 buttons to the left of the playback faders.. You can also touch the 'Pages' roller graphic and enter a page number.

If you have stored cues on the touch select buttons, you select different pages using the Playbacks page touch buttons.

- Playbacks which are fired when you change page remain active. If you want to fire a cue on a fader which is already on from a previous page, lower the fader to zero then raise it again. The cue from the previous page will stop and the cue from the new page will fire.
- If you return to a page with an active playback, the fader will not resume control of the playback until it matches the current level of the playback. This prevents the playback level "jumping" when the fader is first moved.
- You can set a legend for each playback page. The legend is shown on the 'Pages' roller on the screen and on the HUD. Use [Set Legend] from the main Program menu then [Page Legends]. While in this menu you can change the page to set legends for different pages.

7.2.4 Releasing running playbacks

You can release a running playback to its previous state by pressing the Off button, then the Select button of the playback to be released. Channels will release back to their state in the previous playback until no playbacks are left to be released, at which point they will go to the power-on state. You can release all running playbacks by pressing the blue Off button then [Release all playbacks].

Channels will always release with a fade time of 2 seconds.

- You can instantly kill a playback by pressing Avo+the swop button of the playback.
- You can set a mask to automatically release channels from the playback when the playback is killed. This uses the [Release Mask] option in the Playback Options menu (see section 7.6.1 on page 117). Normally all attributes will remain in the state last used in the playback.

7.3 Editing cues

7.3.1 Editing a cue by merging

You can edit any part of a cue you have already saved simply by making the changes and saving the new information on top of the cue.

-
- 1> *Press Clear to empty the programmer.*
 - 2> *Fire the cue you want to edit, so you can see what you are doing. Kill all other cues to avoid confusion.*
 - 3> *Select the fixtures you want to change, and make the changes.*
 - 4> *Press Record Cue.*
 - 5> *Press the Swop button for the cue you are editing.*
 - 6> *Press [Merge] (the cue being edited is highlighted on the screen)*
 - 7> *The console will merge the existing cue with your changes. Unchanged information is not affected.*
-

- If you want to overwrite the cue entirely, use the option [Replace] at step 6 – but remember that unless you are in “Record by Stage” mode, any fixtures you haven’t changed won’t be saved.
- To speed up editing, you can set the console to “Always Merge” the cue. This is option A in the User Settings (press Avo and select User Settings).
- You can also press the Swop button for the cue a second time to select the “Merge” option (quicker than selecting the softkey Merge option).

7.3.2 Updating stored values and palettes used in a cue

If you need to quickly update a cue or a palette used in a cue during a show, for example you fire a green cue and the fixtures turn out to be not quite the right colour, the Update function lets you quickly update either the cue itself or the palettes used in the cue.

For instant update of a fired cue, change the fixture settings and press Update twice.

-
- 1> *With the cue fired, select the fixtures and change them to the settings you want to store (e.g. the right green colour).*
 - 2> *Press Update.*
 - 3> *Press Enter to immediately store the new values to the cue. Alternatively, the softkeys show a list of palettes and playbacks which can be updated. Select or deselect these as required.*
 - 4> *If you have used the softkey options, press Enter to complete the update.*
-

- You can also select which palettes will be affected by pressing the palette’s button twice.
- If you manually set an attribute in the cue which was set by a palette, then press Update-Update, the palette will be removed from the cue. If you want to update the palette, use the softkey options or press the palette button.

- If you change an attribute using a different palette, the new palette will be stored instead.

7.3.3 Playback and Cue view

To see the current timings of the cue, touch the playbacks display for the fader, or press Window Open then the swop button of the playback you want to view. The screen will show details of the delay, fade, overlap and curve settings for the cue. You can touch each item to enable editing.

	Delay In	Fade In	Fade Out	Fixture Overlap	Curve	View Cue
0	0	0	Disabled	100%	Linear	View

If you touch the View button at the right hand end of the row or the [View Cue] context button, the Cue View window opens, showing you details of the settings individual timings for all the fixtures in the cue.

The Cue View has four different views: Levels, Palettes, Times, Shapes. Views are selected using the context buttons to the left of the menu buttons.

- The **Levels** view shows the individual attribute values for each fixture.
- The **Palettes** view shows which palettes have been used to record the cue. Palettes are shown by their legends. Where an absolute value was saved rather than a palette, the value is shown instead. Again you can edit or remove the values.
- The **Times** view shows individual attribute timings for fixtures. If global timings are set, no times are shown in the cue view.
- The **Shapes** view shows which attributes of each fixture are running shapes.

	Number	Order	Dimmer	Shutter	Pan	Tilt	Colour Func	Colour	Cyan	Red	Magenta	Green	Yellow	Blue	CMY Macro	Gobo 1 Func	Gobo 1
ClrSp 1200	1		100.00	Closed	49.44	55.04	Fixed	Open	0.0	0.0	99.6	-	-	-	Index 0.0	-	-
ClrSp 1200	2		100.00	Closed	43.00	57.04	Fixed	Open	0.0	0.0	99.6	-	-	-	Index 0.0	-	-
ClrSp 1200	3		100.00	Closed	57.59	57.48	Fixed	Open	0.0	0.0	99.6	-	-	-	Index 0.0	-	-
ClrSp 1200	4		100.00	Closed	47.33	54.11	Fixed	Open	0.0	0.0	99.6	-	-	-	Index 0.0	-	-
ClrSp 1200	5		100.00						0.0	0.0	-	-	-	Index 0.0	-	-	-
ClrSp 1200	6		100.00						0.0	0.0	-	-	-	Index 0.0	-	-	-
ClrSp 1200	7		100.00						0.0	0.0	-	-	-	Index 0.0	-	-	-

You can edit or remove one or more individual control values in the cue.

Touch or drag over the required control values in the grid to select them – they will be highlighted in blue.

The softkeys then give you available settings for that control value, or you can directly edit values by typing numeric values and pressing enter,

You can delete the selected control(s) using the [Delete] softkey.

Any changes take immediate effect.

7.3.4 Using parts of existing cues - the Include function

The Include function lets you load selected parts of a cue back into the programmer. (Normally, only manual changes to fixtures are put in the programmer). You can then use this to make a new cue. This is useful if you want to make a cue which is similar to one you already have, or to build a new cue from various parts of other cues. It's also useful when editing shapes in cues.

There are two modes, Quick Include and Advanced Include. Quick Include simply reloads the whole cue. Advanced Include allows you to specify which attributes of which fixtures you want to load into the programmer. So, for example, if you have a cue which contains position, colour and gobo information for 8 fixtures, you can use the include function to load only the colour information for 4 of the fixtures into the programmer. You could then Include position information from another cue into the programmer, and build up a new cue using information from several existing cues.

If you Include a chase or cue list, the screen shows you a list of the cues within it, and you select the one you want to Include using Wheel A or by touching the cue. You can also type in the cue number to Include.

-
- 1> *Press Include (above numeric keypad).*
 - 2> *Press [Quick Include] or [Advanced mode] if you want to change the mode*
 - 3> *Press the Swop button of the cue you want to include. If you are in Quick Include mode, this Includes the cue and finishes.*
 - 4> *If you are in Advanced mode, all fixtures in the cue will be selected. If you don't want them all, deselect the fixtures you don't want. The fixtures in the cue are highlighted on the HUD and on the fixture buttons.*
 - 5> *Use [Set Mask] or the Attribute Bank buttons to select which Attributes you want to include (All are included by default – Softkey C turns them all off and D turns them all on). Softkey E lets you include or exclude Shapes from the cue.*
 - 6> *Press Enter. The selected attributes of the selected fixtures will be loaded into the programmer.*
 - 7> *Repeat from 2 to include other attributes from the same fixtures, or repeat from 1 to include other fixtures.*
-

- In Quick Include mode, you can set a mask for the include by pressing one or more of the attribute bank buttons before you select the cue to include.

7.3.5 Removing attributes from cues using "Off"

The "Off" button allows you to remove an attribute which has been stored in a cue, as if you'd never recorded it.

For example, suppose you recorded a cue which had scans at a certain position, with the colour set to green. If you later decide that you don't want a colour recorded at all in the cue, so that the colour set by previous playbacks will remain, you set the colour values to Off in the programmer, which when saved will remove those values from the cue. You can also use the Off function to remove complete fixtures from a cue by selecting all the attributes.

Setting an attribute to Off is not the same as recording an attribute at zero, since this would change the attribute when the cue was fired. It is the same as excluding that attribute using the mask when recording, so the attribute will remain unchanged when the cue is fired.

-
- 1> Use the Quick Include function (described in previous section) to load the cue you want to change into the programmer.
 - 2> Press the Off button to display the Off menu.
 - 3> All fixtures in the cue will be selected. If you don't want to change them all, deselect the fixtures you don't want.
 - 4> Use the softkeys to select which Attributes you want to remove.
 - 5> Press Record Cue, then set the record mode to [Replace], and press the Swop button of the cue to update it.
-

- You can merge "Off" attributes into a cue without including it first.
- You can also remove attributes from palettes using the Off function.
- Another way to remove attributes is from the Cue View window. See section 7.3.3 on the previous page.

7.4 Copying, moving, linking and deleting

7.4.1 Copying or moving a cue

Using the Copy button you can make a copy of an existing cue, move it to a new playback, or create a new playback which is linked to the existing playback. You can copy, move or link multiple playbacks (which may be cues, chases or cue lists) in one operation.

Move is useful for tidying up the console. Linked cues are handy if you want a cue to appear on more than one page for ease of operation; also the linked cue can have different timings and playback options from the cue it's linked to.

-
- 1> Press the Copy button.
 - 2> Select [Copy], [Move] or [Link]. Pressing the Copy button again will also toggle these options.
 - 3> Press the Select button of the cue you want to copy/move/link. You can select a range of playbacks by holding the first button while pressing the last in the range.
 - 4> Press the empty Select button where you want it to go.
-

- The Menu Latch button latches the Copy/Move/Link menu, so you can keep copying, moving or linking things without having to keep pressing the Copy button. Press Exit to unlatch.

- [Retain Layout] or [Bunch Up] is used when copying a group of cues with empty playbacks in the group – you can either keep the empty playbacks, or bunch up the used playbacks together.
- When in Copy mode, option [Copy Legends] can be changed to [Don't copy legends] so that the copied cues are given default legends.
- When in Move mode, [Swap Items if Required] will attempt to reposition any existing playbacks which are in the way of the move. This is useful when rearranging playbacks on a page which is nearly full.

7.4.2 Deleting a cue

To delete a cue:

-
- 1> *Press the Delete button.*
 - 2> *Press the Select button of the cue you want to delete.*
 - 3> *Press the Select button again (or press Enter) to confirm the delete.*
-

- Press Menu Latch to keep the delete mode active. You can keep deleting using steps 2 and 3 without having to keep pressing the Delete button. Press Exit to leave latched delete mode.

7.5 Cue timing

The console allows a wide variety of timing functions to be set for each cue.

7.5.1 Setting fade times and Overlap for a cue

You can set a delay, fade in and fade out time independently for every cue. Shapes in the cue will also be affected, depending on the fade mode.

You can delay the fade times between fixtures in a cue so that the cue is applied sequentially to each fixture. This is called Fixture Overlap and can create some amazing "peel off" or "roll" type effects with no programming at all.

In the diagram below, the top picture shows how the LTP channels change when used with delay, fade and fade out times. The second picture shows how the HTP channels change. The third and fourth pictures show what happens to the LTP channels when fixture overlap and attribute fade are used.

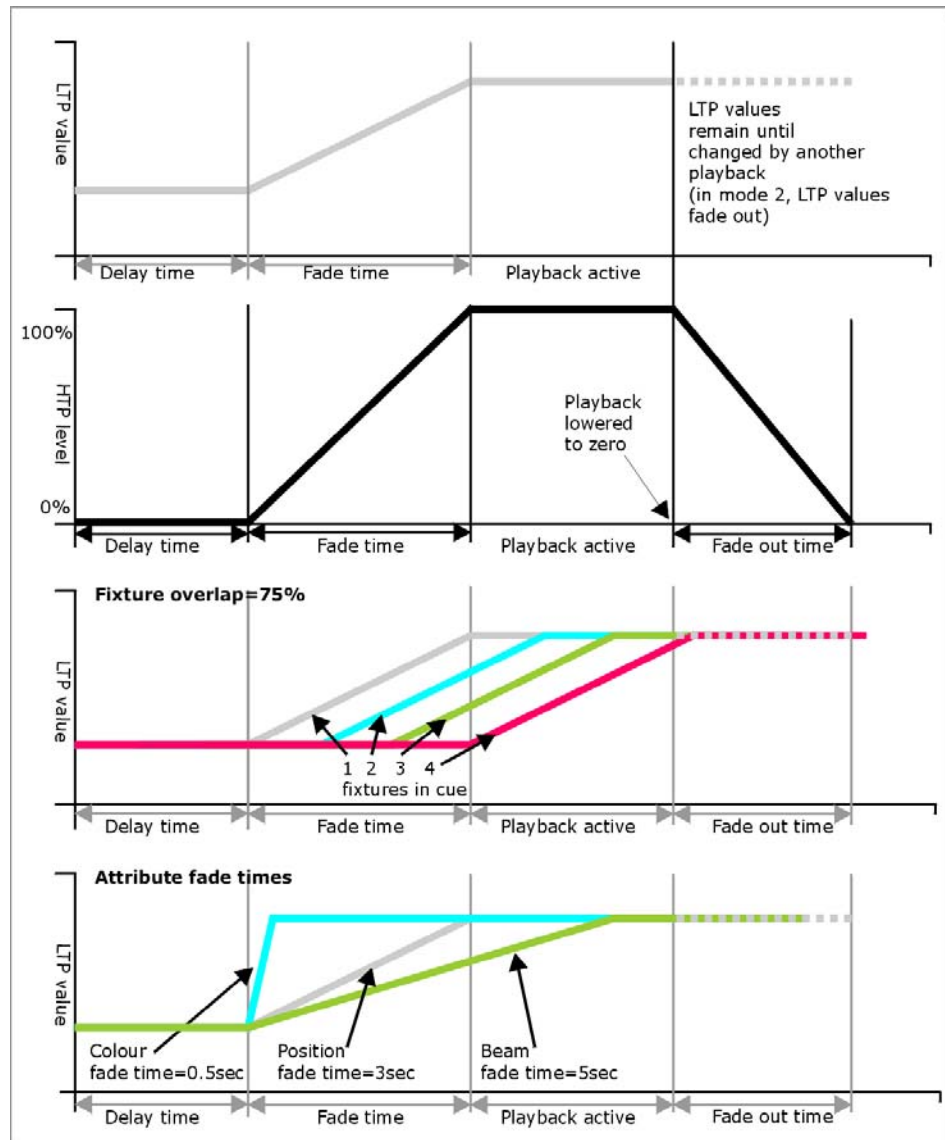

The times are set like this:

- 1> Press [Edit Times] at the top level menu.
- 2> Press the Swop button of the cue.
- 3> Press [Fade Mode x] to set the cue mode. This sets how the times are used, see below.
- 4> Press [Delay time] to set the delay before the cue starts, [Fade time] to set the fade-in time of the cue, and [Fade out time] to set the fade-out time of the cue.
- 5> Type the new time (in seconds) using the numeric keypad and press Enter to save it.
- 6> Press [Fixture Overlap] to change the overlap, then enter 0-100 on the keypad. 100% means all fixtures fade together. 0% means that the first fixture will finish its fade before the next one starts. 50% means that the 2nd fixture will start fading when the first one is half way through its fade. The order of the fixtures is set by the order you selected them (but you can change this, see section 7.5.2).
- 7> Press Exit to get out of Edit Times mode.

- You can also set independent times for the IPCGBES attribute groups, and for each individual attribute, see next section for details of this.

The times you enter are affected by the cue mode which is set using the [Fade Mode] option:

- Mode 0 – Channels will fade in as set by the fade time. The Fade Out time is ignored. If times are set to zero, the HTP channels fade in with the 0-100% position of the playback fader and the LTP channels will snap.
- Mode 1 - Channels fade in as set by the fade time. HTP channels fade out as set by the fade out times (LTP channels remain as set in the cue). If times are set to zero, the HTP levels will fade in and out with the fader and the LTP channels will snap when the cue is fired.
- Mode 2 – Channels will fade in as set by the fade time. The Fade Out time is ignored. However, the fade will stop when the fader position is reached, so if the fader is set to 50%, the attributes will stop half way to their programmed position. You can reverse the fade back to the original position by moving the fader back. If times are set to zero, both HTP and LTP channels are controlled by the fader position. In this mode LTP channels revert to their previous settings when the cue is deactivated.
- Mode 3 - Crossfade cue. All channels, including intensity channels, will fade to the settings in the new cue. All other cues fade out and all other active playbacks become inactive; if you need to re-fire a playback, take the fader to zero and put it up again.
- If the cue includes shapes, then the shape will change with fade times. The changes will be timed for a Mode 1 cue and controlled by the fader position for a Mode 2 cue. This allows you to create a shape which gets bigger or faster as you push up the fader.

7.5.2 Changing fixture order

You can change the order of the fixtures stored in a cue. Normally this is set to the order in which you selected the fixtures when the cue was created, but you might want to change this (for example to pair up fixtures so they move together when using Overlap).

-
- 1> *Press [Edit Times] at the top level menu.*
 - 2> *Press the Swop button of the cue to be changed.*
 - 3> *Press [Fixture Order].*
 - 4> *Set the sequence number to start from using option A.*
 - 5> *If you want the sequence number to increase automatically, set [Autoincrement] to On. If you want some fixtures to have the same sequence number, set it to Off.*
 - 6> *Touch the Select buttons of the fixture(s) you want to place in that position in the sequence. The sequence number is shown in*

the top right hand corner of the fixture select touch buttons.



7> *Press Exit to finish.*

- You can set several fixtures to have the same sequence number. This means, for example, when used with Overlap they will all do the same thing at the same time.
- You can remove a fixture from the sequence by turning off [Autoincrement] and pressing the fixture button twice. The fixture sequence will show X. Touch the button again to put it back in the sequence.

7.5.3 Setting attribute fade times for a cue

You can set individual fade times for each attribute group (such as Position). If you set a time, it overrides the normal times.

To set an attribute group fade time:

- 1> *Press [Edit Times] at the top level menu.*
- 2> *Press the Swap button of the cue to be changed.*
- 3> *Press the Attribute Bank button (right hand side) for the attribute you want to change.*
- 4> *Press [Delay] to set delay time or [Set fade] to set fade time.*
- 5> *Type the new time using the numeric keypad and press Enter to save it, or press [Use Global] to delete the attribute times and go back to the normal times.*
- 6> *Press Enter to save the changes.*

You can take this even further and set individual fade times for each fixture. When you select the cue to be changed, you will see that all the fixtures in the cue are selected. To set attribute times for only certain fixtures, change the fixture selection using the Swap buttons.

The Cue View window will display when editing cue timings to help you see what you are editing. You can touch fixtures or attributes in the grid to select which items are going to be edited.

Press the ALL button to select all fixtures in the cue.

When you are in the Set Attribute Times menu you can only select fixtures which are in the cue you are editing.

7.6 Advanced options

To set options for a cue, press [Playback Options] on the root menu, then press the swop button of the playback to be edited.

These options are also available for Chases and Cue Lists.

7.6.1 Release mask

[Release Mask] lets you specify which attributes will be released to the state they were in from a previously fired playback when this playback is killed (you lower the fader to zero). You can also use the Attribute Bank buttons to set the mask. The default setting is to not release any attributes.



Release mask is useful when creating a temporary strobe effect on a playback. Press [Release Mask] then the Shutter attribute button (Intensity on Titan Mobile). Now when you turn off the playback the shutter will release to its previous state and the strobe will stop.

When using with chases you need to press [Mask] before pressing the Shutter button.

7.6.2 Shape size/speed on fader

If the cue contains shapes, options B and C set how the shape behaves when the playback fades in. You can set the size and/or speed to be either fixed or to change with the fader.

7.6.3 Curve

[Curve] defines how the attribute values will change when the playback is faded in. The various curves are illustrated in section 12.5 on page 163.

7.6.4 Handle Paging

This option allows you to lock the playback on a handle so that it always appears on that handle no matter what page is selected. This is useful if you have some general playbacks you want on every page, without having to copy the playback onto each page.

If you select "Transparent Lock" then the playback will appear on the current page only if no other playback is programmed in that position.

7.6.5 Playback priority

This option allows you to configure how playbacks will behave if you turn on two playbacks controlling the same fixture. The priority can be set to Low, Normal, High or Very High. If a fixture is being controlled by a playback and you turn on a playback of the same or higher priority, then the new playback will take over. However, if the new playback is set to lower priority than the first playback, the fixture will not change.

This is useful if, for example, you've programmed looks using all your fixtures, then you decide you want a couple of them to spotlight a singer. If you set the Spotlight playback to be high priority, then while it is active no other playback will affect the spotlight fixtures.



Priority is useful when using Swop buttons for strobe-type effects where you want to black out everything else. If you have a position shape running on other fixtures, you don't want that to stop during the Swop, or it will look messy when you release the Swop button. So set the shape playback to have a higher priority than the strobe playback, and it will keep going during the strobe and continue smoothly when you release the Swop button.

7.6.6 Blind mode

Individual playbacks can be set to Blind mode using this option. The playback will then output only to Visualiser, not to the stage. This can be very useful if you need to program cues during a live show.

7.6.7 Key Profile

Each playback can have an individual Key Profile allocated to it. This allows you to customise the panel button functions differently for each playback. A list of available Key Profiles is shown, or you can add a new one. The softkeys show the function allocated to the blue and grey buttons for each of the available Key Profiles.

If the playback Key Profile is set to "None", the default global profile is used.

8. Chases

As well as being used to store static cues, the playback faders can also be used to store chases (sequences of cues). You can also store chases on touch buttons in the Playbacks window.

Chases can run once or repeat continuously. You can set individual fade time for each cue in the chase and unlink cues so that the console waits for you to press Go before the chase continues.

8.1 Creating a chase

8.1.1 Programming a chase

To program a chase, you have to set up the look for each cue in the chase, then save it.

You can either set all the fixtures and dimmers manually for each cue in the chase, or you can use Include to load in the information from cues you have already recorded.

-
- 1> *Press the Record button, then select [Chase] .*
 - 2> *Press the Swop button of the playback where you want to store the chase (you can also store chases on touch buttons in the Playbacks window).*
 - 3> *Set up the look for the first cue, either manually or by using "Include" on existing cues.*
 - 4> *You can change the number given to the step using [Step Number].*
 - 5> *Press the Swop button of the playback to store the programmer contents as a step of the chase. You can also press [Append Step] on the menu.*
 - 6> *Press Clear (unless you want to re-use the contents of the programmer), then repeat from step 3.*
 - 7> *Press Exit to finish when you have stored all the cues you want.*
-

- [Record Mode] lets you select Record By Fixture (all attributes of any modified fixture are saved), Record By Channel (only modified attributes are saved), Record Stage (all fixtures with a non-zero dimmer setting are saved), or Quick Build (see next section).
- The cue number currently being saved, and the total number of cues, is shown on the top line of the display.
- Press Clear when you have finished recording the chase, otherwise when you try to play it back the programmer will override the chase and you won't see the chase properly.
- You can record shapes in a chase. If the same shape is saved in subsequent cues it will continue from step to step and if not it will stop at the end of the cue. (The shape is the same if you didn't press Clear after the previous step, and didn't change the speed, size or phase of the shape from the previous step; or if you Included the shape from the previous step and have not modified it)

- You can set a legend for the chase by pressing Set Legend, then pressing the Swop button for the chase and entering the legend, as with cues.
- There is no limit to the number of steps in a chase.

8.1.2 Creating a chase with Quick Build

Quick Build mode, as the name suggests, allows you to build a chase very quickly from existing palettes and playbacks.

Start recording a chase as described in the previous section, set [Record Mode] to Quick Build.

Select any palette or playback to insert that item as a step in the chase. If you select multiple palettes by selecting a range of buttons, each palette will be added as a separate step.

To insert specific fixtures from a palette or playback, select the fixtures first and then select the palette or playback.

8.2 Playback

8.2.1 Playing back a chase

To fire a chase, raise the fader of the playback. (You can also use the Flash/Swop buttons). The chase will start to run. The bottom line of the screen relating to the playback fader shows the current cue number and speed of the chase.

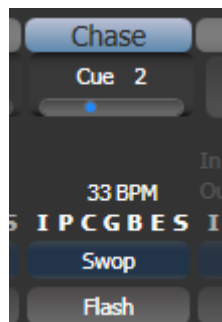

- The HTP (intensity) channels in the chase will be controlled by the fader; if fade times are programmed, the fade will stop at the fader level. The other channels (LTP) will be set as soon as the fader moves above zero according to the fade times programmed in the chase. You can set the point at which the LTP channels activate from the User settings menu.
- While the chase is running, the area of the screen above the wheels shows details of the chase steps.

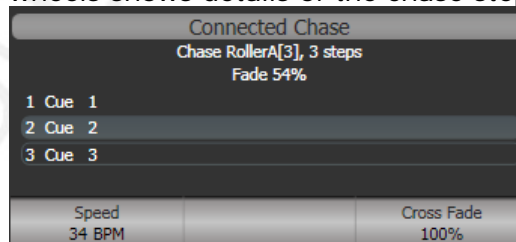

- You can temporarily pause the chase by pressing the Stop button near the wheels. Press Go to resume playback.

There are many options you can set to determine the way the chase runs and these are described in the rest of this chapter.

8.2.2 Connecting a chase for control

When you fire a chase, the wheels and Stop/Go buttons are automatically allocated to control the Speed and Crossfade of the chase – this is called Connecting the chase. If you have more than one chase running, you can choose which chase is connected to the controls using the Connect button.

- Connect a different chase to the controls by pressing the Connect button then the Swop button of the chase you want to control.
- Disconnect a chase from the controls by double pressing the Connect button.
- You can turn off the “chase autoconnect” option in the User Settings menu if you don’t want to connect to a chase when you fire it. You will have to use the Connect button to control the chase if you do this.
- Normally if you change the speed or crossfade of a chase, the new setting is saved. However you can set this change to be temporary, so that when the show is reloaded the speed and fade will go back to the previously saved settings. Go to User Settings (Avo button + [User Settings]) and set option C to [Connected View Sets Temporary Chase Speed]. You can still save a temporary speed by pressing [Save Temporary Speed] in the Set Times menu.

8.2.3 Setting speed and crossfade for a Chase

The left wheel is assigned to control the Speed of the chase it is connected to. The speed is shown in Beats Per Minute (BPM) on the display. You can also enter a speed from the keypad as described below. The last speed you set on the wheel is always remembered, you do not have to tell Titan Mobile to save it.

Crossfade is the “slope” between cues; with a crossfade of 0, the fixtures snap instantly to the next cue, but with a crossfade of 100, the fixtures spend the whole cue time fading to the next cue. With a crossfade of 50, the fixtures delay for half the cue time and fade for the other half of the time.

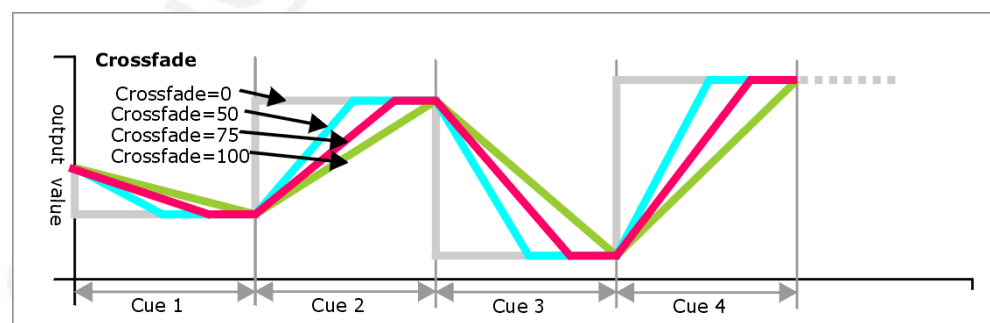

You set the crossfade and speed as follows:

- 1 > Press [Edit Times] from the top level menu then the Swop button of the chase.

- 2> *To set the crossfade, press [Xfade] and type the fade from 0 – 100. 0=no fade (the chase will “snap”), 100=max fade (the chase will move continuously from step to step).*
 - 3> *To set the speed, press [Speed], type the new speed, then press Enter. The speed can be set in Beats Per Minute (BPM) or seconds depending on the User Settings.*
-

There are other options you can set for the chase from this menu including Fixture Overlap, which are described in the Timings section 8.5.1 on page 124.

You can set individual times for each cue in a chase and unlink cues from each other so they wait for you to press the Go button. This is done using the Playback View, or the Unfold function which is described in section 8.3.2 on page 123.

You can select whether the chase speed is displayed in Seconds or in Beats Per Minute (BPM). Press Avo and [User Settings], then press [Tempo Units] to set the option to [Tempo Units Seconds] or [Tempo Units Beats Per Minute (BPM)].

8.2.4 Manually controlling the steps of a chase

You can pause a chase, if the chase is connected to the wheels, by pressing the Stop button next to the wheels. Press the red Go button to resume playback of the chase.

While the chase is stopped you can use the Prev Step/Next Step buttons next to the Connect button to move to the next or previous step.

You can also configure the blue and grey buttons of the playback handle to be Stop and Go. This uses the Key Profiles function.

-
- 1> *Hold Avo and press [Edit Current Key Profile].*
 - 2> *If you are using the default Key Profile which is not editable, you will be prompted to add a new profile.*
 - 3> *Press [Chases] then choose either the Blue key or the Grey key.*
 - 4> *Select Go or Stop from the list of functions. Then press Exit and set the function for the other key if required.*
 - 5> *Press Exit to continue using the console.*
-

8.2.5 Changing chase direction

The Prev Step/Next Step buttons next to the Connect button set the direction of the connected chase. bounce

8.2.6 Jumping to a step

You can jump directly to a step in a chase by pressing the Connect button, then typing in the desired step number, then pressing Enter or softkey A. Alternatively at the top level menu you can type the step number then press Connect.

8.3 Editing a chase

8.3.1 Opening a chase for editing

You can open a chase for editing by pressing Chase then the Swop button of the chase. This does not affect any existing cues in the chase. You can then save new cues at the end by pressing the Swop button just like normal recording.

To see a list of the cues in the chase, use Playback view (touch the playback display above the fader or press Window Open then the Swop button of the playback). To edit any of the time settings in each cue, select the setting to be modified by touching or dragging in the grid, then use the softkey options to change the setting.

Playback View - Chase 'PRESS GO'							
	Legend	Delay In	Fade In	Fade Out	Fixture Overlap	Link	View Cue
1	Cue 1	Global	Global	= As In	Global	After Previous	View
2	Cue 2	Global	Global	= As In	Global	After Previous	View
3	Cue 3	Global	Global	= As In	Global	After Previous	View
5	Cue 5	Global	Global	= As In	Global	After Previous	View
6	Cue 6	Global	Global	= As In	Global	After Previous	View
7	Cue 7	Global	Global	= As In	Global	After Previous	View
8	Cue 8	Global	Global	= As In	Global	After Previous	View

8.3.2 Editing a chase using Unfold

Unfold provides another way to edit chases. The Unfold button places each cue in a chase on one of the playback faders, allowing you to fire and edit each cue individually as if it was a stand-alone cue. Unfold also allows you to set individual timing for cues in the chase.

-
- 1> Press the Unfold button, then the Swop button of the chase to be edited.
 - 2> The first 10 cues of the chase are loaded into the playback faders.
 - 3> Raise a playback fader to output the contents of that cue (fade times will operate as programmed).
 - 4> Various Unfold options are available, the details are below.
 - 5> Press Unfold again to get out of unfold mode.
-

- To edit the contents of a cue: Press Clear to empty the programmer, raise the fader to output the cue, make the changes, press [Record Step], then the Swop button for the cue number.
- To Insert a new cue at the end of the chase, set up the look for the new cue, press [Insert Step], then press the swop button of the first free playback.

- To Insert a cue between two other cues, set up the look for the new cue, press [Insert Step], then type the cue number for the new cue (such as 1.5 to go between 1 and 2). If this cue number already exists it will be merged with the look you have created. Otherwise a new cue is inserted.
- To change individual times for the cue, press [Edit Times], then the Swop button for the cue (or type the cue number), then set the times. This is described in detail in the Timing section on the following page.
- If the chase has more steps than there are playback faders, you can go between pages using the [Previous Page] and [Next Page] buttons.

8.4 Copying, moving, linking and deleting

8.4.1 Copying or moving a chase

Chases can be copied or moved to a new playback, or you can create a linked copy of a playback. Move is useful for tidying up the console. Linked chases are handy if you want a chase to appear on more than one page for ease of operation; the linked chase can have different timings and playback options.

This operation is exactly the same as for Cues and is described in detail in section 7.4.1 on page 112.

8.4.2 Deleting a chase

You can delete an entire chase by pressing the Delete button followed by the Select button of the chase to delete. Press once more to confirm.

8.4.3 Deleting a step from a chase

To delete a single step from a chase:

-
- 1> *Press the Delete button.*
 - 2> *Press the Swop button of the chase.*
 - 3> *The steps in the chase are listed on the screen. Use the left hand wheel to select the step you want to delete, or type in the number of the step to be deleted.*
 - 4> *Press [Delete Cue x] to delete the step.*
 - 5> *Press [Confirm] to confirm the delete.*
-

- Alternatively you can use the Unfold function to delete a step from a chase.

8.5 Chase timing

8.5.1 Global timings for chases

When a chase is first programmed, each cue in the chase has identical timing. This is called the global timing for the chase. If you want you can then set each cue to have its own timings using the Playback View window or Unfold. This is described in the next section.

-
- 1> *Press [Edit Times] from the top level menu then the Swop button of the chase.*
-

- 2> Set the Crossfade, Speed, Fixture Overlap and Attribute Overlap settings as described below.
- 3> Press Exit to finish.

- To set speed, press [Speed] then type the new speed, then press Enter. The speed can be set in Beats Per Minute (BPM) or seconds depending on the user settings.
- To set crossfade, press [Xfade] then type the fade from 0 – 100 and press Enter. 0=no fade (the chase will “snap”), 100=max fade (the chase will move continuously from cue to cue)
- When in Run mode, you can set the chase speed of the connected chase by tapping the [Tap Tempo] button in the main menu at the speed you want the chase to run. (The option only appears when a chase is connected). You can also assign the blue or grey handle button to be a “tap tempo” button using the Key Profiles option (see section 12.2.1 on page 157).

The Overlap functions allow you to offset and overlap the timing of changes in the chase. This can create really amazing visual effects with hardly any programming. The best way to learn about overlap is to program a chase with two cues involving several fixtures, then experiment with the overlap settings to see the various “roll” and “peel off” effects which result.

The following diagram shows you the effects of cue overlap, fixture overlap and attribute overlap in chases.

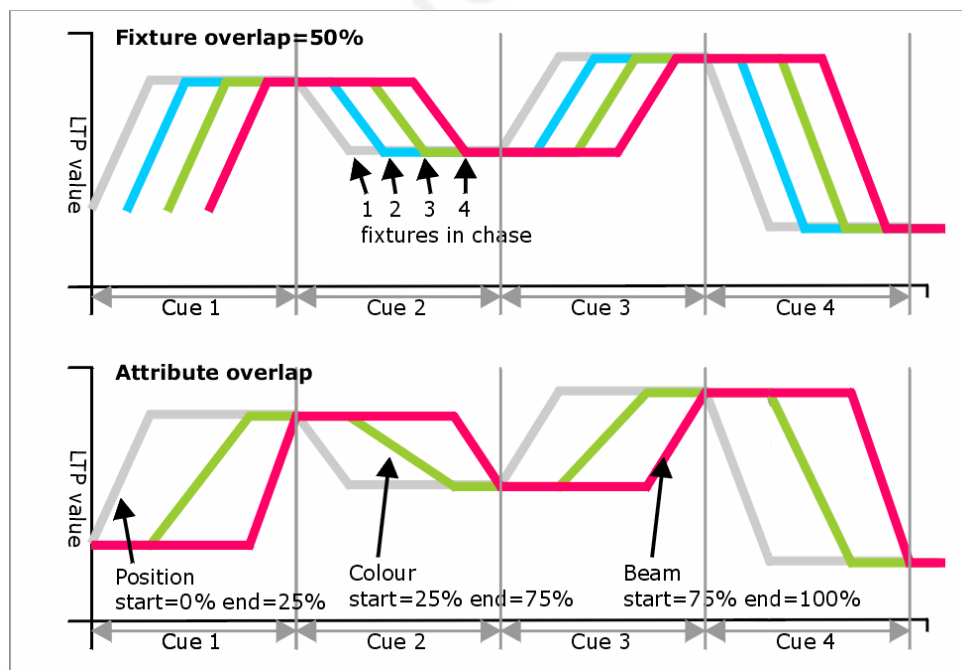

- Press [Fixture Overlap] then enter 0-100 on the keypad to change how fixtures overlap in the cue. 100% (the normal setting) means all fixtures fade together. 0% means that the first fixture will finish its fade before the next one starts giving a “rolling” change across a range of fixtures. 50% means that the 2nd fixture will start fading when the first one is half way through its fade. The order of the fixtures is set by the order you selected them when the cue was saved; you can change the order using Unfold.



From v3 software, [Cue Overlap] is no longer available in chases. Instead use a Cue List set to “Link With Previous” and set the Offset as desired.

8.5.2 Individual cue times in chases

You can configure each cue in a chase to have its own timing information. You can use the Playback View window, or the Unfold function to set individual times for cues in chases.



It is easier to use a Cue List rather than a chase if you need a lot of different timings or link/unlinks. Cue lists are described in the next chapter.

Using the Playback View window:

- 1> *Touch the playback display relating to the fader, or press Window Open then the swop button of the playback. The Playback View window will open.*

	Legend	Delay In	Fade In	Fade Out	Fixture Overlap	Link	View Cue
1	Cue 1	Global	Global	= As In	Global	After Previous	View
2	Cue 2	Global	Global	= As In	Global	After Previous	View
3	Cue 3	Global	Global	= As In	Global	After Previous	View
5	Cue 5	Global	Global	= As In	Global	After Previous	View
6	Cue 6	Global	Global	= As In	Global	After Previous	View
7	Cue 7	Global	Global	= As In	Global	After Previous	View
8	Cue 8	Global	Global	= As In	Global	After Previous	View

- 2> *In the grid, touch the times you want to edit.*
 - 3> *Use the softkey options to change the times or settings.*
 - 4> *Repeat from 2 to change other times or settings.*
- You can change a range of cues all at once by dragging across the grid to select multiple cells, or you can use wheel B to select multiple cells for editing.

Using Unfold:

- 1> *Press the Unfold button, then the Swop button of the chase to be edited.*
- 2> *Press [Edit Times] then the Swop button of the unfolded cue you want to edit.*
- 3> *Set up the timing options as required. The options are described below.*
- 4> *Press Unfold to get out of unfold mode.*

Initially all the timing options are set to Global. You can cancel any individual timings and set the time back to global timings by pressing the softkey for the option then pressing [Use Global].

The timing options for the cue are:

- Delay
- Fade (in)
- Fade Out
- Fixture Overlap
- Linking with previous step
- Attribute times (see next section)

Linking can be set to [Link After Previous] (the chase will run automatically) or [Link Wait For Go] which will stop the chase until you press Go.

8.5.3 Setting attribute fade times for a cue in a chase

For each cue in a chase, you can set individual fade times for each attribute group (such as Position). If you set a time, it overrides the normal times. You can use the Cue View window, or the Unfold function to set attribute times.

To set an attribute group fade time:

-
- 1> Press Window Open or the Unfold button, then the Swop button of the chase to be edited.
 - 2> Press [Edit Times] then touch the cue you want to edit in the Playback View, or if using Unfold, press the Swop button of the unfolded cue you want to edit.
 - 3> Press the Attribute Options button (right hand side) for the attribute you want to change.
 - 4> Press [Delay] to set delay time or [Set fade] to set fade time.
 - 5> Type the new time using the numeric keypad and press Enter to save it, or press [Use Global] to delete the attribute times and go back to the normal times.
 - 6> Press Enter to save the changes.
-

8.6 Advanced options

To set options for a chase, press [Playback Options] on the root menu, then press the swop button of the playback to be edited.

The same options are available as for Cues (see section 7.6 on page 117), with some additional options for Chases:

8.6.1 Loop/Stop on Final Cue

Option B lets you specify whether the chase will loop back to the beginning or stop on the final cue.

8.6.2 Forwards/backwards/bounce/random

Option C sets the direction of the chase.

8.6.3 Cue linking

Option D sets how the cues in the chase are linked. The settings are:

- [Always Link Steps]: The chase will run on its own using the times
- [Never Link Steps]: The chase will pause after every delay/fade time for the user to press Go.
- [Link according to individual steps]: Each step in the chase will obey its individual link settings which are set using the Playback View window or the Unfold function.



When a chase is unlinked, raising the fader does not fire the first cue, which can be a problem. To get round this, if the chase is not looped, simply link the first cue to the previous one. If the chase is looped, add a dummy step at the end with 0sec fade, 0sec delay and link the first step to this one.

8.6.4 Renumber cues

Option [Renumber cues] will renumber all the cues in the chase starting from 1.

9. Cue Lists

Cue Lists allow you to record a sequence of cues, each of which can have its own timings and can be triggered by the Go button or run automatically to the next cue. This allows you to build a complete show in a single list and is ideal for theatrical shows where the show must be exactly the same each time.

Cue lists differ from chases in the way the console handles changes between cues. Chases will crossfade between cues whereas a cue list will track changes.

For example: You record dimmer 1 in cue 1, press clear, record dimmer 2 in cue 2, press clear, record dimmer 3 in cue 3. If this were a chase, when you play it back each cue will fade out the dimmer from the previous cue, as it is not in that cue. Therefore once you get to cue 3, you will only have dimmer 3 active.

Cue lists on the other hand track the cues. This means that the cue list only knows about the changes, so in going from cue 1 to 2 it won't change dimmer 1 as there is no data about dimmer 1 in cue 2. This means that once you get to cue 3, it will have accumulated the data from all the cues and the output will consist of dimmers 1, 2 and 3 together.

If you wanted cue 2 to turn off dimmer 1, you would have to explicitly set the level of dimmer 1 at zero (by selecting it and setting the Intensity to 0); or you can miss out pressing Clear in between saving each cue.

All this means you have to be mindful of what is actually being saved in each cue when you record your cue list.

To view the contents of a cue list, touch the playback screen relating to the fader or press Window Open then the swop button of the

Playback View - Cue List Playbacks[7]												
	Legend	Delay In	Fade In	Delay Out	Fade Out	Fixture Overlap	Link	Link Offset	Preload	Curve	Autoload	Tim
1	Tabwarm	0	2	= As In	= As In	100%	Wait For Go	Disabled	<input type="checkbox"/>	Linear	Load Cue RollerB[3];	23:5
2	Cue 1	0	2	= As In	= As In	100%	Wait For Go	Disabled	<input type="checkbox"/>	Linear		23:5
3	End of scene	0	2	= As In	= As In	100%	Wait For Go	Disabled	<input type="checkbox"/>	Linear		23:5
4	Cue 2	0	2	= As In	= As In	100%	Wait For Go	Disabled	<input type="checkbox"/>	Linear		23:5
5	Cue 5	0	2	= As In	= As In	100%	Wait For Go	Disabled	<input type="checkbox"/>	Linear		23:5
6	Cue 6	0	2	= As In	= As In	100%	Wait For Go	Disabled	<input type="checkbox"/>	Linear		23:5

playback.

9.1 Creating a cue list

9.1.1 Programming a cue-list

Programming a cue list is similar to recording a chase.

You need to set up the look on the stage for each cue and then add it to the cue list. If you want to set fade times, you can either set them while saving the cues or later.

-
- 1> Press Record then [Create Cue List].
 - 2> Press the blue Select button of the playback where you want to store the Cue List (you can also store cue lists in the Playbacks window).
 - 3> Select the Record Mode of the console: by Fixture, Channel, Stage or Quick Build; using [Record Mode Channel] is best as you are sure to only record the attributes you have explicitly set, but you do need to make sure you have changed all the things you want to be recorded so they are in the programmer.
 - 4> Set the default Fade and Delay times, and automatic cue linking, using [Set Times]. These settings will be allocated to every new cue.
 - 5> Set up the look for the first cue, either manually or by using "Include" on existing cues. [Shape Generator] allows you to program shapes.
 - 6> If you require a legend for the cue, set it now using Softkey C. You can also change this later using Unfold or Set Legend (see next section).
 - 7> Press the Select button of the handle or [Append Cue] to store the programmer contents as Cue 1 of the cue list.
 - 8> Repeat from step 5 for the next cue. Do not press Clear in between cues, unless you want levels to track through from previous cues, as any faders moving to zero will not be stored. If you do press clear, you must make sure that all channels you want to record are selected or in the programmer (inverted display).
 - 9> Press Exit to finish when you have stored all the cues you want.
-

- [Record Mode] lets you select Record By Fixture (all attributes of any modified fixture are saved), Record By Channel (only modified attributes are saved), Record Stage (all fixtures with a non-zero dimmer channel are saved) or Quick Build (allows you to build a cue from other playbacks or palettes; select the playbacks/palettes you wish to use and press [OK]).
- Record By Channel is useful if you want to layer this cue list with other playbacks to create an effect.
- You can reopen the cue list to add more cues by repeating the procedure above; this does not affect any cues already stored in the cue list.
- To add more cues to the end of the existing cues press [Append cue].
- To edit an existing cue, press [Cue Number=] and type the cue number to edit. Make the changes then press [Update Cue x].
- To insert new cues, see section 9.3.2.
- The Advanced Options menu allows you to renumber all the cues, and to change the number of an existing cue.
- There is no limit to the number of cues in a cue list.

9.1.2 Changing legends for cues in a cue list

You can set a legend for each cue, which is shown on the screen when running the cue list and can be helpful for keeping track of where you are.

-
- 1> Press [Set Legend] in the top level menu. If you are setting legends for several cues, press Menu Latch to latch the Set Legend menu.
 - 2> Press the Select button of the Cue List.
 - 3> The cues in the cue list are shown on the screen. Use Wheel A to select the cue which is to have a legend set.
 - 5> Press E and type the legend on the keyboard, then press Enter.
 - 6> If you latched the menu, you can continue to set legends for other cues, or press Exit to finish.
-

9.1.3 Autoloading a playback within a cue list

You can program a cue within a cue list to automatically load one or more playbacks when the cue fires. The playback can be a single cue, a chase or another cue list. This can be useful to trigger off chases or effects from the cue list.

You can either automatically save active playbacks as Autoloads, or you can manually allocate Autoloads to cues.

To automatically record active playbacks as Autoloads:

-
- 1> After selecting Cue List Record, turn on [Autoload Live Playbacks] in the [Advanced Options] menu of the cuelist record screen.
 - 2> Turn on the playbacks you wish to load for this cue.
 - 3> Save the cue. Active playbacks will be saved as Autoloads.
-

To manually edit autoloads:

-
- 1> Press [Playback Options] in the top level menu.
 - 2> Press the blue Select button of the Cue List.
 - 3> Press [Autoload].
 - 4> The cues in the cue list are shown on the screen. Use Wheel A to select the cue which is to have the Autoload set.
 - 5> Press the Select button of the playback which is to be loaded. The playback legend appears on the softkeys.
 - 6> You can continue to add Autoloads to other cues, or press Exit to finish.
-

Playback View - Cue List Playbacks[7]												
	Legend	Delay In	Fade In	Delay Out	Fade Out	Fixture Overlap	Link	Link Offset	Preload	Curve	Autoload	Time
1	Tabwarm	0	2	= As In	= As In	100%	Wait For Go	Disabled	<input type="checkbox"/>	Linear	Load Cue RollerB[3];	23:5
2	Cue 1	0	2	= As In	= As In	100%	Wait For Go	Disabled	<input type="checkbox"/>	Linear		23:5
3	End of scene	0	2	= As In	= As In	100%	Wait For Go	Disabled	<input type="checkbox"/>	Linear		23:5
4	Cue 2	0	2	= As In	= As In	100%	Wait For Go	Disabled	<input type="checkbox"/>	Linear		23:5
5	Cue 5	0	2	= As In	= As In	100%	Wait For Go	Disabled	<input type="checkbox"/>	Linear		23:5
6	Cue 6	0	2	= As In	= As In	100%	Wait For Go	Disabled	<input type="checkbox"/>	Linear		23:5

The Autoloaded playback will be fired when the cue starts, and killed when the cue list moves on to the next cue, unless you have also loaded the playback into the next cue.

You can set options for each Autoloaded playback by pressing the softkey where the Autoloaded playback is shown.

For a cue, the only option is [Remove this Autoload].

For a chase or cue list, softkey B lets you select whether to load the playback from the start, to start at a specific cue, or to press Go on the target playback.

9.1.4 Running a key macro from a cue list

You can program a cue within a cue list to trigger a key macro.. This allows you to set up custom actions which can be performed when a cue in a cue list fires; for example you may want to lamp on your fixtures as the first cue in the cue list.

- 1> Press [Playback Options].
- 2> Select the cue list.
- 3> Select [Macros]
- 4> In the Playback View window, select the step you want to add a macro to.
- 5> Press the button(s) for the macro(s) you want to attach to the step. Or press [Add] and choose an action from the list.
- 3> The "Macros" column shows the macros you have added.

- You can remove macros by selecting the cue, pressing the softkey for the macro you wish to remove and then pressing [Remove Link].

9.2 Cue List playback

9.2.1 Running a cue list

Raise the fader of the cue list and press the Go button to run the first cue. The bottom section of the display shows the cue list; the current cue is highlighted in grey and the next cue has a box round it.

Connected Cue List	
Cue List Playbacks[1], 4 steps	
Paused 100%	
1	Cue 1 2s
2	Cue 2 2s
3	Cue 3 2s
4	Cue 4 2s

Also the display relating to the playback fader shows information about the cue list, including the current and next cue, fade progress of the current cue, and fade in/out times.

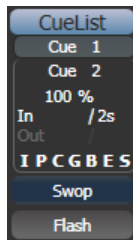

- The HTP levels of cues in the cue list are mastered by the fader level.
- You can pause a fade by pressing the Stop button above the Go button. Press Go again to resume the fade.
- You can skip to any cue in the cue list by selecting a “next” cue using Wheel A, or using the left/right arrow keys. When you press Go, the cue list will run that cue next.
- You can snap back to the previous cue by pressing the Snap Back button
- You can jump directly to a cue by pressing the Connect button, then typing in the desired cue number, then pressing Enter or softkey A. Alternatively at the top level menu you can type the cue number then press Connect.
- You can use Key Profiles to set the blue and grey buttons of the playback to have various functions including Go, Stop, Connect, Next Cue, Prev Cue, Cut Next Cue To Live, and Snap Back.
- When you lower the fader for a cue list, the HTP channels will fade out, but the cue list will remain active. The section below details how to kill the cue list.
- You can use timecode to play back a cue list automatically. See section 9.5.5 on page 140.

9.2.2 Killing a cue list

Once a cue list is fired, it remains active until you kill it. You do this by holding down the Avo Shift button and pressing the blue Select button of the cue list's handle.

You can change this in the Playback Options to make the cue list automatically clear when the fader reaches zero (press [Playback Options] at the program menu, then press the Select button of the cue list, then select [Fader Mode Intensity Kill At 0]).

9.3 Editing cue lists

9.3.1 Editing a cue list using Unfold

The Unfold button places each cue of the cue list on one of the playback faders. This allows you to fire and edit each step individually as if it was a stand-alone cue.

1> Press the Unfold button, then the Select button of the cue list to be edited.

- 2> *The first 10 cues are loaded into the playback faders. The display shows the cue numbers and legends.*
 - 3> *Raise a playback fader to output the contents of that cue (fade times will operate as programmed).*
 - 4> *Various Unfold options are available, the details are below.*
 - 5> *Press Unfold again to get out of unfold mode.*
-

- To edit the contents of a cue: Press Clear to empty the programmer, raise the fader to output the cue, make the changes, press [Record Step], then the Select button for the cue number.
- To change the times or cue linking for the cue, press [Edit Times], then the Select button for the cue, then set the times (see Timing on the following page)
- To Insert a new cue, set up the look for the new cue, press B [Insert Step], then press the playback button where you want the new cue to go. All following cues will be shifted on by one and the new cue will be given a number in between the two existing cues (for example, if you press playback 3, your new cue will be 2.5).
- To Delete a cue, press the blue Delete button then the Select button for the cue you want to delete. Press the Select button again to confirm.
- To change the cue legend, press [Set Step Legend] then the playback select for the step you want to change.
- If the cue list has more cues than there are playback faders, you can swop to the next page using softkeys F and G.

9.3.2 Using Update to change tracked cues

Because fixture settings in a cue list are tracked through from previous cues, if you want to edit a setting you need to find the cue where it was originally set.

The Update function will go back through the cue list from the currently fired cue and automatically update the correct cue.

- 1> *With the cue list fired, select the fixtures and change them to the settings you want to store.*
 - 2> *Press Update.*
 - 3> *Press Enter to immediately store the new values to the cue list. Alternatively, the softkeys show a list of palettes and playbacks which can be updated. Select or deselect these as required.*
 - 4> *If you have used the softkey options, press Enter to complete the update.*
-

- If the attributes you have changed were tracked through from a previous cue, Update will update that cue rather than the current one.

9.3.3 Editing a cue list which is running

You can also edit cues in a cue list while you are running it without using Unfold.

- 1> *Fire the cue list by raising its fader.*

- 2> Use Wheel A to select the cue number you want to change then the Go button to jump to it.
 - 3> Press Clear to make sure the programmer is empty.
 - 4> Make the changes that you want to the current step.
 - 5> Press Record then Connect, then select [Replace], [Merge] or [Insert After] to save the changes (pressing Rec.Step again will select Merge).
 - 6> Press the Go button to jump on to the next step.
-

- You can edit the times for a cue using the Live Time and Next Time buttons as follows:
-

- 1> Fire the cue list by raising its fader.
 - 2> Use Wheel A to select the cue number you want to change then the Go button to jump to it.
 - 3> Press the Live Time button to set the times for the current step, or the Next Time button for the next step. The Live and Next step numbers are shown on the display above the controller wheel.
 - 4> Use the softkeys to set the times, linking and overlap settings you want (see section 7.5.1 on page 113 for description of the times). If you set the [Link to next step] option to On, then the next cue will not wait for the Go button.
 - 5> Press the Go button to jump on to the next step.
-

- The Next Time button allows you to set the time of the next cue without actually running it.
- The Review button lets you test the live step with the new timings.
- You can also use Unfold to set the times as described in the Unfold section above.

9.3.4 Editing a cue list while recording

You can edit cues while you are in the Record Cue List menu.

- 1> Press [Cue Number=x] and type the cue number to be edited.
 - 2> The console will jump to the cue and show the output.
 - 3> Make the changes that you want to the programming of the current step, or to the timings using [Edit Cue x Times].
 - 4> Press [Update Cue x] to save the changes..
-

- You can't change the cue number using this menu – if you press [Cue Number] this will change the cue you are editing. Use [Advanced Options] to change cue numbers.

9.4 Copying, moving, linking and deleting

9.4.1 Copying or moving a cue list

Cue lists can be copied or moved to a new playback, or you can create a linked copy of a playback. Move is useful for tidying up the console.

This operation is exactly the same as for Cues and is described in detail in section 7.4.1 on page 112.

9.4.2 Deleting a cue list

You can delete a whole cue list by pressing Delete then the Select button of the playback to be deleted.

9.4.3 Deleting a cue from a cue list

To delete a single cue from a cue list:

-
- 1> Press the Delete button.
 - 2> Press the Swop button of the cue list.
 - 3> The cues in the cue list are listed on the screen. Use the left hand wheel to select the cue you want to delete, or type in the number of the cue to be deleted.
 - 4> Press [Delete Cue x] to delete the cue.
 - 5> Press [Confirm] to confirm the delete.
-

- Alternatively you can use the Unfold function to delete a cue from a cue list.

9.5 Cue list timing

9.5.1 Time and fade options for Cue Lists

Time settings are independent for each cue in the cue list. The display shows which cue you are working with. You can select which cue is active using Wheel A or softkey A of the Edit Cue List Cue Times menu.

See the diagrams in section 7.5.1 on page 113 and section 8.5.2 on page 126 for more information about overlaps and fade times.

-
- 1> Press A [Edit Times] at the main Program menu then the Swop button of the Cue List.
 - 2> To change which cue you are editing, scroll through the list using Wheel A or press [Cue Number] then type the cue number you want to edit and press Enter. The Chase arrow buttons to the right of the Connect button also step through the cues.
-

- You can select a range of cues, enabling you to alter the timings of multiple cues all in one go, by using Wheel B, or in the Playback View window, dragging across the cues you want to select in the grid.
- To set the delay time before the cue starts once the Go button has been pressed, press [Delay In] then type a time in seconds and press Enter.

- To set the fade in time of the cue, press [Fade In] then type a time in seconds and press Enter. Both HTP and LTP channels are affected by the fade.
- The fade out time of the cue is set by default to be the same as the fade in time. You can change the fade out time by pressing [Fade Out], then type the time in seconds and press Enter. To set equal to Fade In time, delete the time and leave the box blank.
The fade out time starts when the next cue fires, so if you set the time to 1 second, the outgoing cue would start a 1 second fade out as the new cue begins its fade in.
- The Delay Out time of the cue would normally be used if the console links automatically to the next cue, and sets a wait time before the next cue starts its fade in. So the outgoing cue would start to fade out, and the delay out time would run before the new cue begins its fade in.

9.5.2 Cue linking & Link Offset

Cues in cue lists may be linked together, allowing you to build up complex self-timed sequences. The link options are set using the softkeys and are:

- [Link Wait For Go]: the cue waits for the Go button to be pressed then fires immediately. Link Offset is disabled.
- [Link After Previous Cue]: The cue fires when the previous cue has finished its delay in and fade in times. A Link Offset can be set to add a delay between the previous cue finishing and this cue firing. The offset can be given as a time in seconds, or as a percentage of the fade time of the previous cue.
- [Link With Previous Cue]: The cue fires at the same time as the previous cue fires. A Link Offset can be set to add a delay between the previous cue firing and this cue firing, set either in seconds or as a percentage of the fade time of the previous cue.

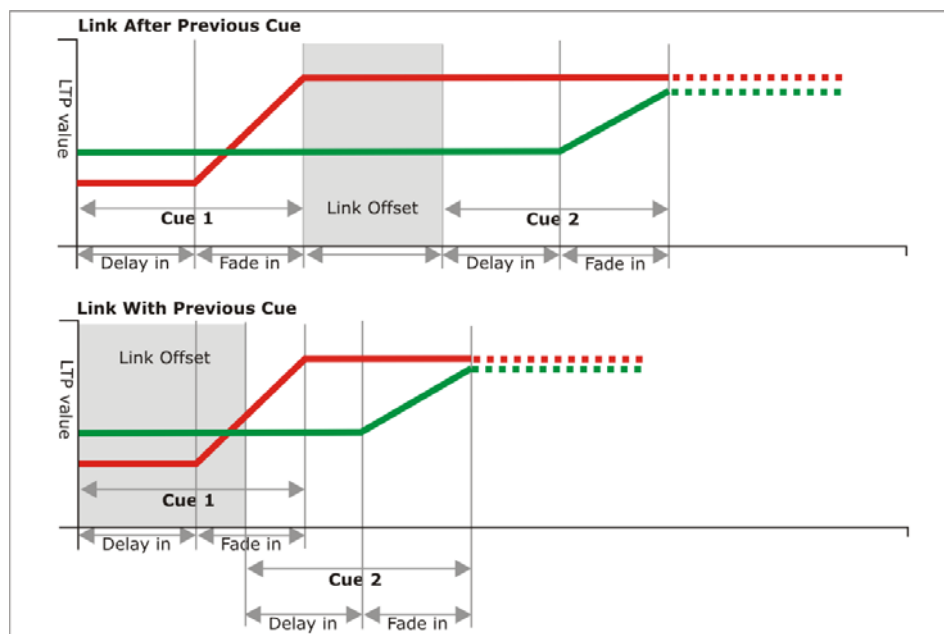

These options allow you to create complex self timed sequences by building up simple steps. For example if you wanted the following effect:

- Go is pressed, Fixture one starts fading up over 20s
- After 10s Fixture two fades up over 15s
- Both lights stay on for 5s
- Both lights go off in 3s

You could program

- Cue 1 - Fixture 1 @ 100%, Fade In 20s, Link Wait For Go
- Cue 2 - Fixture 2 @ 100%, Fade In 15s, Link With Previous, Link Offset 10s
- Cue 3 - Fixture 1 AND 2 @ 0%, Fade Out 3s, Link After Previous, Link Offset 5s



To obtain the effect which was called "cue overlap" in previous versions of software, use [Link With Previous Cue] and set a percentage Link Offset time. Link Offset of 100% is equivalent to Cue Overlap of 0% and vice versa.

9.5.3 Individual attribute fade times

You can set individual fade times for each IPCGBES attribute group. You can also select which fixtures this is applied to. For example you can make the position change take 2 seconds, but the colour change take 10 seconds.

Additionally you can set individual times for each attribute so you could make the pan fade over a different time to the tilt.

To set times for an attribute group, first select the Set Times menu and go to the cue you want to set as described above, then press G [Next] to go to the second page of options.

1> Press C [Attribute times].

- 2> All fixtures in the cue will be selected. If you don't want to change the times for any fixtures, deselect them now. You can press the ALL button (below Next Time) to select all fixtures in the cue or Shift+ALL to deselect all fixtures.
- 3> Press the softkey for the attribute group you want to change.
- 4> Press A [Delay] to set the delay time, or press B [Fade] to set the fade time. Press G [Use global] to remove the attribute group timing and go back to the normal delay/fade times for the cue.

- You can use [Individual Attributes] to set times for one attribute within the group, for example just Pan from within the Position group. You can also use the Cue View window to set times for individual attributes.

9.5.4 Fixture overlap

For each cue you can set a (linked together) fixture overlap, which causes Titan Mobile to apply the settings in the cue to each fixture sequentially giving a "rolling" change across the fixtures in the cue. This can create some great effects without much programming on your part.

- Press A [Fixture Overlap] (on the second page of the Cue Times menu) then enter 0-100 on the keypad to change how fixtures overlap in the cue. 100% means all fixtures fade together (the normal setting). 0% means that the first fixture will finish its fade before the next one starts. 50% means that the 2nd fixture will start fading when the first one is half way through its fade.
- To change the fixture order when using overlap, press D [Set Fixture Order]. Normally this is the order in which you selected the fixtures when you programmed the cue. The Fixture window shows the fixture order in large green numbers. Reorder the fixtures by pressing A [Step Number] then type the start number on the numeric keys, then press the fixture Select buttons in the order you want them. For example, to set the order of 8 fixtures, press 1 on the keypad, then press the Select button of the fixture to be first, then the Select button for the second, and so on. You can set several fixtures to the same number if you want them to change simultaneously. If you press a fixture button twice, it will show X and be excluded from the sequence.

Press Exit to finish setting the fixture order.



9.5.5 Running a cue list to timecode

The console can run a cue list automatically to a timecode. This is very useful for complex performances which must be exactly the same time after time, or for unattended operation. Each step in the cue list is assigned a time at which it will run.

The timecode can be read from the system clock, from an internal timecode source, from MIDI or from Winamp. Internal timecode is useful for programming a sequence which will later be triggered by an external timecode source.

-
- 1> *Connect the cue list for which you want to set timecode.*
 - 2> *Press [Timecode] on the top-level menu.*
 - 3> *Press Softkey A to select the desired timecode source.*
 - 4> *Press [Record].*
 - 5> *Start the timecode source. If using internal timecode, press [Play] to start it.*
 - 5> *Press the red Go button to step each cue at the time you wish the cue to start.*
 - 6> *Press [Record] when you have finished.*
-

To play back a timecoded cue list, press [Connected Cue Lists] and select the cue list which is to be played. Then press [Timer ...] to enable the timecode input.

When you start the timecode source (or press [Play] if using internal timecode), each cue will fire as the timecode matches its programmed time.

You can edit the timecode for each cue by using Wheel A to select the cue, then press Enter and type the new timecode for the cue.

Cue	Curve	Autoload	Timecode	Notes	View
	Linear		00:00:00.24		View
	Linear		00:09:00.00		View
	Linear		00:12:00.00		View
	Linear		00:25:00.24		View
	Linear		23:59:59.24		View
	Linear		23:59:59.24		View

While editing a time you can also use Wheel B to select multiple cues, and use the softkey options to enter a value to change the time of all the cues (offset, add a fixed time or subtract a fixed time).

You can open a timecode display window to show you the incoming timecode – press [Open Workspace Window] then [Timecode].

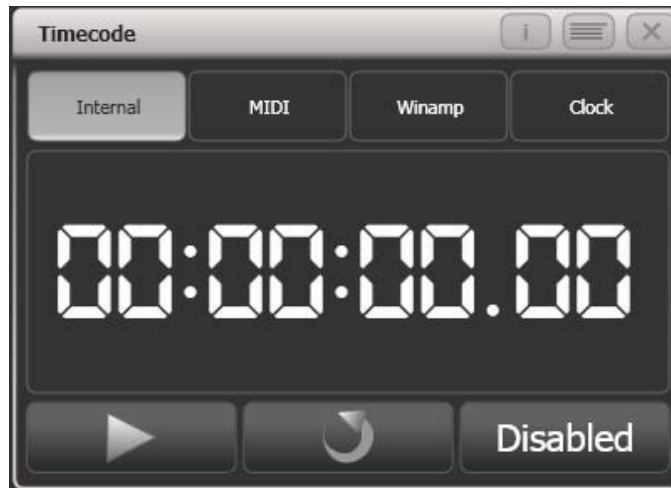

9.6 Advanced options

Advanced cue list options are set from the Playback Options menu. You can enter the playback options menu by doing the following

-
- 1> *At the top level menu press [Playback Options].*
 - 2> *Press the select button for the cue list you wish to edit.*
-

9.6.1 Release mask

[Release Mask] lets you specify using the softkeys which attributes will be released back to their state in other live playbacks when the playback is killed. You can also use the Attribute Bank buttons on the right side of the console to set the mask. The default setting is to not release any attributes.

9.6.2 Fader mode

This option sets how the cue list fader behaves. If set to [Fader Mode Intensity Kill With Off], the fader masters the overall HTP level and the cue list remains active (connected) even when the fader is lowered to zero. If set to [Fader Mode Intensity Kill At 0], the fader masters the overall HTP level and the cue list is killed when the fader is lowered to zero. If set to [Manual Crossfader] the fader behaves as a manual crossfade control, and the cue list will automatically step on to the next cue when the fader reaches the top or bottom of travel.

9.6.3 Handle Paging

This option allows you to lock the playback on a handle so that it always appears on that handle no matter what page is selected.

If you select "Transparent Lock" then the playback will appear on the current page if no other playback is programmed in that position.

9.6.4 Cue Options

This option allows you to change settings for each cue in the cue list. To select the cue number to edit, use the left hand wheel or press softkey A then enter the cue number on the numeric keypad.

- [Curve] allows you to set a different fade curve for the cue; this affects how the fade progresses from one cue to the other (for example you can select a fade which starts off slow, speeds up in the middle and then slows down at the end). Press [Curve] then select a new curve from the softkeys. The effect of the various curves is described in section 12.5 on page 163.
- [Link] can be set to Press Go, With Previous Cue or After Previous Cue. See section 9.5.2 on page 137.
- [Preload] allows you to make this cue load the LTP values from the next cue within the cue list (for example to pre-position some fixtures for an effect).
- [Legend] allows you to set a legend for the cue which is displayed on the cue list display.
- [Notes=] lets you enter a note for the cue (“Leaves stage pursued by bear” or “wake up spot operator”).

9.6.5 Autoload

This option allows you to automatically load a playback with a cue and is described in section 9.1.3 on page 131.

9.6.6 Macro Links

You can link a key macro to each cue un a cue list. See 9.1.4 on page 132.

9.6.7 Key Profile

Each playback can have an individual Key Profile allocated to it. This allows you to customise the panel button functions differently for each playback. A list of available Key Profiles is shown, or you can add a new one. The softkeys show the function allocated to the blue and grey buttons for each of the available Key Profiles.

If the playback Key Profile is set to “None”, the default global profile is used.

9.6.8 Shape Size/Shape Speed

These options allow you to set whether shapes in the cue list are replayed at fixed size/speed, or whether this should be set by the playback fader position.

9.6.9 Tracking

Tracking mode (where each cue depends on the state of the previous cue) may be disabled using this option.

10. Running the show

So, it's showtime. This chapter describes the functions of the console which are useful when running a show.

10.1 Playback controls

10.1.1 Back up the show

At regular intervals while you are programming, and when you have finished programming (or you've run out of time) and it's showtime, the most important thing is to back up the show to USB pen drive or the internal disk (see section 2.3.5 on page 26 for instructions).

10.1.2 Label the console

When you are running your show you will need to know where everything is. Use the Legend functions to set onscreen labels, or you can't beat the low tech method of marker pen and tape.

Program

10.1.3 Flash and swop buttons

The Flash and Swop buttons on the playback faders may be used at any time to flash and solo cues and chases. The Flash button adds the playback into the current output, the Swop button turns off all other output.

You can reallocate the functions of the Flash and Swop/Select buttons on the console using Key Profiles – see section 12.3.4 on page 161. A useful alternative function is Preload which allows you to preset the attributes of the fixtures before you raise the playback fader, which is handy for avoiding unwanted movements (any fixtures which are already active in another playback will not change when you use Preload). You can also allocate Go and Stop buttons for cue lists and chases. To quickly change the key profile, hold Avo Shift and press [Edit Key Profile].

The screen relating to each playback faders shows the allocated function of the blue and grey buttons.



10.1.4 Playback priority

You can set playbacks to high priority if you do not want them to be overridden by other playbacks using the same fixtures. For example, if you have a couple of fixtures acting as a spotlight, but they are also programmed into some colour washes, you probably want the spotlight cue to take priority over the colour washes. See section 7.6.5 on page 117.

10.1.5 Blind mode

You can set the console to Blind mode by holding down the Avo button and selecting [Blind]. This allows you to program cues using the visualiser window without affecting the look on the stage.

10.1.6 Manual control during a show (“busking”)

If you have not had as much programming time as you would have liked, you might need to make up some additional effects during the show. This is sometimes called “busking”, and is where the fun starts!

You can create instant variations by recalling palette values to modify your existing cues. The console can fade to the palette values for added effect.

-
- 1> *Select some fixtures which are already in use on stage..*
 - 2> *Type “2” (or any time, in seconds) on the numeric keypad.*
 - 3> *Touch a Palette button to recall a palette.*
 - 4> *The selected fixtures will change to the new palette over a time of 2 seconds.*
-

When a fade is entered, you can also change the “Fixture Overlap” using softkey A. This allows you to create “roll” or “peel” effects when using a series of fixtures. With overlap=100%, all fixtures change at the same time. If overlap=50%, the second fixture will not start its fade until the first fixture is half way (50%) through fading. The order of the fixtures is set by the order in which you selected them.

The palette fade time remains active while the Palette Fade menu is open. Press Exit to leave the menu and return to instant palette recall.

If you apply a palette with a fade time, then it will be overridden by the next cue (so if you fade to green using a palette, then fire a cue which sets those fixtures blue, they will go blue). If you apply a palette without a fade time, it will go into the programmer and override any subsequent cues (so if you use a green palette with no fade, the fixtures will be locked in green until you press Clear).

Having the palette overridden by the next cue is quite useful when “busking”. If you need to “snap” a palette but still have it overridden by the next cue, set a fade time of 0 (leaving the Palette fade menu open).

When programming your palettes, group all the colour palettes in one area of the console, position palettes in another area, and so on. This helps you to find them when the show is running and the pressure is on.

If you are lighting a band, make position palettes for every person on stage so you can spotlight them for those unplanned solos.

You can use the Off function (see section 7.3.5 on page 111) when programming to set some cues to only affect position, and other cues to set colours, gobos, add shapes, and so on. By combining two or more cues you can produce a much wider range of effects than if all your cues set all the attributes. However, for this to work well you need to make sure you know what attribute is going to be affected by each cue; as if you fire two “colour only” cues then nothing is going to light up.

10.2 Using multiple on-screen workspaces

On the screen you can configure different “workspaces” which store how the various windows are displayed. This allows you to quickly recall different setups. Workspaces are stored and recalled from the touch buttons to the left of the menu buttons.

10.2.1 View menu

Pressing Window Open (by numeric keys) takes you into the View menu. From here you can set up what is shown on the screen.

- [Window Options] allows you to reposition and resize windows.
- [Open Workspace Window] allows you to open and close all the possible windows.

10.3 Organising the console

If the layout of the fixture buttons, palettes or playbacks has become a bit mixed up during programming, you can use the Move function to move recorded items around and produce a better layout. When an item is moved, all links to other recorded items are retained.

10.3.1 Using the Move function

To move fixtures, palettes, groups and playbacks is very simple.

-
- 1> Press Avo and the Copy button to select Move mode.
 - 2> Press or touch the select key(s) of the item(s) to move.
 - 3> Press or touch the select key of the destination.
-

When moving a range, it is possible to select a range containing different types of items, and there can be gaps between them. In this case, you can set option B to [Bunch Up] to have all of the gaps in the range removed.

[Swap Items if Required] will attempt to reposition any existing handles which are in the way of the move. This is useful when rearranging handles on a page which is nearly full.

- If there is not enough space, (there is an item in the way or there is not enough space before the end of the page) then the action will not be completed.

10.4 MIDI remote triggering

You can set up the console to allow most features to be triggered by external events. This is very useful in complex shows or when using in an automated setup.

10.4.1 Connecting remote trigger sources

To connect a MIDI source, connect it to the MIDI in connector on the console.

10.4.2 Setting up remote triggering

Enter System mode and select [Triggers]. The Triggers window will open.

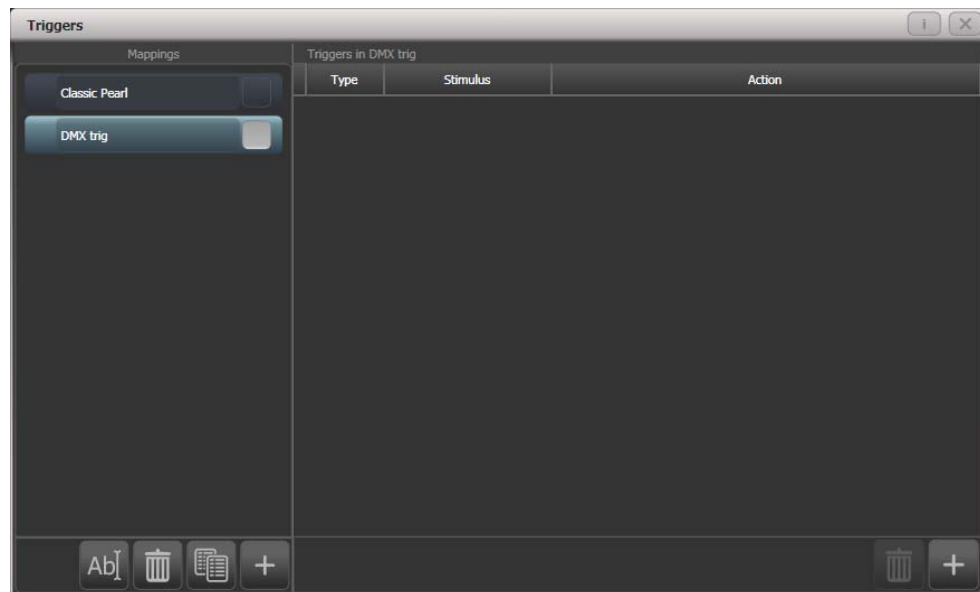

The left hand side of the window has a list of trigger sets. The “classic Pearl” MIDI trigger implementation is provided as one of these. Each set of triggers can be enabled or disabled using the button at the right hand end of the mapping name.

- 1> Add a new mapping using the + button at the bottom of the left hand column, and enter a name for it.
- 2> Add a trigger to the mapping using the + button in the right hand column or softkey [Add trigger].
- 3> Select [Trigger Type] as [Hardware] to trigger a physical button press or fader move, or [Item] to trigger a screen button (playback, fixture, palette, group or macro).
- 4> Press the button or move the fader to be triggered. The screen will update to show you what has been triggered. For Item triggers you can select different actions using the [Action] softkey.
- 5> Press [OK]. You have now set up the console action which is to be triggered.
- 6> Now you need to set up the external stimulus which will cause the trigger. Select [Trigger Type] as MIDI.
- 8> Generate the stimulus from your device (for example play the MIDI note). If the [Learn] option is set to On, the console will automatically detect the stimulus. Or you can enter the details using the softkey options.
- 9> For MIDI triggers you can select MIDI channel, Midi Command, Value, and Level (velocity) ranges.
- 10> Press [Add] to add the trigger to the list.
- 11> The window will show the trigger stimulus and the action to be carried out.

You can continue to add other triggers to the mapping.

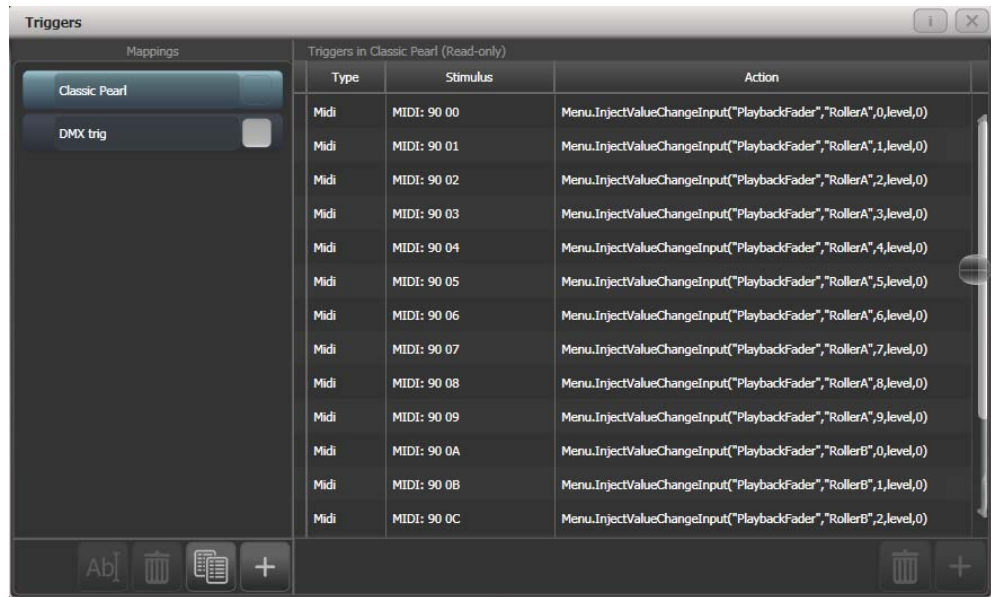

To delete a trigger from the mapping, select it in the list and press the rubbish bin button at the bottom.

To delete a complete mapping, select it and press the rubbish bin button at the bottom of the left hand column.

10.4.3 Classic Pearl MIDI triggers

This trigger map sets up the console to mimic the MIDI setup of the classic Pearl software. It is used for triggering playbacks from MIDI.

Set playback page : *program change (\$Cn xx)*

Page	1	2	3	4	5	...	28	29	30
xx	\$00	\$01	\$02	\$03	\$04	...	\$1B	\$1C	\$1D

example \$Cn \$02 Console changes to Page 3

Turn on a playback: *note on (\$9n pp ll)*

Note number (pp) = playback number, from 0 - 14 (decimal)

Key velocity (ll) = playback level, from 0 - 127 (decimal). 127=Full

example \$9n \$03 \$40 Playback Fader 4 at 50% level.

(Note that Playback Fader numbers start at zero, so subtract one from the number on the console to get the MIDI note number).

To Turn Off a playback, send a note on command with velocity=0. The console does not recognise MIDI note off (\$8n) commands.

Stop/run/step a chase etc: *after touch (\$An pp cc)*

Note number (pp) = playback number, from 0 - 19 (decimal)

Aftertouch value (cc) = control codes:

\$00 stop chase
 \$01 run chase
 \$02 restart from step 1

- \$03 fade to next step using programmed fade times
- \$04 Snap directly to next step

Copyright Avolites 2011

11. Remote control

With the addition of an external Wireless Access Point, the console can be remote controlled using Wi-Fi from a mobile internet device. This can be invaluable when rigging, testing and focusing. You can also run playbacks and reset fixtures from the remote.

The remote function operates from a web page on the console which is accessed using the web browser in the mobile device.



11.1 Setting up the remote

This is a basic setup assuming that the console is connected directly to an access point. For more complicated networks, please consult your network administrator. For information on setting up your Wireless Access Point please refer to the documentation provided with it.

11.1.1 Network setup

You need to set up the network settings on the Wireless Access Point, the mobile device and the console so that they can communicate with each other. In this example we use an iPod touch but other devices are similar.

- 1> Give the access point an IP address such as 192.168.0.1.
- 2> Make sure wireless is switched on.
- 3> Take note of the name of the wireless network (SSID).
- 4> Connect an Ethernet cable from the back of the console to the access point.
- 5> Set the IP address of the console: Switch to System, select [Network Settings], press [Local Area Connection], then press [IP Address] and change the IP address to 192.168.0.2. press [Save Settings] to store it.
- 6> On the mobile device, go to WiFi settings or Network Settings.
- 7> Ensure Wi-Fi is set to on.
- 8> Select the wireless network from the list, the name you took note of earlier.
- 9> Select the network name to change settings for that network:



Select *Static*, type in an IP address such as 192.168.0.3 and type in a subnet mask 255.255.255.0. Finally exit the settings.

- 10> Test that the mobile device is connected to the console: From the Avolites toolbar on the console, open Command Prompt. Type in "ping 192.168.0.3" and then press return. If it displays "Reply from 192.168.0.3" then the test was successful.



11.1.2 Console setup

Now you need to set the console to allow connections from the remote device. This prevents members of the audience from taking over control of the console!

1. On the console, switch to System and press [AvoTalk Security] then [Remotes]. Press the softkey A toggle until it reads "Allow All Remotes".
2. Connect to the console from the mobile device by opening the web browser and typing in the address: `http://192.168.0.2/Remote/` (where "192.168.0.2" is the IP address of the console which you set earlier).
3. Choose a user name and type that into the box on the mobile device and press Create.
4. The console will notify the operator of the remote request showing the user name you provided. The operator then chooses whether to allow or deny the remote.
5. The console provides a 5 digit key which needs to be typed into the iPod to pair the remote. Steps 3, 4 and 5 only need to be done the first time a mobile device is connected; the remote will connect automatically from then onwards.
6. The remote is now ready to control the lights patched on the console.

The options on the Remote menu Softkey A are:

- Remotes Disabled - No commands will be accepted from paired remotes, new pair requests will be ignored.
- Allow Paired Remotes - Only allow commands from previously paired remotes, new pair requests will be ignored.
- Allow New Remotes - Allow previously paired remotes and display pair requests to the user for confirmation.
- Allow All Remotes - For the current version of the remote this is roughly equivalent to the previous option.

Pair requests will only be displayed when in System and Program modes and when one of the last 2 options is selected.

At showtime, you should select one of the first 2 options to ensure you don't get any interruptions.

The Remote menu shows a list of paired remotes on the softkeys. Selecting a remote gives you the option to temporarily disable that remote or to delete it from the system.

11.2 Operating the remote

To connect to the console, open the web browser and type in the address of the console; if set up as described above this will be: <http://192.168.0.2/Remote/>

The remote screen always shows a header with a view selector, to choose which options to view, and a clear button.



11.2.1 Keypad

The keypad screen lets you do most common tasks. You can turn on/Locate fixtures and dimmers either singly or together, and a further screen allows macros.

The User Number of the fixture or dimmer is used for control. For example to turn on dimmer 3 at 50% you would press:

3@5

To turn on dimmers 1-10 at 80% you would press:

1 Thru 10 @ 8

For 100% you just press @ twice, for example

1 Thru 10 @ @

To locate one or more fixtures, press Locate instead of the @ button. You can select multiple ranges of dimmers or fixtures using the And button, for example *1 Thru 10 And 20 Thru 30 @ 6*.

The More button allows further commands on the selected dimmers of fixtures. For example to turn On the dimmers at the level set in the User Preferences you would press

1 Thru 10 More On

There is also a Locate No Pan and Tilt option on the More screen which turns on a fixture but does not change its position.

The Macro button allows you to operate setup features of fixtures such as Reset, Lamp On, Lamp Off.

To operate macro functions, select the required fixtures, then press More, then Macro, then press the macro function you want.

For example to reset fixtures 1 to 10 you

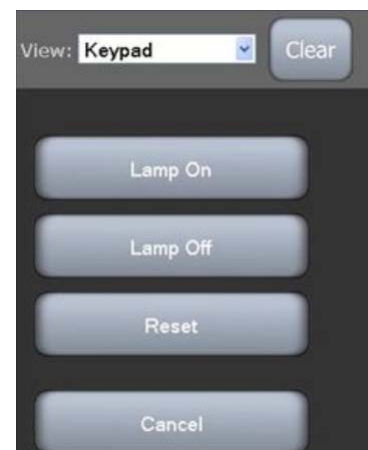

would press

1 Thru 10 More Macro Reset

11.2.2 Fixture List

The fixture list view shows you all the fixtures in a familiar spreadsheet style, including the user number, fixture type, DMX address and legend. A drop down "Action" list sets an action which will be activated when you select a fixture.

For example if the action is set to Locate, pressing a fixture once will locate it, and pressing the same fixture again will switch it off again (dimmer at 0%).

The All button selects all fixtures, or click on a fixture in the list to select it. When using "all fixtures" you need to click OK to carry out an action.

You can alter the sort order of the list by clicking a column header. An arrow indicates which is the current sort column (the leftmost column, User Number, in the picture). To reverse the sort order, click the column header again.

Fixtures in the Programmer are highlighted in Blue. Fixtures in the Editor are highlighted in Cyan.

You can filter fixtures using the Legend text by typing text into the Filter box. For example typing "drum" into the filter box would show only fixtures 14 and 13.

The dropdown box above the fixture type allows you to filter the list to only that type of fixture as shown in the picture.

11.2.3 Playback List

The playback list view shows you all the playbacks including the playback type and legend. A drop down list allows you to carry out actions on the playbacks including "on @ level" (for example Full, or 50%), and "Off". Once the action is selected, pressing a playback in the list will immediately perform the action.

#	All	DMX	Legend
14	Mac 250 Wash	A88	Drums R
13	Mac 250 Wash	A69	Drums L
12	MAC 500	A53	USC
11	MAC 500	A37	Centrspec
10	MAC 600	A23	DSR
9	MAC 600	A9	DSL
8	Dimmer	A8	Dim

#	MAC 500	DMX	Legend
11	MAC 500	A37	Centrspec
12	MAC 500	A53	USC

All	Legend	Back	Go
Cue	Blu Bax		
Chase	Mad Aeros		
CueList	Predict riot	⬇️	⬆️
Cue	Red Cyc		
Cue	Riot Base		

Again you can sort and filter the playbacks using the Filter box to filter by legend, or the column headers.

The "Back" and "Go" buttons are used for CueLists which will be enabled in a future software release.

11.2.4 Settings screen

The Settings screen allows you to configure the On level and other options for the operation of the remote.

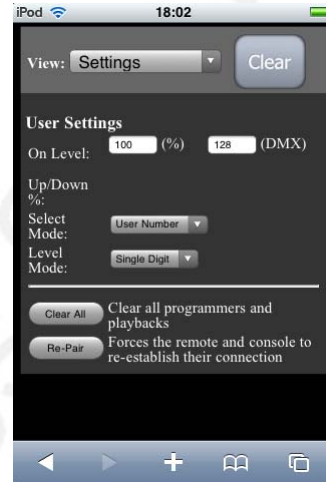

11.3 Troubleshooting

If you have problems setting up the remote, try the following steps:

Try connecting locally on the console by typing "http://localhost/remote" into Windows Explorer address bar. This should display the remote screen.

Open Command Prompt on the console and ping the IP address of the iPod as described in step 10 of Network setup.

Clear cookies and cache on the mobile device.

Delete remotes from the list on the console (System > AvoTalk Security > Remotes)

Choose "Restart Titan Remote" from the additional programs menu on the shell.

Copyright Avolites 2011

12. User Settings and other options

The console has a large number of options to help you set it up just the way you like it. Commonly used options can be set from the User Settings menu which is available on a softkey when you hold down the Avo button.

In this chapter there is also information on how to upgrade the application software.

12.1 Configuring the Workspace

The main area of the screen can each show up to 4 workspace windows. Workspaces can be saved to a touch button and called back immediately.

Some windows have associated touch buttons, when the window is active these are shown in the "context buttons" area on the right of the screen.

12.1.1 Opening workspace windows

You select which workspace windows you want to see using the [Open Workspace Window] menu command on the root menu or the View menu, or by pressing the appropriate Window Selection button.

12.1.2 Selecting and positioning workspace windows

To change the position of a workspace window you first make it active by touching its header bar.

i You can change the positions and sizes of the active window by using the Window Control buttons above the numeric keypad or touch the i

Some possible window sizes/positions are shown below.



Quarter size



Double wide



Double height



Maximised

You can close the active window using the Close button. You can close all windows by pressing Avo+Close, or use the [Close All] softkey.

12.1.3 Saving workspaces

You can save different workspace setups to the Workspaces touch buttons (to the left of the menu) by pressing Window Open then [Record Workspace], then touching one of the Workspaces buttons. This allows you to reconfigure the entire workspace with the touch of one button.

Workspaces are saved with the show.

As an example of setting up a workspace, suppose while programming you wanted to be able to access fixtures, position palettes, fixture attributes and shapes:

- 1> Press Exit to get to the root menu then the [Open Workspace Window] menu softkey.
- 2> Find the [Fixtures] window in the list and press it.
- 3> If the window is not in the top left quarter, press the Size & Position button (above the numeric keys) until the window occupies the top left quarter
- 4> Press [Open Workspace Window] again and select the [Positions] window. Press the Size & Position button to position it in the desired location.
- 5> Repeat to activate the [Attribute Control] and [Shapes] windows.
- 6> Press Window Open (to the right of the numeric keys) then [Record Workspace], or hold Avo and press View. Type in a name for the workspace. Then touch the Workspace button where you want to store this workspace layout. Or, you can use Quick Record – just touch an empty workspace button and it will turn red with a +. Type a name for the workspace and touch again to store it.

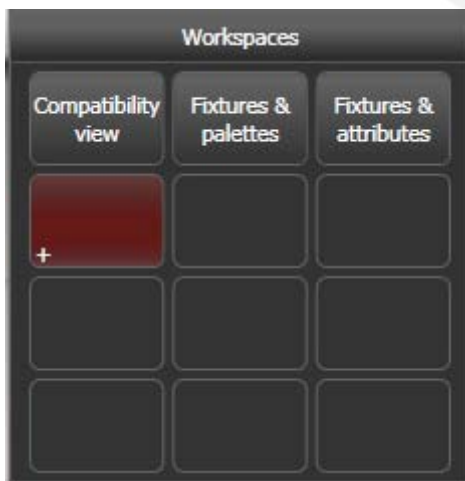

- [Record Visible/All Windows] lets you set whether the workspace will contain only the windows which are currently visible, or will also include any windows which are hidden underneath other windows.
- [Remove/Leave other windows on recall] sets whether all other windows will be closed when this workspace is recalled.
- To delete a workspace button, press Window Open, Delete, then the workspace button to be deleted.

12.1.4 Compatibility view

This workspace shows the “blue and grey handle” view which was used in version 2.x of the Tiger Touch software, and which also allows you to access the preset fader handles in shows which have been programmed on the Pearl Expert.

When the compatibility view is opened, there is a context button option to [Move to workspace]. This will move the handles from the compatibility window to the appropriate workspace window. You need to do this twice, once with the "Fixtures and playbacks" window selected, and once with the "Palettes and groups" window selected.

12.2 Key Profiles

The console allows you to reconfigure how the front panel buttons work to suit your method of working. You can save your settings as a Key Profile. Different profiles can be selected for different users or to enhance the operation of the console for a particular use.

There are standard Key Profiles for Run mode, Takeover Run mode and Program mode. These standard profiles cannot be edited, so you always know how they will behave. You can create your own editable profiles using one of the standard profiles as a starting point.

The current settings of the playback buttons are shown on the screen related to each playback fader.



12.2.1 Creating and editing key profiles

To create or edit a profile, switch to System mode then select [Key Profiles]. You can then use the Manage Profiles menu to View, Edit, Add, Delete or Rename profiles.

When Adding a new profile, you can select an existing profile to copy settings from.

You can also edit Key Profiles from Program mode by holding Avo, then selecting [Edit Current Key Profile]. If the current key profile is one of the non-editable system ones, you are prompted to add a new profile or select an existing editable profile.

The current settings for the [blue], [grey] and (where available), [touch] buttons are shown on the left side of the screen.



The groups of keys you can set are as follows. The blue or grey fixture/palette buttons only exist on the Pearl Expert, on other consoles these settings will not do anything.

Fixtures: the blue, grey or touch key can be allocated to Disabled, Select, Flash, Swop, Latch. The “Latch” function is equivalent to putting the fader to full for that fixture and touching again returns the fader to 0.

Palettes: the palette (grey) key can be allocated to Disabled, Select Palette. You can select if the palette function takes precedence over the flash function (if a handle has both palette and flash functions) or vice versa.

Groups: the group (grey) key can be allocated to Disabled, Select Group. You can select if the group function takes precedence over the flash function (if a handle has both group and flash functions) or vice versa.

Cues: the blue or grey key can be allocated to Disabled, Flash, Swop, Latch, Preload.

Chases: the blue or grey key can be allocated to Disabled, Flash, Swop, Latch, Go, Stop, Preload, Connect, Tap Tempo.

Cue Lists: the blue or grey key can be allocated to Disabled, Flash, Swop, Go, Go Back, Stop, Preload, Connect, Next Cue +, Next Cue -, Review Live Cue, Cut Next Cue To Live, Snap Back.

Macros: can be set to Select or Prefer Macro (the Macro function will take precedence over other functions stored on the button).

Quick Record: allows you to disable the quick record function.

12.2.2 Selecting a key profile

To quickly select a Key Profile, hold the Avo Shift button and press [Select Key Profile].

12.2.3 Individual Key profiles for playbacks

Each playback can have an individual Key Profile allocated to it. This allows you to customise the panel button functions differently for each playback. The Key Profile for the playback is selected using the [Key Profile] option on the Playback Options menu (Softkey B on the main program menu). If the playback Key Profile is set to "None", the default global profile is used.

Copyright Avolites 2011

12.3 The System menu

The System menu is accessed by switching the console to System mode by holding Avo and pressing Shift/System. The options in this menu are separated from the other options on the console because you would normally only change them occasionally, or because they can have serious effects on the way the console works and you wouldn't want to change them accidentally.



When the console is in System mode, playback control, preset controls and programming buttons are all disabled.

12.3.1 Avotalk Security

This option sets how the console communicates with other network devices such as wifi remotes. See section 11.1 for information about Remotes.

12.3.2 Network Settings

This option sets up networking (Ethernet) parameters for the console. See section 14 for details.

12.3.3 User Settings

The User Settings menu may also be accessed from Program mode: hold down the Avo Shift button and press [User Settings].

There are several pages of options and the bottom two softkeys go through the different pages.

- [Grand Master...] sets whether the Grand Master fader is enabled or disabled. This can be handy if it gets broken! Has no effect if the console has no Grand Master.
- [Prompt for Merge or Replace...] sets the console action when you try to save to a handle or playback which is already used. The options are [Prompt for Merge or Replace] - the console will always prompt, [Always Merge] - the console will never prompt or [Palettes Always Merge] - the console will prompt unless you are saving a palette.
- [Warn before parking fixtures ...] sets the console action when you patch a fixture which overwrites the DMX channels of another fixture. This causes the overwritten fixture to be "parked" The options are [Always] (console will warn you) and [Never] (console will park the fixture without warning you).
- [Tempo Units...] sets the units for displaying tempo. The options are [Beats per Minute] or [Seconds].
- [Connected View ... Chase Speed] sets the console action when you change the speed of a connected chase. [Connected View Sets Temporary Chase Speed] means that the console will not save the modified speed, and the next time the chase is fired it will go back to its programmed speed. [Connected View Sets Chase Speed] means that the console will modify the saved speed of the chase.

- [Auto Connect...] sets whether Chases and Cue Lists will auto-connect to the wheels when the playback is fired. The options are [Off], [Chases], [Lists] and [Chases and Lists].
- [Channel Levels...] sets how you enter channel levels when using numeric entry of levels. If set to [Channel Levels Set In Tens], you enter one digit for the channel level (e.g. 5 = 50%). If set to [Channel Levels Set in Units] you enter two digits, i.e. 50 = 50%.
- [Preload Time] sets a fade time for the Preload function, normally 2 seconds. This value would normally be set for quiet fixture movement.
- [Quick Palettes] enables or disables the Quick Palette function. See section 5.2.3.
- [Press and Hold Fan] changes the Fan function so that it only works while the Fan button is held. This avoids the common user error of leaving Fan turned on accidentally.
- [Key Profiles] accesses the key profiles menu which can also be found on the System menu. The option is also found here so that you can access it using the Avo Shift button. See section 12.2.
- [LED Levels] sets the behaviour of the LEDs in the Select buttons. This option only works on the Pearl Expert.
- [Timecode] This option lets you select the settings for glitch detection, tolerance and timeout when using MIDI timecode.
- [Wheel sensitivity] The sensitivity of the encoder wheels, and the pan/tilt threshold settings can be adjusted using this option. Wheel sensitivity is adjusted using Wheel A and the current level is shown on the display.
- [Add New Palette Channels to Playbacks] sets whether new channels added into palettes will be added to playbacks using those palettes.
- [Auto Groups] sets whether the console will automatically create new groups for fixtures when you patch.
- [Handle Buttons] lets you set the size of the touch buttons to [Small], [Normal], [Large] or [Super Size].
- [Text Size] allows you to set the size of the text used in touch buttons.

12.3.4 Key Profiles

Allows you to modify the functions of some buttons. See section 12.2.

12.3.5 Wipe

The Wipe menu erases the current show. This is the same as the [New Show] option on the Disk menu, but is provided here for experienced Avolites users who are used to it being on the System menu.

The [Wipe Visualiser Patch] option will erase all fixtures from the visualiser without affecting the current show.

12.3.6 Display Setup

This option gives you a menu for enabling and disabling a second monitor. If you don't have a monitor connected, set this option to "Disabled" to improve the performance of the console. This option does nothing on Titan Mobile.

12.4 DMX output mapping

There are various ways to connect fixtures to the console. As well as the 4 XLR sockets on the console, you can connect fixtures using Ethernet and wireless links.

12.4.1 Configuring DMX outputs

Switch the console to System mode and select [DMX Settings] on the second page of options. The screen shows a list of available DMX *nodes* (places where you can send the DMX to) on the left, and a list of the 12 available DMX *lines* (outputs generated by the console) on the right. Each DMX line can send data to one or more nodes. If you assign more than one node to a line, those nodes receive duplicated data.

On the right hand side, under each DMX Line there is a list of which nodes are linked to that line. The default setting is for DMX Lines 1-4 to be linked to DMX Nodes Output A-D, the four XLR sockets on the console.

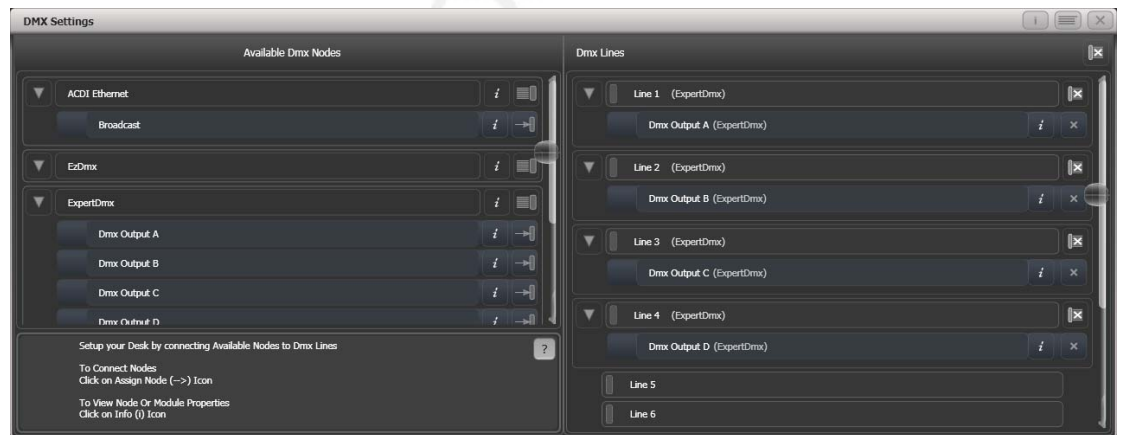

You can individually assign Nodes to Lines using the arrow button, or assign all Nodes of the same type using the group assign button. For example, to assign the four XLR output sockets on the back of the console to four DMX lines, you would click on the Group Assign button of the ExpertDMX nodes.



To assign a node to a line, click on the arrow on the node (the node will be highlighted), then click the line you want to assign to it.

To delete a node from the DMX lines, click on the X button. To delete all nodes from a line, click on the Group delete button

You can show information about the DMX nodes, or the DMX lines, by clicking the i button. For Ethernet/network type nodes, this allows you to set detailed properties such as IP address ranges and net masks.

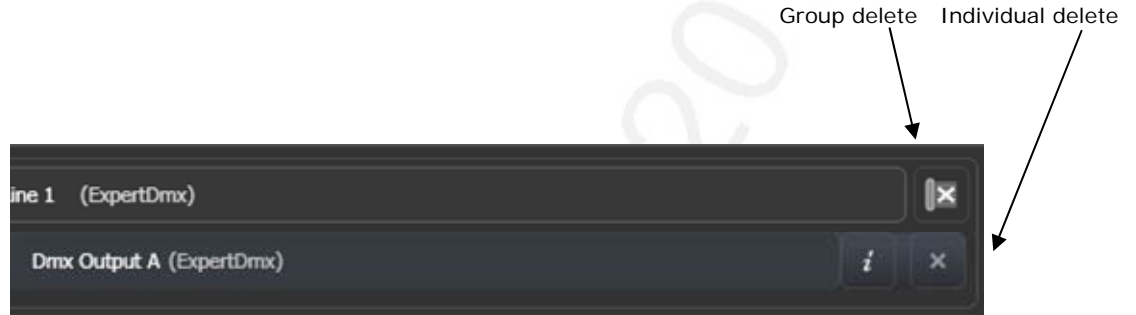

12.5 Curves

The console provides a variety of curves which set how the console tracks the fade; either the same speed all the way (linear), or starting and ending gently but faster in the middle, and various other options.

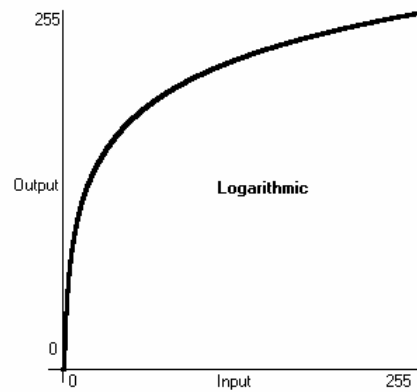
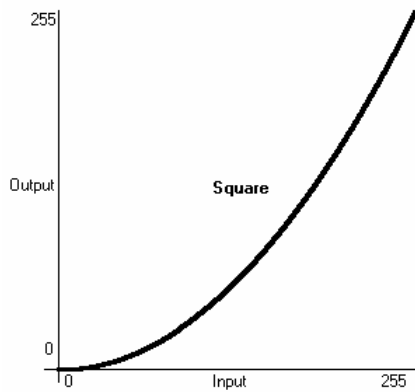
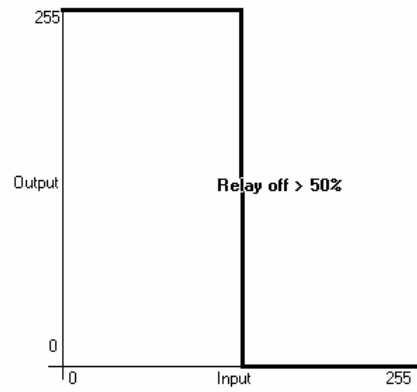
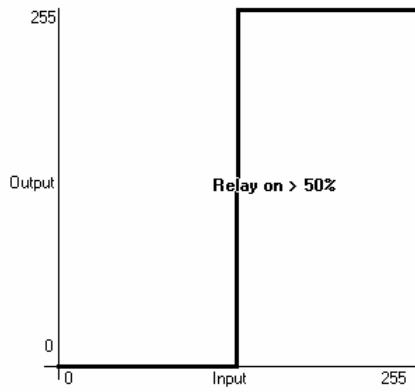
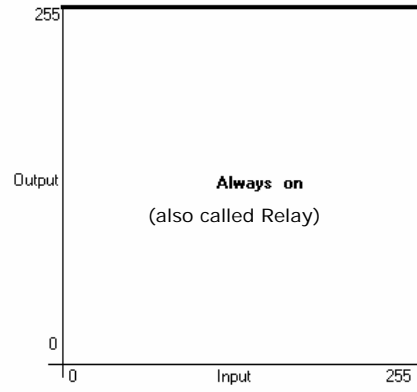
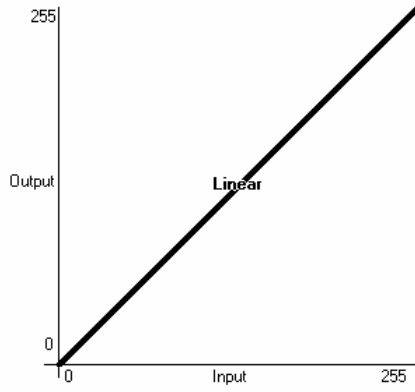

Copyr.

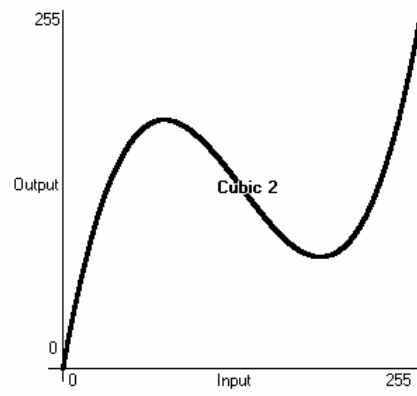
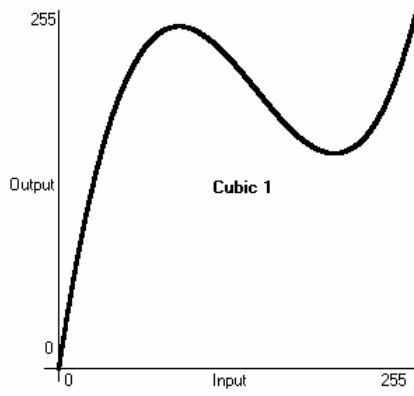
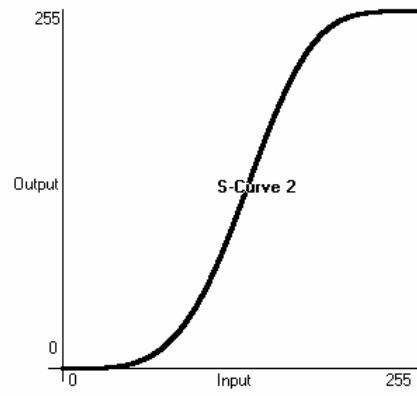
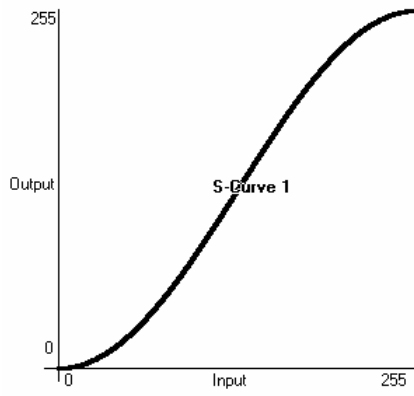
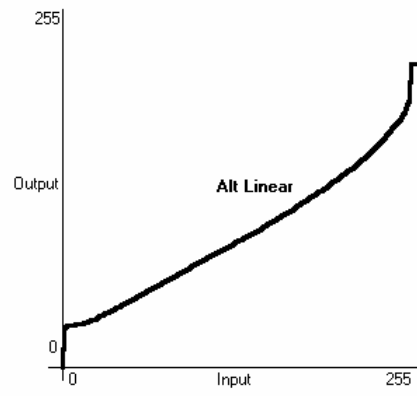
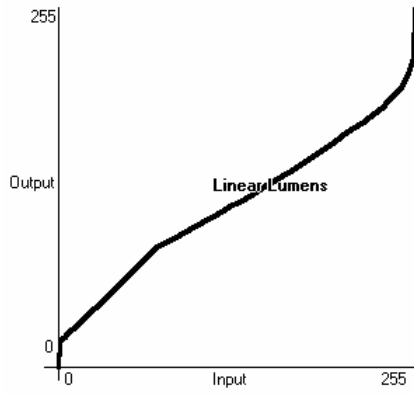

Copy

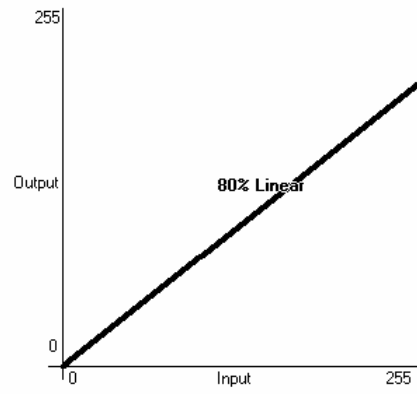
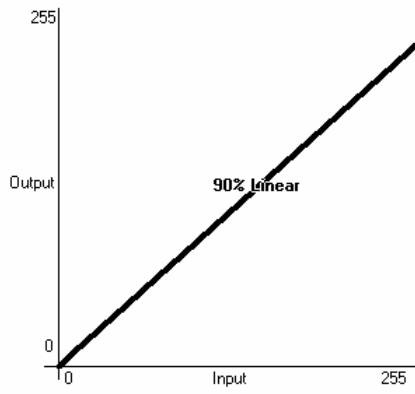
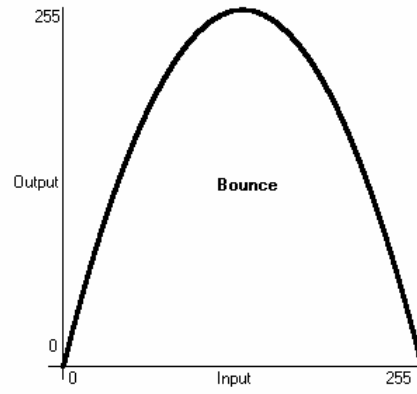
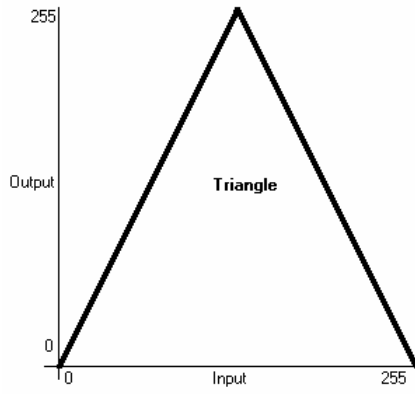

Copyright AVUTE

12.6 Upgrading the software

The console operating software is under constant revision by the Avolites team. You can always download the latest version of the software from the Avolites website:

<http://www.avolitesdownload.com>.

The Titan Mobile software is installed simply by running the installer program. Please ensure you have exited the Titan Mobile software before running the installer.

Copyright Avolites 2011

Copyright Avolites 2011

13. Working with Fixture Personalities

For each type of fixture, the console has a “personality” file which tells it how to control the fixture, which channel is the dimmer (HTP) channel, and a large amount of other fixture-specific information. When you patch each fixture, you tell the console which personality to use for it.

The console holds a personality library containing all commonly used fixtures, but you might find a fixture it doesn't know about. This section explains what you do when this happens.

13.1.1 Downloading fixture personalities from Avolites

The Avolites website lists all fixtures for which personalities have been created. You should look here first if the console does not contain a personality for your fixture. The address is

<http://www.avolitesdownload.com/personalities/>

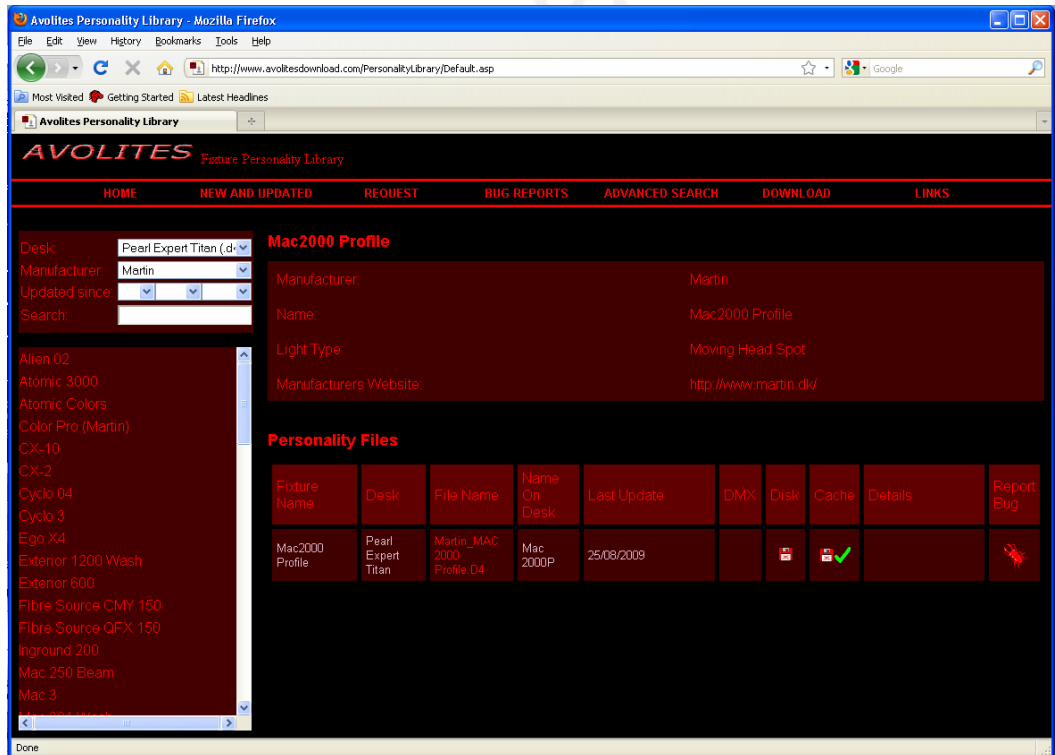

All available fixture personalities are listed down the left side of the screen. You can use the boxes on the top left to filter the list to show fixtures from specific manufacturers, or fixtures available for a certain console, or to search for a specific fixture name.



Ensure you have selected the correct console type in the “Desk” field. All Titan consoles use the same personalities, but the installer program is customised to the different consoles.

Click on the fixture name to open the details in the right hand window. This shows all the personalities available for that fixture

type (if you have entered the console type on the top left, only personalities for that console will be displayed).

If the personality is included in the standard library (cache) then the column will be ticked.

If there is a personality listed for your fixture, download it by clicking on the Disk icon. This will download a copy of the complete personality library.

13.1.2 Updating the personality library on the console

Download the current Titan personality library by clicking on the disk icon in the Cache column for any fixture. Alternatively you can get this file by clicking on the Download link at the top of the screen, then clicking on the link for your console.

Then use the following procedure.

Tools

1 > Locate the downloaded file TitanMobileFixtureLibrary.exe and double click on it to run it. Click

- The console caches the FixtureLibrary folder into memory when the Patch option is first used. You therefore need to restart the console to ensure new fixture personalities are loaded (restarting the console application is sufficient).
- Once a fixture is patched, its personality is embedded in the show file. Any changes to the fixture library will not affect fixtures patched in the show.

13.1.3 Requesting a new fixture personality

If a personality does not exist for your fixture, Avolites will create one for you. Click on the "Request" link on the above web page to submit your request. A list of current requests is shown, so you can check if someone else is asking for the same thing.

Your new personality will be incorporated into the library – to install the new personality, download and install the latest personality library as described above.

13.1.4 Reporting a personality bug to Avolites

If you find a problem with a fixture personality, Avolites would like to know about it so it can be fixed. Search for the personality on the website then click on the "Report Bug" icon on the right of the screen. If you click on the "Bug Reports" tab at the top of the window, a list is shown of currently outstanding problems, so you can check if someone else has already reported the problem.

13.1.5 In an emergency

The console contains a selection of "Generic" fixtures which you can use in an emergency if you need to operate a fixture with no personality. When patching, go through the manufacturer list until you find [Generic]. In this section (among other fixtures) are the following:

Multi-DMX: Has up to 10 DMX channels, all channels are LTP. You can select from 1-10 channels on the Mode screen. Press Attribute Bank and use the softkeys to select channels.

Generic RGB: Allows you to control an RGB fixture such as LED colour changers. This offers 5 modes:

1=Dim 2=R 3=G 4=B

VDim 1=R 2=G 3=B

1=R 2=G 3=B 4=Dim

VDim + 4xRGB

4xRGB.

VDim is a virtual overall dimmer channel for fixtures without a DMX dimmer control. When you use the Dimmer attribute the console will adjust the RGB levels accordingly.

Copyright Avolites 2011

14. Networking the console

There are a number of ways for the console to communicate with lighting fixtures beyond the traditional DMX sockets, and these are described in this chapter. The console also supports communicating with a number of different simulators/visualisers over various communication methods.

At the end of the chapter is a section which aims to cover the basics of IP addressing, which is essential for various features on the console such as ArtNet.



Lighting networks need to transfer of large amounts of data. For best reliability you should use network wiring which is dedicated to the lighting system and physically isolated from other networks. Connecting to an existing network with other network traffic is possible but can lead to problems both with the lighting equipment and with other IT equipment on the network. If you need to do this please read about the IP addresses you should use, in section 14.5.5.

14.1 Controlling fixtures over a network

Before the console can talk to another device over the network, it has to be given a unique network address. This is called its "IP address".

14.1.1 Setting IP address

We recommend that you use the console's automatic IP setting function. However, if you need to you can also set the IP address using Windows Control Panel as shown on page 179.

```

1> Switch to System mode and press [Network Settings]
2> Press [Local Area Connection].
3> Press [Subnet Mask] and set to 255.255.255.0
4> Press [Set IP 2.*.*.*]
5> Press [Save settings]
6> Turn the switch back to Program.

```

- Some equipment may operate on IP addresses 10.*.*.* (softkey D) – see later in this chapter for details.
- If you need a non-standard IP address range you can use softkey A.

14.1.2 Setting up DMX outputs

The console has 12 DMX output lines which may be routed to physical DMX sockets or to network nodes.

Section 12.4.1 on page 162 tells you how to set up this routing, and an example is given in section 14.1.4 on the next page.

14.1.3 A simple ArtNet system

There are various different systems for sending lighting control information over a network. One of the most widely supported is ArtNet.

ArtNet is not specific to one range of products, and is recognised and implemented by a growing number of manufacturers. Many products (such as Dimmers and Moving lights) can accept the ArtNet signal directly, so there is no need to convert the signal to DMX. Most people will, however, need to output DMX to their equipment and this can be done using an ArtNet to DMX converter.

In the following diagram, an ArtNet compliant Console (such as a Titan console) is connected via a network hub to an ArtNet compatible dimmer and 2 DMX conversion boxes.

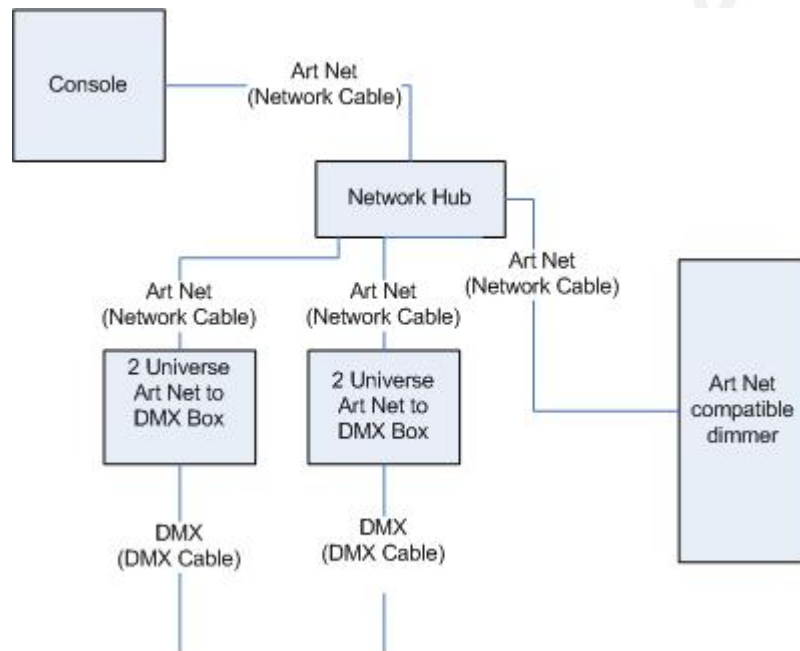

Once the system is connected together, the different outputs (or Nodes) can be configured.

- The dimmer is given the start address of 200
- The 1st DMX box is set to universe 1 and universe 2
- The 2nd DMX box is also set to universe 1 and universe 2

The console is then used to set the DMX lines to the Art Net nodes.

It is important to remember:

- Each Art Net to DMX box (or compatible Dimmer, or compatible moving light) is a device,
- Each device may have one or more nodes (i.e. the Art Net to DMX box has 2 nodes, these are the 2 DMX outputs; the dimmer itself is a node),
- Each node can be set to a Universe (1-256). This universe is equivalent to a 512 channel DMX line

You can then specify which console line is assigned to each node. A console line can be assigned to multiple nodes (this will duplicate the DMX universe), but each node should have only one console line assigned to it.

Here, the console assigns the following:

- Line A to Box 1 universe 1 and box 2 universe 1
- Line B to Box 1 universe 2
- Line C to Box 2 universe 2 and the dimmer rack

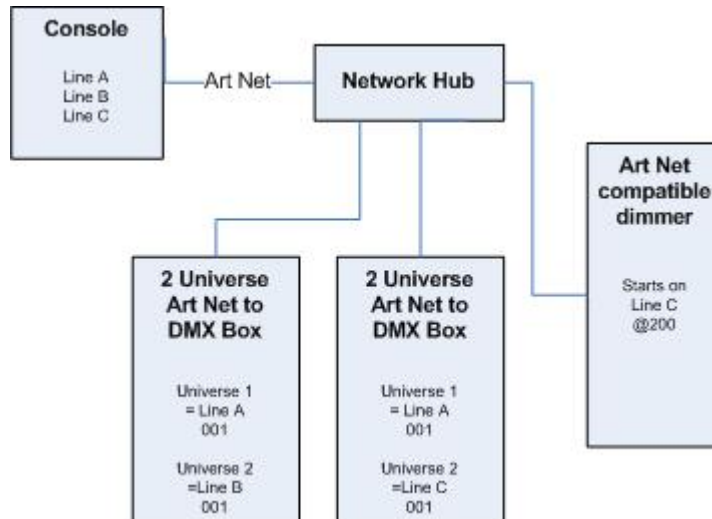

14.1.4 Setting up an ArtNet system

For this example, it is assumed that you will connect the console to an Art Net DMX output box (such as an Artistic License Net-Lynx) via a network hub.

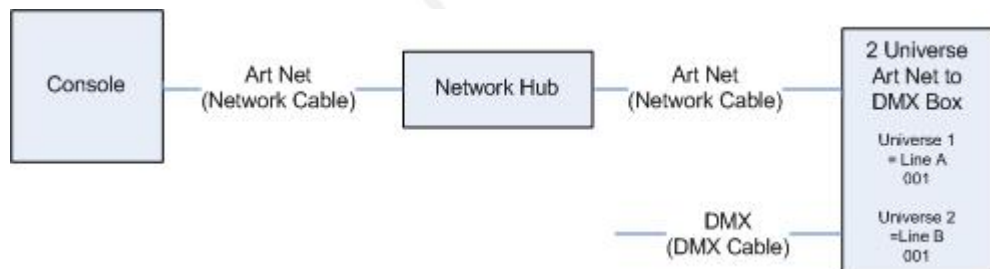

Using standard network cables, attach the devices together.

- If you are using a hub/switch as shown above, use straight-through cables. If you are directly connecting the console to another Ethernet device you need to use crossover cables

Set the Net-Lynx box as follows:

- Subnet Mask = 0
- DMX A Universe = 1
- DMX B Universe = 2

A lot of ArtNet devices, including the Net-Lynx box, are set to IP address 2.x.x.x as default, and can be set to 10.x.x.x using an option jumper, so you should check what the setting of your device is.

If your ArtNet devices need to be set to a non-standard IP address, then in steps 1 and 2 you need to use Windows Control Panel to set the console to that address range instead of 2.x.x.x

With everything connected, start the console.

-
- 1> *Ensure the console has an IP in the 2.x.x.x range as described at the start of the chapter.*
 - 2> *Switch the console to System and select [DMX Settings].*
 - 3> *The DMX Settings window should open.*
 - 4> *Select the ArtNet module from the node list in the left hand side of the window.*
 - 5> *Press the small 'i' button to show the node properties. Ensure that the correct Network adapter is set (this may not be the Default Adapter)*
 - 6> *If you wish to turn off the Art Net output, you can unselect the "Enable DMX output" option. This will stop the Console from outputting Art Net on any Lines.*
 - 7> *Art Net normally only sends Data when it is changed, rather than a continuous stream. There are times when it is preferable to send Art Net all the time. to do this, select the "Continuous ArtNet Data Stream" option.*
 - 8> *The "Always broadcast ArtNet" option enables you to send Art Net to the entire network, rather than a specific IP address.*
 - 9> *Press the blue → arrow on the ArtNet node to connect it to a DMX output line.*
 - 10> *Select a console DMX line from the right hand side of the window.*
 - 11> *The DMX line will now be outputting over the selected ArtNet node.*
 - 12> *Click 'i' on the node you have added to make sure the properties are correct. (Problems can be caused if you attach multiple DMX lines to a single node.)*
 - 13> *Make sure that the Universe is set to 1 for Line 1, and 2 for Line 2.*
Art-Net uses a subnet mask with its universe. For Titan purposes:
Titan universes 1 - 16 are subnet mask = 0, Art-Net universes = 1 – 16
 - 14> *You can close the DMX settings window.*
-

The console should now be working correctly.

To remove a node from a DMX line, select the node and click the blue X button.

14.1.5 Additional ArtNet Resources

To find out more information about Art Net please refer to the Art Net Standard published by Artistic Licence.

14.2 Connecting to a simulator with ACDI

ACDI is Avolites' Application for Interfacing Consoles and Simulators with lighting software such as Visualiser, Capture or Show designer.

14.2.1 ACDI

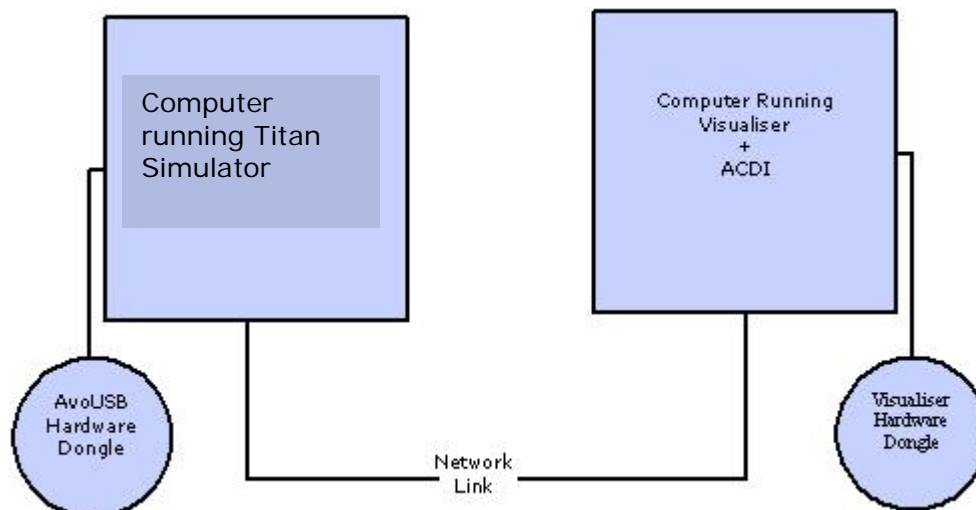

The network link connection can be made through either a crossover cable, or through a network hub.

For this example, both computers are connected together via a crossover cable.

First, we will set up the Network setting for both computers. It is important that both computers use an IP address in the same range (2.0.0.x in this example) and have the same subnet mask, or they won't be able to communicate.

On the console, set the address to 2.x.x.x as described in section 14.1.1 at the start of this chapter. If you need to set a custom address to match the visualiser PC you can use Control Panel to do this.

On the computer running the Visualiser:

-
- 1> Click Start, Control panel, Network connections.
 - 2> Right click on the connection you wish to use.
 - 3> Click Properties.
 - 4> In the connection properties window select TCP/IP and click Properties
 - 5> Set the PC network adapter to a free address on the network in the range 2.0.0.x.
 - 6> Set the subnet mask to 255.0.0.0.
 - 7> Click OK.
-

Close any network windows on both machines.

Install and run ACDI on the Visualiser Computer.

In ACDI change "Source" to "Simulator"

Do not close the ACDI window

Refer to the previous section to setup a DMX line on the console to be sent to the Visualiser.

Finally, start the console, and open or create the theatre file. (See the Visualiser manual for more information on this)

Once ready to connect to the console, go to run mode in the Visualiser, and select simulator under DMX.

The console should now be working with the Visualiser.

14.3 Module Setup

A module is a method of sending DMX and can be thought of as a collection of nodes.

For example, consider using wireless networking technology to transmit DMX to several individual receivers. Each receiver is configured to output a specific universe of DMX. In this case, the wireless system as a whole is the module, and each receiver is a node.

You can set the specific properties of the Modules used with the console by going to the DMX Settings window (switch to System mode and select [DMX Settings]) and then click the small 'i' at the right hand side of the module name.

This allows you to adjust settings for each module, and to select a network adapter for ACDI and Art-Net. The consoles only have one network adapter, however on Titan Mobile and Simulator this depends on your computer; many laptop users will have their standard network adapter and also a Wi-Fi (wireless) adapter, both of which will be shown.

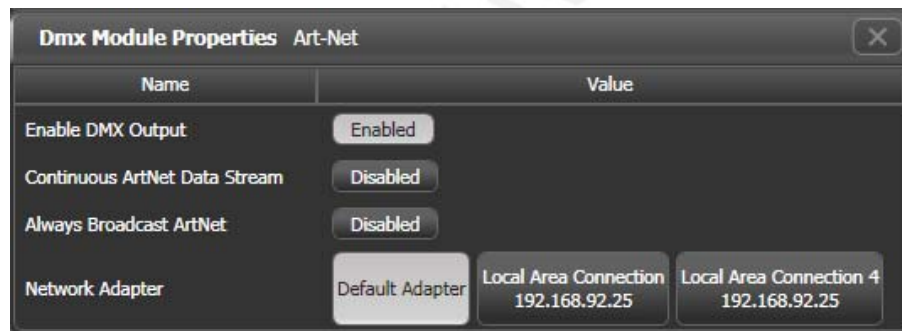

14.4 Using Active Fixtures with CITP

CITP is a standard system allowing lighting devices to communicate and share information. This is often used with media servers to allow the console to get media thumbnail images and layer information from the server. The thumbnail images can then be used on the console to select media clips.

14.4.1 Example CITP setup

This example shows how to set up a Hippotizer with Titan Mobile.

- 1> *Connect the console and Hippotizer to the network. (You can connect the Hippotizer directly to the console, if no other devices are being connected, using a crossover patch cable).*
- 2> *Set up the IP addresses and subnet masks of the console and Hippo so that they are on the same address range, for example 192.168.0.1 and 192.168.0.2.*
- 3> *If you are using Titan Mobile or Titan Simulator ensure the firewall on your PC is disabled. Also ensure the Hippo machine is not running a firewall.*

- 4> *Run the Hippo system. Make sure the CITP component is running.*
- 5> *Switch the console to System mode and select [DMX Settings].*
- 6> *On the left hand side under Art-Net you should see the Hippo with its IP address. Click on it and then on the right hand side click on the DMX line you want to use it with.*
- 7> *On the Hippo node on the left hand side, click the 'i' button and set the Universe number to match the universe setting on the Hippo.*
- 8> *Exit System mode back to the default menu.*
- 9> *Close and restart the Titan software.*
- 10> *Go into Patch mode and select [Active Fixtures]. You should see the Hippo with its IP address as a softkey option.*
- 11> *Select the Hippo, then set the DMX line to match the line you set in Step 6.*
- 12> *Press an empty fixture handle to patch. The console will automatically patch the required layers and master layer as a series of fixture buttons.*
- 13> *Now if you select a fixture and open the Attribute Editor window you should see the media thumbnails.*

The next time you start the system, ensure the Hippo is powered up before you start the console.

If you decide to re-patch to a different DMX address you will need to re-start the Hippotizer software. You will also need to reset the ArtNet nodes if you are moving across DMX lines.

14.5 All about IP addressing

This section attempts to explain the basics of IP addressing, and what you will need to know when setting up a lighting control network.

IP addresses will normally come in the format "w.x.y.z" where w, x, y and z are numbers between 0 and 255. For example "298.23.46.166". Every object (or node or device) on a network should have a unique IP address. This is the same concept as DMX as each fixture requires a unique DMX address, for IP addresses the same is required.

14.5.1 Setting your IP address

The console has a setup function to quickly set its IP address as described on page 173

You can also set your IP address in the same you would on a Windows XP computer. This is done in the following way:

-
- 1> *Go to the control panel from the Tools menu*
 - 2> *Double Click on Network Connections*
 - 3> *You will now be confronted with various network adaptors. It is likely that you will only have one or two of importance. The "Local Area Connection" and "Wireless Network Connection". These names may slightly differ but the icons are likely to look like these:*



- 4> *The Local Area Connection (icon on the left) refers to your wired connection and your Wireless Network connection (icon on the right shown disconnected) refers to your wireless connection.*
- 5> *At this point you need to decide which connection you are using and therefore which connection you want to set the IP address for. Select this connection, right click on it and click on Properties.*
- 6> *The Dialogue box you have should have at least three tabs, "General", "Authentication" and "Advanced". It should already be on the General tab which is the only tab where you should need to change settings.*
- 7> *In the middle of the box there is a selection box labelled "This connection uses the following items:" You need to select the item called "Internet Protocol (TCP/IP)" ensure this is ticked and click on "Properties" just below the selection box.*
- 8> *You are now presented with a box which allows you to select whether you want to "Obtain an IP address automatically" or "Use the following IP address". By selecting "Use the following IP address" it is possible to enter in a new IP address and Subnet Mask. The Default gateway, Preferred DNS server and Alternate DNS server and not important in this situation as they are only required if you are connecting to the internet, therefore they can be left blank.*
- 9> *Once you have entered in the new IP address and Subnet mask press Ok on all the dialogue boxes that have been opened. After a few moments your new IP address should be set.*

There is a strong possibility that if you set the IP address on one network device you will have to set it on all of them, therefore if you manually set your IP address on the console you will have to do it on any tracking backup you are using and any ArtNet fixtures. Beware that some ArtNet fixtures have a fixed IP address in the range 2.x.x.x, in which case you have to set the console to that range.

14.5.2 Subnet Masks

These are best kept simple. All devices or nodes on a network who wish to communicate with each other must have the same subnet mask. The mask determines which parts of the IP address are unique in that network to each node. If the part of the subnet mask is a 0 then the corresponding digit in an IP address must be unique for each fixture. If the part in a subnet mask is 255 then this part of the IP address needs to be the same for each node.

14.5.3 Choosing an IP address and Subnet Mask

This is the hardest part of setting up a network as your IP address totally depends on what you are using on the network and what IP addresses you can and cannot change. Below are a number of different scenarios for standard lighting networks using a Titan console and what IP addresses should be set. These aren't

guaranteed to work but try them if the scenario matches your network:

Titan and ShowSafe, all output is standard DMX.

	IP Address	Subnet Mask
Titan console	192.168.1.30	255.255.255.0
ShowSafe	192.168.1.31	255.255.255.0

Titan outputting over ArtNet Fixtures (and DMX).

	IP Address	Subnet Mask
Titan console	2.100.100.100	255.0.0.0
ArtNet Fixtures	2.x.y.z	255.0.0.0

Or

	IP Address	Subnet Mask
Titan console	10.100.100.100	255.0.0.0
ArtNet Fixtures	10.x.y.z	255.0.0.0

Where a combination of x, y and z are unique for these fixtures.

Titan and ShowSafe outputting over ArtNet (and DMX).

	IP Address	Subnet Mask
Titan console	2.100.100.100	255.0.0.0
ShowSafe	2.100.100.101	255.0.0.0
ArtNet Fixtures	2.x.y.z	255.0.0.0

Or

	IP Address	Subnet Mask
Titan console	10.100.100.100	255.0.0.0
ShowSafe	10.100.100.101	255.0.0.0
ArtNet Fixtures	10.x.y.z	255.0.0.0

Where a combination of x, y and z are unique for these fixtures.



Never set the last number of an IP address to be 255. This is a special address which will not function correctly.

14.5.4 Automatically assigning IP addresses (DHCP)

There is another way of assigning IP addresses via an automatic system called DHCP. For this you need one of the devices on the network to be a DHCP server. If you know none of your devices are a DHCP server then this is irrelevant however, if you have a router on the network or some such similar device then it is likely that you have a DHCP server. If you do then in the 8 step instructions in section 14.5.1 on page 179 when you come to step 7 you should ensure that "Obtain an IP address automatically" is selected then press ok. When you are using DHCP all the devices on the network must be capable of obtaining an IP address automatically. If one

device cannot (eg some ArtNet devices) then you must manually set all the IP addresses.

14.5.5 Private IP address ranges

If your network is connected to the internet it is important to use a private IP address range. These are special IP addresses that will not be routed onto the internet. They are:

Start Address	Final Address	Subnet Mask
10.0.0.0	10.255.255.255	255.0.0.0
172.16.0.0	172.31.255.255	255.255.0.0
192.168.0.0	192.168.255.255	255.255.255.0

For Art-Net, the 10.x.x.x range must be used.

14.6 Repairing a Network Connection

If you are sure your network connection settings are correct or had them working but they are no longer working it may be necessary to repair the network connection. This is a simple windows function that can be accessed by doing the following:

-
- 1> *Go to the control panel from the Tools menu.*
 - 2> *Double Click on Network Connections*
 - 3> *Double Click on the Network Connection you would like to repair*
 - 4> *Click on the Support tab.*
 - 5> *Click Repair.*
-

Windows will complete a number of tasks and give you a message informing you it has finished repairing the connection. Click close then ok to all the open windows.

15. Using different Avolites consoles

If you are used to other Avolites consoles, this section will help you to cope with the differences between each console.



Shows from a Titan console can be loaded into any other Titan console, but not into the Pearl Expert running Classic software, or a Diamond 4 running Classic software, or a Pearl 2000/2004/2008 console, because these consoles have a different show file format.

15.1 The console controls

Titan Mobile is very similar in operation to the full consoles, but some controls are in different positions.

The 'attribute bank' buttons are immediately below the wheels rather than down the right hand side, and are labelled using IPCGBES functions rather than the usual attribute names.

The command buttons are to the right of that. There is now only one Record button which can be used for recording any type of playback.

Titan Mobile only uses one monitor, so any workspaces on a second monitor will not be visible.

Using Pearl Expert shows

If you are using a show from a Pearl Expert, anything programmed on the preset faders won't be visible as Titan Mobile doesn't have any preset faders. However, by using the Compatibility View on the touch screen (press View, [Open Workspace Window], [Fixtures and Playbacks] or [Groups and Palettes]) you can access fixtures, playbacks, groups and palettes from the preset faders. If you wish you can copy items to a normal workspace window using the [Copy to Workspace] context button.

Cues and Chases on the touch screen

In addition to the playback faders, you can store cues (memories) and chases on the touch screen using the Playbacks window. For playbacks which don't need a fader, this gives you instant fingertip access to an enormous number of effects.

Macro buttons

20 buttons are provided in which you can store frequently used button sequences. Any sequence of button presses can be stored in each of these buttons making those repetitive programming tasks a thing of the past. If you need more than 20, you can show a Macro window on the touch screen. The 20 console buttons are the same as the first 20 Macro touch buttons.

Change button functions

You can change the functions of the blue and grey buttons on the console to give you quick access to the functions you want, such as Preload, Stop and Go for chases, Tap Tempo and so on. This feature is called Key Profiles (see page 161).

Titan Remote

Titan remote runs on a mobile device's web browser and can control the console using Wi-Fi. This is invaluable for focusing, and you can also activate playbacks.

15.2 Programming features in Titan

There are some great programming features in Titan consoles which previously were only found on the Diamond 4.

Fixture overlap, Attribute overlap

The overlap functions allow you to sequence the way a cue plays back. Normally when you fire a cue, everything would move to its programmed setting all together. The fixture overlap feature causes each fixture to move to the new setting in sequence, giving some amazing roll or peel effects without any programming. Attribute overlap is a similar effect with different attributes. When "busking", palettes can also be applied with overlap.

Fixture exchange and Copy Fixture

The Fixture exchange function enables you to replace fixtures which are used in your show with alternative fixtures, retaining important elements such as cue times, shapes and legends. It is very useful for touring shows and venues with a high turnover of events, allowing you to cope with different house rigs or equipment availability.

You can copy fixtures you already have in your show. The new copy will come complete with all the cues and palettes of the original fixture you've copied.

Multiple times

The Titan software allows multiple timers for cues. This means in a complicated show you can have lots of fades going on from different cues each under the control of a different timer.

Playback priorities

You can configure how playbacks will behave if you turn on two playbacks controlling the same fixture. For each playback, priority can be set to Low, Normal, High or Very High. If a fixture is being controlled by a playback and you turn on a playback of the same or higher priority, then the new playback will take over. However, if the new playback is set to lower priority than the first playback, the fixture will not change.

This is useful if, for example, you've programmed looks using all your fixtures, then you decide you want a couple of them to spotlight a singer. If you set the Spotlight playback to be high priority, then while it is active no other playback will affect the spotlight fixtures.

Undo/Redo

Undo/Redo buttons allow you to undo an action if you do something and later regret it.

Release

When a playback is killed, you can set how the LTP channels release. The default setting is to not release any attributes (i.e. LTP channels will not change when the playback is killed), but you can set attributes to revert to their state in the most recently active playback.

Copyright Avolites 2011

Copyright Avolites 2011

16. Release notes

This section describes changes in the most recent version of software. Please ensure you save and backup your shows before attempting to upgrade any software.



This section only lists the changes in the most recent update; for changes in earlier versions, please check the release notes provided on the console using the VDU menu option Help → Release Notes.

16.1 Version 5.0

16.1.1 Upgrading from: 3.1:

There is no upgrade path from versions prior to 4.0 and so the software must be installed by running a recovery disk. You can download a recovery disk containing this software from Avolites download. Please follow the instructions given when downloading the recovery disk to install this version.

16.1.2 Upgrading from: 4.0:

Please ensure you save and backup your shows before attempting to upgrade any software. An automated upgrade path from Titan 4.1 is provided. Upgrading from any other version requires the running of a Titan 5.0 recovery disk. You can download the latest Titan software from Avolites download. Full instructions for upgrading both with an installer and a recovery disc are supplied with the download and can be found in the console manual. The installer upgrade procedure is reproduced briefly below.

Please save the software to a USB stick or other media and follow these instructions.

Shutdown the software by selecting 'Shutdown Software' from the tools menu. Insert the USB stick in the console and click on the yellow 'Folders' icon on the tools menu of the console. Find the setup file you saved to the USB stick double click to run it. Follow the instructions presented by the installer, taking care to read each step carefully. Once the setup completes you need to restart the console. When the console restarts it should be updated to the new software, please check this by reading the version number in system mode.

16.1.3 New features in v.5.0

Quick Build: The quick build feature allows you to easily build cues, chases and cue lists from existing cues and palettes. By simply selecting a range of colour palettes you can create a colour chase. To use quick build start recording a chase and then from the

record mode select [Quick Build]. You can select any palette or playback insert that item as a new step in the chase. To filter by specific fixtures just select the fixtures first and then select the palette or playback. If you range select over the palettes then each palette will be added as a separate step. You can also use quick build when recording a single cue to merge multiple palettes/playbacks into the same cue.

Fixture Order in Groups: Groups can now have a fixture order so that when you apply that group the order is entered into the programmer. This has several advantages, the first being that the order is also recorded into the cue meaning that complex orders do not have to be setup individually in each cue. The other benefit is that the order is used when apply palettes with an overlap. To change the order within a group, select [Group] [Edit Groups] followed by the group you want to edit [Edit Layout] . There are two ways you can arrange the order, either with the layout editor which is described in the "Fixture Layout in Groups" feature or using the standard fixture order editor. If you now press [Fixture Order] you can change the order by selecting the handles of the fixtures.

Fixture Layout in Groups: Groups now contain a location in 2D space for fixtures recorded in the group. This information is used when running pixel mapper effects. Each fixture has an X and Y location where X is the old fixture order. To edit the locations of the fixtures select [Group] [Edit Groups] [Edit Layout] and then select the group to edit. This will open the layout grid which you can drag the fixtures around on. Some auto layout options are available. The grid size can be changed by dragging the bottom right corner of the grid.

Fade between Channel Ranges: In previous versions if you went between two distinct ranges of a fixture attribute it would snap the channels. The software now tries to fade the channels if it can. This result is smooth transitions for controls such as Gobo Spin and Shutter.

MIDI or DMX Triggering: You can now trigger many features of the console from external triggers. MIDI and DMX triggering is available. This powerful feature is explained much more fully in the Version 5 Titan manual. Briefly, to set up triggering connect your external device then enter System mode and select the Triggers menu. Add a new Trigger mapping and give it a name. Add a trigger to the mapping then select what you wish to trigger. To trigger a fader or button on the console press it or move it. To trigger a specific playback, fixture, palette, group or macro toggle to Trigger Type [Item] and select the item to trigger. Now scroll through the list of available actions. Having selected an action or piece of hardware select [Ok]. Now choose MIDI or DMX triggering and, if using DMX triggering, select the DMX port. Then either enter the MIDI or DMX address to use as a stimulus or simply generate the stimulus from your device, the console will learn the trigger and fill in the details for you. Now Add the trigger. Repeat to add as many triggers as you wish.

Sub Fixtures: Using sub fixtures allows you to group cells of a fixture in one super fixture. This negates having to patch multi celled fixtures as many separate fixtures. When you patch a fixture which has sub fixtures it will appear as a single fixture and have one DMX address. You can then drill down into that fixture by selecting

[Unfold] then the handle of the super fixture. This will give you individual control of the cells of the fixture. In order for sub fixtures to work the personality must include this feature and it may take us a while to update old personalities. Where sub fixtures really come into their own is when laying out fixtures for pixel mapping. Any fixture which contains sub fixtures can be moved and rotated as a single fixture but the individual cells are still mapped separately.

FX Added to Attribute Mask: The attribute mask has a new bank called FX on top of IPCGBES. The extra bank incorporates shapes and pixel map effects allowing for these items to be masked when recording and updating your show.

Shapes in Palettes: You can now save shapes and shape parameters into your palettes for easy programming or quick live operation. A palette may now store any combination of shape and shape parameters such as speed and size. To store a shape in a palette, set the shape up in the programmer and store the palette. The pattern of the shape is masked by the FX bank in the attribute mask so take care that this is enabled when recording the palette. The Parameters like size and speed obey the individual fixture attributes so Position will mask any parameters for a Pan/Tilt shape. A shape workspace window is available to help you organise any shape palettes.

Run Macro from Cue: You can now fire macros from a cue within a cue list. This allows you to setup custom actions which are then performed when a cue in a cue list fires. You may want to lamp on your fixtures when the first cue fires in the cue list and this can all be done by linking the macros to the cue.

View Palette: You can now view the contents of a palette and adjust the attribute values. To view a palette, select View and then the palette you wish to view. A new window will open which lists all the fixtures in the palette as well as their attribute values. You are shown both the shared and normal palette information. The values can be directly edited just by selecting the cells containing the values and entering the new level.

Select If: Using Select If allows you to select fixtures based on whether they are controlled by a particular palette or playback. Pressing [Select If] followed by a palette it will select any fixtures that are using that palette (even if not in the programmer). To select fixtures in a playback you press [Select If] and then select the playback. Finally you can select fixtures at particular levels by combining [Select If] and the [@] key. A full description of select if functions can be found in the manual. On the Tiger Touch and Pearl Expert consoles you will find [Select If] in the channel menu.

Flash Full and Flash Out: The Flash Full function will temporarily flash all selected fixtures to full intensity while the key is held. The Flash Out function performs the opposite by setting them to zero intensity. This feature is only available on consoles with [Flash Full] and [Flash Out] keys.

Remainder Dim: Takes all the fixtures that are not selected and sets their intensity to zero. The zero intensity is placed in the programmer and will be recorded into any cue. So to zero the intensity of every fixture except the few that you are working with, first select the fixtures you do not want zeroed and then press [Rem Dim]. This feature is only available on the mobile.

Lock Desk: You can now lock the console with a security code to prevent layabouts fiddling with your show. When the console is locked all functions of the console are disabled except the DMX outputs and currently running playbacks. To unlock, enter the password you used to lock the console or restart the console. To lock the console press [Shift] + [Lock] and then enter a password followed by [Enter].

Patch Quantity of Fixtures: When patching fixtures you can now set the quantity of fixtures to patch. This simplifies the process of patching large numbers of fixtures. You now just set the quantity you want to patch and then select the first handle where you want to patch the fixture.

Edit Personality: Sometimes you may find that the personality of a fixture contains errors and needs minor changes. With edit personality it is now even easier to correct these errors. Go to [Patch] and then select [Edit Fixtures] followed by [Edit Personality]. You will now be presented with a list of all fixture types currently patched in the show. Select the fixture you want to edit the personality for. This will open personality builder which allows you to make the required changes. When you save the changes your show will automatically be updated.

Pixel Mapper: The pixel mapper allows the creation of 2D shapes which control the colour or intensity of groups of fixtures. To use the pixel mapper first create a group of the fixtures and lay them out in the group using the group layout tool. Then select the group and from the root menu select [Shapes and Effects], [Pixel Mapper], [Create Effect]. The effect editor window will open with a blank black background. The effect is made up of elements and animations, to add an element press the [+] button and select an element such as a Block. A white block will appear in the middle of the effect editor preview pane. Fixtures which are laid out in the middle part of the group will change to white. If you are using RGB or CMY fixtures and don't see any output ensure the dimmer channel is at full. The element is now selected and you can move it around and change its properties using the sliders of the property pane. With the element selected you can add an animation by pressing the [+] button again and selecting an animation such as a movement. The block will then start to move and as it moves the relevant fixtures will change colour according to their positions. Once you have an effect you like you can record it to a playback and clear the programmer. Raising the fader on the playback will fade in the effect.

Pixel Mapper Preview Window: The pixel mapper preview window shows the output of the effect engine and pixel mapper before it is applied to the fixtures. Open the window from the [Open Workspace Window] menu. The bottom part of the window shows buttons for all running effects with thumbnails. The top part of the window shows a larger view of the most recently fired or selected effect. Note that for efficiency the preview window updates at a slightly slower rate than the real output.

Auto Groups:

When patching multiple fixtures it now automatically creates a group for you in the group window. You will notice two types of auto groups being created. The first is a fixture type group which will always contain all fixtures of the same type. The second is a group which is created when you either range patch or specify a quantity. A new

group is created for each batch of fixtures you patch. This feature can be turned off in the user settings.

Master Palette Overlap: In the same way as you can set a master palette time you can now set a master palette overlap. This overlap will be used when no other overlap is found. The option is accessed through the palette menu by pressing the [Palette] key.

Update: The update function allows you to update the attribute values stored in a fired playback with the corresponding values currently in the programmer. The update function can be found under the Record Cue menu, or on the Titan Mobile, there is a dedicated button. By default the palettes referenced in all active playbacks or, if no palette is used, the playbacks themselves will be updated. When initially entering the function the palettes and playbacks which will be affected are highlighted and listed in the softkeys. Pressing Enter or the Update button will confirm the current selection, alternatively individual palettes or playbacks can be selected by pressing the swop button twice.

16.1.4 Improvements in v.5.0

Exchange fixture maintains fixture legend: When a fixture is exchanged it now maintains any user set legend rather than reverting to the exchange fixture name. If no legend has been set it will be renamed to the exchange fixture name.

Updating of playbacks with palette links: In previous versions of the software, where a playback linked to a palette, if the original palette was updated only channels programmed in the playback would be updated from the palette. This has been changed so that playbacks may add channels from a linked palette (being updated) if the channel is not already being controlled in the playback. This means that adding new channels into a palette will cause the playbacks to update with this new information. The greatest benefit to this is when exchanging fixtures.

Fixture Exchange Mapping Hints: The console now contains a fixture exchange hints file which helps the software to decide which controls map to which. This ensures that any awkward fixtures to exchange can be dealt with by adding exceptions to this hints file. The file is maintained by Avolites and distributed with the Fixture Library. This should ensure that exchange works well every time.

Fading of shape phase is now smoother: Fading the phase of a shape between two phase offsets is now a lot smoother than in previous versions.

Stop on Final Cue works with bounce and Random: The stop on final cue setting now works with chases set to bounce or random mode. The chase stops when all the cues have been played.

Unassigned DMX ports stop sending DMX: When a physical DMX port is unassigned it now stops sending DMX data.

Frozen Attributes Saved in Show: Frozen fixture attributes are now frozen so their state is restored when the show is reloaded.

Mask in Quick Include: You can now set a mask in quick include. This avoids having to go into advanced include just to set a mask.

You can now press [Include] followed by an attribute bank button and then the handle to include.

1 THROUGH 10 [Highlight]: The command syntax 1 THROUGH 10 [Highlight] now works.

Dongle License through Panel: The dongle license code can now be entered through the panel software and a clearer warning is given when the dongle is removed. This makes it easier to license the console after a recovery.

Fan Options menu Curve Type: The fan options menu now shows the selected fan curve.

Window Page in Workspace Shortcut: The current workspace window page is now recorded in the workspace shortcut. This ensures the view is restored correctly.

16.1.5 Bugs fixed in v.5.0

The Titan engine may crash with chases of excessive dimmers:

Running a chase containing in excess of 1000 dimmers with the channel grid open might have caused the software to crash.

Copying a fixture did not copy Invert and Swop PT: When copying a fixture the inverted attributes and the swop Pan and Tilt settings would not be copied. Instead they would revert to the default values.

Intensity quick palettes re-apply from Cue List: When running an intensity quick palette with any chase or cue list the palettes may reapply when the cue list or chase wraps around to step 1.

Fixture overlap in Mode 3 cus does not work correctly: Using fixture overlap in a Mode 3 cue would not work correctly with the LTP channels not going to the desired values.

Include Fade In: If you included channels from a cue with fade times on the attributes then the channels would fade in after being included. They now snap in.

Chases with zero speed start running on Go: A chase with zero speed would start running when Go was pressed. A chase with zero speed now stays paused.

Copy Playback now copies all Playback options: The software now copies all playback options when copying the playback. Previously some would be ignored.

Certain Chases wont Unfold: In very rare circumstances it was possible for a chase to get in a state where it would not unfold. This has now been fixed.

Flip Pan and Tilt in Blind: The flip pan and tilt function does not work when in blind mode. This is now resolved.

Release on clear not releasing to playback levels: When releasing the programmer to playback levels it does not release correctly.

Stop on final step for backwards chase: When a chase was set to run in the backwards direction, the stop on final step setting would have no effect. It now stops on the first step before looping.

Picture Legends in other Languages: Picture legends may not display correctly when the console language is set to something other than English.

Deleting in channel grid does not remove fixture: When you have deleted all channels from a fixture using channel grid the fixture should be removed from the programmer.

DMX will not output on channel 512: It was not possible to output DMX on channel 512.

Workspace shortcuts in Record Menu: Workspace shortcuts would not work when in the record menu.

Workspace Legend Lost After Update: When you edit a workspace shortcut it lost the legend after the update.

Pressing [Off] Twice: Pressing the off key twice would open a strange off menu

Clear LED Locks On: The clear LED would stay on and not clear if you deleted a fixture while it was selected.

16.1.6 Bugs fixed in v.4.1

Fixed minor memory leak in chase view on touch consoles.: A memory leak would occur if you had the chase view open on touch consoles with a running chase. The memory would be freed if you disconnected the chase but may have caused problems if you left the console with a chase running for more than a few days.

Slow running with both Channel Grid and DMX view open: The operation of the console could slow down if you had both the DMX view and the channel grid open at the same time. This only occurred if the views contained channels that are changing.

Console freezing while clearing shapes from the programmer: Very occasionally the software may freeze while clearing shapes from the programmer.

Fader controls shape size and speed not working in Cue Lists: The option to control the shape size and speed was not working with cue lists.

Playbacks firing through Timecode at the same time as user operations: The software could freeze if a timecode playback was fired at the same time as the user firing playbacks.

Slow and silent memory leak: A memory leak which caused the console to display an out of memory exception after prolonged periods of use greater than 2 days has been fixed.

Copyright Avolites 2011

17. Glossary of terms

ADDRESSES	The DMX Channels occupied by individual Fixtures. The first Channel occupied is usually encoded onto the Fixture somehow (often by switches or using a menu) and called its ADDRESS.
ALIGN	A means of copying Attribute characteristics from the first Fixture selected to other selected Fixtures, resulting in the Fixtures being aligned to each other.
ATTRIBUTE	One Channel or function of an Intelligent Fixture, such as "Colour Wheel".
ATTRIBUTE GROUPS	see IPCGBES.
AUTOLOAD	A playback which is automatically fired by a cue in a cue list. Enables a chase to be fired by a cue list.
BACKUPS	Copies of a show stored to an external storage device for safety.
BPM	Beats Per Minute. 60BPM is equivalent to one step per second.
BUSKING	Operating the console live (usually for live music) when you have insufficient programming and need to make up stunning effects as you go along using palettes etc.
CHASE	A sequence of one or more pre recorded steps which automatically run one after the other.
CHASE STEPS	Individual cues within a Chase. See above
COLOUR CHANGER	A mechanical Fixture for changing the colour of a light source, usually by scrolling through a roll of different coloured gels or by moving special filters into the light beam.
COLOUR MIX / CMY	A system of three filters that can each crossfade from white to a colour, or one colour to another. It is a feature of some Intelligent Fixtures, which enables thousands of different colours to be created.
CONNECTED CHASE	A Chase which has been brought under control of a chase Controller by pressing the CONNECT button.
CUE	A single stage look programmed onto a Playback button or fader. Also known as MEMORY, STATE, SCENE, LOOK.
CUE LIST	A sequence of cues programmed onto a Playback button or fader. Each cue can have its own delay and fade times and can also start other cues or playbacks. Also known as a CUE STACK or STACK.
CUE MODE	A playback format programmed into a Cue. There are Cue Modes 0 - 3.
DEVICE	See FIXTURE.

DIMMER	Device used to control the intensity of an individual light.
DMX	DMX512(1990) a specification for communication between control desks and Fixtures, Originally for Dimmers it has been adopted as a control protocol for most Intelligent Fixtures. It can carry 512 different Channels of data.
FADE	A continuous transition from one level to another.
FIXTURE	Any lighting instrument that is patched using a Personality. Generally refers to a moving light or colour changer, not an individual Dimmer channel. Also called Intelligent Fixture, Device, Instrument, Moving Light.
FLASH	Pushbutton which adds a playback into the existing output of the console. Historically called the ADD button. See also SWOP.
FLIP	A function for use with Moving Head Fixtures. They have two possible Pan and Tilt positions for each point on stage, and FLIP will alternate between them.
FOCUS	What Palettes are called on other Avolites consoles. See PALETTE. May also be used in connection with moving fixtures to focus (set the sharpness) of a gobo projection.
FUNCTION WHEEL	A wheel which does not directly control an Attribute channel on a fixture, rather it controls only part of an attribute and another function wheel may control other parts. For example a rotating gobo attribute may have one function wheel to control continuous or indexed mode, and another function wheel to control rotation speed or position, though the actual fixture only uses one DMX channel to control both these functions.
GENERIC	Term used to indicate a Dimmer channel. See also FIXTURE.
GROUP	A GROUP is a pre-programmed collection of Fixtures that can be selected with a single button press.
HTP	Highest Takes Precedence, a mechanism for determining the output level of a channel being controlled by more than one Playback. The Playback outputting the Highest value at any given time will determine the level of the channel. Also see LTP.
HUD	Heads-up-display, an information window shown on the screen.
INCLUDE	A means of transferring the contents of a Cue or Chase Step into the Programmer.
INSTRUMENT	See FIXTURE.
INTELLIGENT FIXTURE	See FIXTURE.
IPCBES	The Attribute Groups, used by the console to conveniently group together similar attributes. For

	example the P(osition) group includes Pan and Tilt attributes.
LED	Refers to the small lights within the buttons on the console (stands for Light Emitting Diode).
LINKS	Connections between cues in a Cue List or Chase enabling them to run on from one to another automatically.
LOCATE	A feature of the console that makes it easy to find your selected Fixtures by putting them in Open White. Pressing Shift+Locate additionally sets the Pan and Tilt at 50%.
LTP	Latest Takes Precedence, a mechanism for passing control of a channel from one Playback to another on the basis that the latest Playback Fader to be moved has control, providing that Playback Fader has moved past the Trigger point. (See TRIGGER POINT). Also see HTP.
MACROS	Macros allow functions programmed into an Intelligent Fixture by the manufacturer to be executed by sending a DMX command sequence from the console. They can allow you to reset the Fixture for example. The DMX command sequences are defined within the Personality File. Also used in Titan to refer to a stored sequence of button presses.
MEMORY	The name for a Cue on other Avolites consoles.
MIDI	Stands for Musical Instrument Digital Interface. It is the established hardware and software specification enabling the exchange of data between digital musical instruments (such as keyboards) and other devices such as computers, sequencers and sound and lighting consoles.
MENU LATCH	Provides functions for control of Moving Lights (Moving Light Menu).
ON and OFF	Any channel stored in a playback can be On or Off. A channel which is ON is changed by the playback when it is fired. A channel which is OFF is stored in the playback for future re-use but has no effect when the playback is fired.
OVERLAP	Sets how the console allocates new values to a group of fixtures. 100% means that all fixtures are updated simultaneously. 0% means that the fixtures will be updated one after the other.
PALETTE	A term used to describe a referenced pre-defined state for an Attribute that can be recalled whenever required during programming. Each Fixture may be set to a different value in the Palette, the entries can be named, and recalled with a single button press.
PARK	A Parked fixture is one which is patched to a handle but has no DMX address set. This happens to a fixture when its DMX address is taken by another fixture during a later patching session; the Repatch function is used to give it a new DMX address.

PERSONALITY	A description of what Attributes a particular Intelligent Fixture has and how the console will patch and use these. It also determines which Attribute Wheel will control which Attribute.
PLAYBACK	Area of the console that can replay recorded Cues or Chases using Playback Faders.
PRELOAD	A playback button which sets the LTP channels in a cue but not the HTP channels. Used to pre-position fixtures before firing a cue. Also a cue list function which allows one cue to preload the LTP channels in another cue.
PRESET FOCUS	What Palettes are called on other Avolites consoles. See PALETTE.
PROGRAMMER	The part of the console which contains Channel information which has been changed by the user, prior to recording.
SAFE	Desk mode in which all Playback functions are enabled, but all programming functions disabled.
SELECTED	A Fixture that is under manual control.
SEQUENCE	See CHASE.
SHAPE	A preprogrammed effect available which is applied to an Attribute. It can then be customised and stored in a Cue.
SHARED PALETTE	A Palette in which information is only stored for one Fixture, but is available to all Fixtures of that type.
SOFTKEY	Buttons marked A-J, with different functions which are shown on the LCD screen above.
STACK	See CUE LIST.
SWOP	Type of flash button which turns on the output being flashed and turns off all other output while the button is pressed. Sometimes called "Solo". Also used for selecting fixtures or playbacks when programming. See also FLASH.
TABLE	List of pre-defined levels for an attribute allowing settings to be recalled by name (for example the colours available from a colour wheel may be found in a table).
TIMECODE	An electronic timer signal which allows cue list playback to be synchronised to a soundtrack or other events. The console can read MIDI timecode or can take a timecode from the Windows sound player application "Winamp". An internal free-running timer is also provided.
TRACKING	A mode in which Moving Lights can move around an area all pointing at the same spot.
TRAINING	The process of recording points on a stage so that the console can work out the TRACKING for Moving Lights.

TRIGGER POINT	The level set in the User Settings which determines at which point a Playback Fader triggers the LTP Channels programmed onto it.
UNFOLD	A function that allows Chase Steps to be laid out onto Playback Faders for easy editing.
USER SETTINGS	User definable desk settings. To change them, hold down the Avo button and select [User Settings].
VIRTUAL DIMMER	Used with LED RGB (red-green-blue) colour mixing fixtures, these add an intensity function to the fixture which masters the RGB controls on the fixture when it does not actually have an intensity control channel.
WIPEALL	A process which clears all the previous programming out of the desk, but does not touch the System Software.
WHEEL	Wheels are used on the console to set Fixture Attributes and to control chases and cue lists (see FUNCTION WHEEL).

Copyright Avolites 2011

Index

Softkey Menu items are indicated with capital letters (for example "Activate A Timecode Cuelist")

A

acceleration mode of wheels · 49
 ACDI, connecting up · 176
 active fixture
 media thumbnail · 50
 active fixtures · 178
 Add Swop button · 143
 Align fixtures · 58
 All button · 57
 always merge · 109
 Append · 123
 Append Cue (cue list) · 130
 Apply Time To Palette · 144
 ArtNet, setting up · 174
 As In · 137
 attribute editor window · 49
 attribute groups · 54
 attributes
 controlling · 48
 entering numerically · 51
 setting · 48
 auto connect chase · 161
 auto groups · 36, 55
 autoloading playback in cue list · 131
 autosave options · 31

B

backing up show · 31
 banks of attributes buttons · 48
 Blind mode · 107
 block shape · 75
 Bunch Up · 42, 72, 113
 busking · 144

C

channel button · 52
 channel grid window · 62
 chases
 appending new cues · 123
 connecting · 121
 cue linking · 127
 cue, fixture and attribute overlap · 126
 deleting · 113
 difference between chase and cue list · 129
 direction · 122
 editing using unfold function · 123
 global timing · 124
 individual cue times · 126
 inserting cues · 123
 pausing · 122
 recording · 119
 running · 120
 speed and crossfade · 121
 tap tempo · 125

 temporary speed · 121
 CITP · 178
 clear button · 47
 Clear button · 105
 clearing the console · 31
 colour picker · 49, 50
 compatibility view · 156
 connect button · 121
 copy chase · 124, 136
 copy cue · 112
 copy palette · 72
 copying
 fixtures · 42
 crossfade of chase · 121
 cue list
 append cue · 130
 attribute fade times · 138
 autoloading · 131
 cue legends · 131
 default delay/fade times · 130
 difference between chase and cue list · 129
 editing cues and times · 134
 killing · 133
 macro link · 132
 recording · 130
 setting times · 136
 update · 134
 Cue Overlap · 126, 138
 cue view · 110
 cues
 attribute fade times · 116, 127
 changing page · 108
 deleting · 113
 editing · 109
 fade modes · 115
 flashing · 107
 include function · 111
 playing back · 107
 recording · 106
 removing attributes · 111
 setting fade times · 113
 setting legends · 106
 curve · 117
 curves · 163
 curves, fan · 59

D

Delay Time · 115
 delete palette · 72
 deleting
 chase · 113
 cue · 113
 deleting patched fixtures · 42
 DHCP · 181
 dimmer, virtual · 49
 dimmers
 entering numerically · 52
 patching · 34
 display setup · 162
 DMX address
 displaying for fixture · 34
 setting for fixture · 35

DMX output mapping · 162
 DMX outputs · 20
 DMX triggering · 145
 DMX workspace window · 39

E

Edit Times · 113
 editing a cue · 109
 editing values · 62
 Editor · 105
 effects generator · 75
 enter numeric values · 51

F

fade curves · 163
 Fade Out Time · 115
 Fade Time · 115
 fade times for cues · 113
 fading palettes · 73
 fading palettes over time · 144
 Fan button · 58
 Fan curves · 59
 filtered palettes · 70
 firing a chase · 120
 fixture exchange · 40
 fixture layout · 56
 fixture macros · 63
 fixture order · 115, 139
 fixture order in a shape · 81
 Fixture Overlap · 115
 Fixture Overlap (chases) · 125, 139
 Fixture Overlap (cue lists) · 139
 fixture overlap (palettes) · 144
 fixture overlap with palettes · 73
 fixture page buttons · 33
 fixture personalities, downloading
 and installing · 169
 fixture select buttons · 33
 fixtures
 changing page · 46
 groups · 54
 locating · 46
 patching · 35
 selecting · 45
 step through selection · 57
 Flash Full/Flash Out · 57
 Flip · 58
 freeze fixture or attribute · 44

G

Generic fixtures · 170
 global chase timing · 124
 go and stop · 122
 Go button · 132
 group
 fixture layout · 56
 Group button · 54
 grouping fixtures · 54

H

handle paging · 117, 141, 142

HiLight button · 57
 HTP and LTP, explanation of · 107

I

Include button · 111
 Insert (in unfold mode) · 134
 Insert (rec chase) · 123
 insert chase step · 123
 Invert attributes · 43
 IP address, setting · 173
 IP addressing explained · 179
 IPCGBES groups · 54
 iPod/iPhone · 149

J

jump to step in chase · 122

K

key profile
 individual for playback · 118, 142
 key profiles · 157
 keyboard not working · 28
 keyboard shortcuts · 27

L

latch menu · 24
 latching the copy menu · 113
 latching the rec cue menu · 106
 LED brightness · 161
 legend button · 68
 legend, pictures · 68
 legends
 setting for fixtures/dimmers · 38
 legends for cues in cue list · 131
 level matching of playbacks · 108
 Link (cue lists) · 137
 Link Offset · 137
 Load Show · 30
 loading a show · 30
 Locate button · 46
 lock playback on handle · 117, 141,
 142
 lock the console · 29
 LTP and HTP, explanation of · 107

M

macro in cue list · 132
 macro, link to cue · 142
 macros · 63
 macros (keypress) · 27
 mask
 clear · 47
 mask, toggle groups · 67
 master overlap (palette) · 73
 master palette overlap · 73
 master palette time · 73
 master time (palette) · 73
 media servers, setting up · 178

MIDI timecode options · 161
 MIDI triggering · 145
 mode 0 - 3 for cues · 115
 move chase · 124, 136
 move cue · 112
 move function · 145
 move palette · 72
 Moving fixture · 41
 Multi-DMX fixture · 170

N

New Show · 31

O

Off button · 111
 order of fixtures · 115

P

page
 selecting fixture pages · 33
 page buttons · 70
 page legends · 38, 108
 pages of cues · 108
 pages of fixtures · 46
 pages of palettes · 70
 pages show/hide button · 33
 Palette Bank buttons · 70
 palette fade button · 74
 palettes · 65
 creating · 66
 editing and deleting · 71
 fading over time · 73, 144
 fixture overlap · 144
 master overlap · 73
 master time · 73
 recalling · 69
 setting legends · 68
 update · 71, 109
 viewing values · 70
 park fixture · 38
 patching
 copying fixtures · 42
 deleting fixtures · 42
 dimmers · 34
 displaying DMX view window · 34
 edit personality · 44
 fixtures · 35
 freezing attributes · 44
 inverting attributes · 43
 setting legends · 38
 sub fixtures · 37
 swap pan and tilt · 43
 pattern selection · 53
 pausing a chase · 122
 pearl expert shows · 156
 personality, editing · 44
 phase of shapes · 79
 phase offset · 79
 picture legend · 68
 picture legends · 23
 pixel mapper · 79
 pixel mapper examples · 83
 pixel mapper preview · 80
 playback options
 chases · 127
 cues · 117

playback priority · 117
 playback view · 110
 playbacks
 releasing · 108
 preset palettes · 36
 Press to show DMX channels · 34
 Prev/Next buttons · 57
 priority setting for playback · 117
 Programmer · 105
 prompt for merge · 160

Q

Quick build · 120
 quick build cue · 106
 quick palettes · 70
 quick record · 23
 palette · 68

R

Rec Step button · 134
 Rec Times button · 134
 Record (in unfold mode) · 123, 134
 Record Chase button · 119
 Record Cue button · 106
 recording macros · 27
 release mask · 117
 releasing playbacks · 108
 Rem Dim · 58
 remote control · 149
 remote trigger · 145
 remove fixtures from a shape · 82
 resetting fixtures · 63
 Retain Layout · 42, 72, 113
 running a chase · 120

S

Save Show · 30
 saving show to hard disk · 30, 31
 Select a DMX line · 35
 Select Cue · 136
 Select Fix Page button · 46
 select if · 54
 selecting a range of fixtures · 45
 selecting fixtures in a pattern · 53
 Set Cue Times (in unfold mode) · 124
 Set Fixture Order · 139
 Set IPCGBES Times · 116, 127
 Set Legend button · 38, 106
 Set Out Time · 137
 setting attributes · 48
 Setup button · 30, 31
 shape generator · 75
 shape speed and size · 78
 shapes
 deleting · 82
 editing shape in a cue · 81
 fading in · 82, 117
 fixture order · 81
 phase · 79
 reversing · 82
 shapes window · 76
 shortcut keys · 27
 show file
 saving and loading · 30

simulator · 29
Snap Back button (cue lists) · 133
software, upgrading · 167
Speed (chase) · 125
speed of chase · 121
spread of shapes · 79
Stop button (cue lists) · 133
Store Palette · 66
sub fixtures · 37
swap items if required · 42, 72, 113
Swap Pan Tilt · 43
system menu · 160

T

tap tempo · 125
tempo units · 160
temporaru speed · 121
temporary chase speed · 160
text size · 161
theatre mode · 129
timecode · 140
Titan simulator · 29
toggle mask · 67
touch button size · 161
transparent lock · 117, 141

U

undo/redo · 27
unfold
 cue list · 133
Unfold button · 123
Unknown fixtures · 170
unlinking chase cues · 126
update · 71, 109, 134

update personalities · 41
upgrading the software · 167
user number · 34
user settings menu · 160

V

view DMX output · 39
view fixture patch · 38
view menu · 145
viewing key profiles · 157
virtual dimmer · 49
Visualiser · 26
Visualiser auto patch · 37

W

warn before parking fixtures · 160
Wheel sensitivity · 161
wheels
 acceleration · 49
 controlling attributes · 48
 fast mode · 49
window positions · 22, 155
Wipe · 161
wipeall · 31
workspace
 positioning windows · 22, 155
 saving · 23, 155
 window options · 22

X

X in fixture order · 116

Avolites Titan Operator's Manual (Titan Mobile version)

part number **8200-0170**

Price £30

Additional copies of this manual, together with other useful spares etc. can be purchased through the Avolites On line shop. Visit <http://www.avolites.com> then navigate to Avo Shop from the links on the left hand side.